

Village of Hampshire
Village Board Meeting
Thursday July 2, 2015 – 7:00 PM
Hampshire Village Hall – 234 S. State Street

AGENDA

1. Call to Order
2. Establish Quorum (Physical and Electronic)
3. Pledge of Allegiance
4. Citizen Comments
5. Approval of Minutes – June 18, 2015
6. Village President's Report
 - a) Raffle License – Hampshire V.F.W. – July 30- Aug 1, 2015
7. Village Board Committee Reports
 - a) Economic Development
 - b) Finance
 1. Accounts Payable
 - c) Planning/Zoning
 - d) Public Safety
 - 1) Adopt a Hydrant
 - e) Public Works
 - f) Village Services
 - g) Fields & Trails
- 8) New Business
 - 1) Farmers Market discussion (Trustee Reid)
- 9) Announcements
- 10) Executive Session:
Probable, Pending or Imminent Litigation 2 C (11) and 2 C (1) Personnel appointment, employment, compensation, discipline, performance or dismissal of a specific employee.
- 11) Any items to be reported and acted upon by the Village Board after returning to open session
- 12) Adjournment

The Village of Hampshire, in compliance with the Americans With Disabilities Act, requests that persons with disabilities, who require certain accommodations to allow them to observe and/or participate in the meeting(s) or have questions about the accessibility of the meeting(s) or facilities, contact the Village at 847-683-2181 to allow the Village to make reasonable accommodations for these persons

VILLAGE OF HAMPSHIRE - BOARD OF TRUSTEES

Meeting Minutes – June 18, 2015

The regular meeting of the Village Board of Hampshire was called to order by Village President Jeffrey Magnussen at 7:01 p.m. in the Village of Hampshire Village Board Room, 234 S. State Street, on Thursday June 18, 2015.

Present: George Brust, Marty Ebert, Toby Koth, Jan Kraus, Mike Reid.

Absent: None

Trustee Ebert moved, to authorize Trustee Whaley present via telephonic connection.

Seconded by Trustee Reid
Motion carried by voice vote
Ayes: All
Nays: None
Absent: None

Staff & Consultants present: Village Finance Director Lori Lyons, Village Attorney Mark Schuster, and Hampshire Police Chief Brian Thompson.

A quorum was established.

The Pledge of Allegiance was said.

CITIZEN COMMENTS

Orris Ruth- asked when there will be a Field & Trails meeting, Trustee Koth responded as soon as his committee can agree to a date to meet, also there will be a 2-year sunset clause regarding how this will be funded, concept plan and design plan.

Nancy Liss – inquired about the ten dollar fee on the water bills, Village President Magnussen explained it's for sewer/infrastructure and is ongoing cost. Then asked the tax rate why so high when Hampshire has nothing to offer. Village President Magnussen did mention a few years ago the market for homes hurt the Village and now it's just starting to pick up. The Village understands her frustration but it all will take time, we are looking for feedback from residents like you so all comments are welcomed.

Dell Koseyla- he lives on Prairieview Pkwy and understands the stop sign and has been notified by Trustee Brust and police officers to move his trailer. All he is asking for is to let him park the trailer across the street just for two hours either to unload or load up and leave. The island down the road from him he was inquiring if the street department will be trimming and weeding instead of a little old lady doing that on her own.

Trustee Brust moved, to approve the minutes of June 4, 2015.

Seconded by Trustee Kraus
Motion carried by voice vote
Ayes: All
Nays: None
Absent: Whaley

VILLAGE PRESIDENT REPORT

Request to close a portion of Ridgecrest Drive from stop sign to stop sign on July 3, 2015 from 12:00 PM – 10:00 PM for a Neighborhood Block Party

Trustee Brust moved, to approve the request to close a portion of Ridgecrest Drive from stop sign to stop sign on July 3, 2015 from 12:00 PM – 10:00 PM for a Neighborhood Block Party

Seconded by Trustee Kraus
Motion carried by voice vote
Ayes: All
Nays: None
Absent: Whaley

Resolution – Must obtain a written permit from the Illinois Department of Transportation to do any work on the state right of way

Trustee Brust moved, to approve Resolution 15-12: Must obtain a written permit from the Illinois Department of Transportation to do any work on the state right of way.

Seconded by Trustee Ebert
Motion carried by roll call vote
Ayes: Brust, Ebert, Koth, Kraus, Reid
Nays: None
Absent: Whaley

Ordinance- Establishing certain places for No Parking in the Village. (Northerly and easterly side of White Oak from Jake to Jefferson and Northside of Jefferson Ave. from Stoneshire Ct. to Warner).

Village President Magnussen would like to table this until the next board meeting, we need to let the public know ahead of time before passing the ordinance.

Trustee Brust moved, to table ordinance establishing certain places for No Parking in the Village. (Northerly and easterly side of White Oak from Jake to Jefferson and Northside of Jefferson Ave. from Stoneshire Ct. to Warner).

Seconded by Trustee Kraus
Motion carried by voice vote
Ayes: All
Nays: None
Absent: Whaley

Ordinance – Amending the Police Regulations to add certain regulations governing parking of certain vehicles in residential zoning districts in the Village.

Trustee Reid moved, to approve Ordinance 15-20; amending the Police Regulations to add certain regulations governing parking of certain vehicles in residential zoning districts in the Village, with the changes as directed.

Seconded by Trustee Ebert
Motion carried by roll call vote
Ayes: Brust, Ebert, Koth, Kraus, Reid
Nays: None
Absent: Whaley

Well No. 9 Rehabilitation Project - reconsideration of bids

Trustee Koth moved, to reconsider the action taken by the Board at its meeting of June 4, 2015, rejecting all bids for the Well #9 rehabilitation project.

Seconded by Trustee Ebert
Motion carried by voice vote
Ayes: All
Nays: None
Absent: Whaley

Trustee Ebert moved, to accept the base bid of Layne Christensen Company in the total amount of \$130,006.00 for the Well # 9 Rehabilitation Project.

Seconded by Trustee Brust
Motion carried by roll call vote
Ayes: Brust, Ebert, Koth, Kraus, Reid
Nays: None
Absent: Whaley

Resolution: establishing a purchasing policy for the Village of Hampshire

Trustee Reid moved, to approve establishing a purchasing policy for the Village of Hampshire.

Seconded by Trustee Koth
Motion carried by roll call vote
Ayes: Brust, Ebert, Koth, Kraus, Reid
Nays: None
Absent: Whaley

Police Department Windows Server -2003

Trustee Reid moved, to approve to purchase software and hardware and secure the services of Entre to replace the server and operating system at the Police Department at a cost of \$10,573.74.

Seconded by Trustee Brust
Motion carried by roll call vote
Ayes: Brust, Ebert, Koth, Kraus, Reid
Nays: None
Absent: Whaley

Supplemental Insurance

Trustee Kraus moved, the Board authorize initiation of supplemental insurance offerings through AFLAC with the start date of July 1 (first deduction will be made July 23, 2015.)

Seconded by Trustee Koth
Motion carried by roll call vote
Ayes: Brust, Ebert, Koth, Kraus, Reid
Nays: None
Absent: Whaley

Uniform Update

Trustee Brust moved, to allow Public Works Department employees to wear shorts under the guidelines.

Seconded by Trustee Ebert
Motion carried by roll call vote
Ayes: Brust, Ebert, Reid
Nays: Koth, Kraus
Absent: Whaley

VILLAGE BOARD COMMITTEE REPORTS

Economic Development

Trustee Brust reported the car show was a big hit at the street dance, ribbon cutting at the T.A. and Country Pride Restaurant had a good turnout. Metrowest will be hosting legislative from Washington and will be held at E.C.C. on August 27. The Cemetery Walk was very interesting and went back to 150 years with people dressing up in that era.

Trustee Brust reported an Economic Development meeting will be held on July 10, 2015 at the Village Hall.

b. Finance

Accounts Payables

Trustee Kraus moved, to approve accounts payable in the amount of \$185,885.82 to be paid on or before June 23, 2015.

Seconded by Trustee Ebert
Motion carried by roll call vote
Ayes: Brust, Ebert, Koth Kraus, Reid
Nays: None
Absent: Whaley

c. Planning/Zoning

No report

Public Safety

Trustee Reid wanted to thank everyone who helped out with putting together the Trailer Ordinance.

e. Public Works

No report

f. Village Services

No report

g. Field & Trails

Trustee Koth reported he will be having a Fields & Trails meeting soon, with a 2- year sunset clause for designing, funding and concept plan.

Executive Session

Trustee Brust moved, to adjourn to executive session to discuss Personnel- appointment, employment, compensation, discipline, performance or dismissal of a specific employee under Section 2 (c) 1 and Probable, Pending or Imminent Litigation under Section 2(c) (11) Open Meetings Act, at 8:09 p.m.

Seconded by Trustee Kraus
Motion carried by roll call vote
Ayes: Brust, Ebert, Koth Kraus, Reid
Nays: None
Absent: Whaley

The Village Board reconvened at 8:23 PM

Trustee Ebert moved, to have Attorney Schuster draft a letter to request reimbursement of wages when the time is right to send it out.

Seconded by Trustee Koth
Motion carried by roll call vote
Ayes: Brust, Ebert, Koth Kraus, Reid
Nays: None
Absent: Whaley

Village President Magnussen announced Happy Father's Day.

Adjournment

Trustee Brust moved, to adjourn the Village Board meeting at 8:25 p.m.

Seconded by Trustee Ebert
Motion carried by voice vote
Ayes: All
Nays: None
Absent: Whaley

Linda Vasquez, Village Clerk

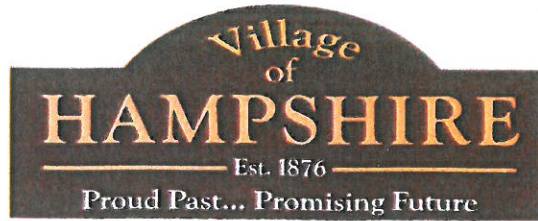

234 S. State Street
Hampshire, IL 60140

Phone: (847) 683-2181
Fax: (847) 683-4915
www.hampshireil.org

APPLICATION FOR CONDUCTING A RAFFLE
(GOOD FOR ONE RAFFLE)

Name of Organization: HAMPSHIRE V.F.W. Post 8043

Address: P.O. Box ~~317~~ Hampshire, IL 60140

Type of Organization: Religious 416 Charitable _____ Veterans Educational _____ Labor _____ Fraternal _____

Date when this group was organized: 1946

If chartered or incorporated, date and place where papers were issued: _____

HAMPSHIRE JULY 1946

Date when raffle winners will be determined: SEPT. 6, 2015

Time: 4:00 P.M. Location: BURLINGTON PARK

Area or Areas where tickets will be sold: BRUCE REAM PARK

Date of ticket sales: JULY 30TH 2015 to AUG 2, 2015

Price of each ticket: \$1.00 EA. OR. 6 FOR \$5.00

Prizes to be awarded and retail value of each, (May be listed on separate sheet)

No.	Prize	Value of each	Total Value
<u>1</u>	<u>\$500.00</u>	<u>\$500.00</u>	<u>\$500.00</u>
<u>2</u>	<u>\$100.00</u>	<u>\$100.00</u>	<u>\$200.00</u>
<u>3</u>			

TOTAL AGGREGATE VALUE OF ALL PRIZES \$700.00

Presiding Officer: Jimmy Cagle

Address: 2637 Wedgemere Dr. Huntley, Ill 60142

Phone: 773-758-8625 Date of Birth: ?

Secretary: Jody Renabel

Address: 510 Fox Run Ln. Hampshire, Ill 60140

Phone: 847-533-1941 Date of Birth: ?

Raffle Manager: Lowell REISER

Address: 13N 230 BRIER Hill Rd HAMPSHIRE, Ill 60140

Phone: 847-683-3243 Date of Birth: 3-6-31

I certify that this organization is not-for-profit; it has been in existence continuously for at least the past five years; it has maintained a bona fide membership engaged in carrying out its objectives; its officers, operators, and workers at the raffle are bona fide members of the organization and are of good moral character. I further certify that all of the information provided in this application is true, to the best of my knowledge.

Signed: Lowell Reiser

Title: Trustee

Fee Schedule:	
Aggregate Value	Fee:
Less than \$500	None
\$501-\$5,000	\$10.00
\$5,001 and over	\$25.00

***Each licensee, within thirty (30) days of the raffle, shall report to its membership and to the village clerk each of the following:

- a. Gross receipts generated by the conducting of the raffle;
- b. An itemized list of all reasonable operating expenses which have been deducted from the gross receipts;
- c. Net proceeds from the conducting of the raffle;
- d. An itemized list of the distribution of the net proceeds; and
- e. A list of prize winners.

Records required by this section shall be preserved for three (3) years, and the organization shall make available for public inspection their records relating to the operation of a raffle at reasonable times and places.

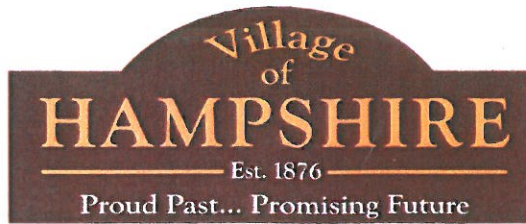

234 S. State Street
Hampshire, IL 60140

Phone: (847) 683-2181
Fax: (847) 683-4915
www.hampshireil.org

OFFICIAL BOND FOR RAFFLE MANAGER

(To be used when aggregate value of prizes is less than \$15,000)

KNOW ALL MEN BY THESE PRESENTS THAT WE, Lowell Reiser
Raffle Manager
and J.L. Jones Ins. Agency - Huntley, Ill
Surety

Are held and bound to: HAMPSHIRE V.F.W. Post 8043
Name of Organization

In the sum of \$ _____, equal to aggregate retail value of all prizes, for the payment of such we are obliged.

The condition of the above obligation is such that Lowell REISER
Being of legal age, has been appointed Raffle Manager for a raffle to be conducted on 9/6, 2015.
Month/day Year

NOW, THEREFORE, if the said Raffle Manager shall perform and discharge all the duties required of him/her as raffle manager, then this Bond is to be void; otherwise to remain in full force.

Raffle Manager's signature: Lowell Reiser
Address: 171230 Green Hill Dr. Huntley, Ill City: _____
60143

Surety's signature: _____
Address: _____ City: _____

I, Linda R Vasquez, a notary public in Illinois, certify that Lowell Reiser
and _____

Who are both personally known to me, are the same persons whose names are subscribed to above; that they appeared before me this day in person and acknowledged that they signed, sealed and delivered said instrument as their free and voluntary act, for the use and purpose therein set forth.

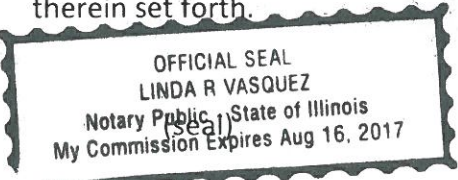

6-22-15
Date

Given under my hand and seal on this date.

[Signature]
Notary Public

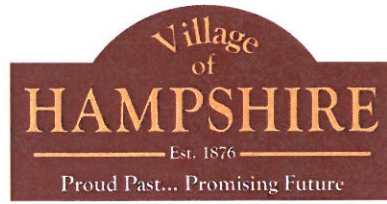

The Village of Hampshire & The Hampshire Fire Protection District Invite you to Adopt A Fire Hydrant

The Village of Hampshire, in collaboration with the Hampshire Fire Protection District, is pleased to announce the adopt a hydrant program. Interested artists (no residency requirements) will be permitted to “adopt” fire hydrants within the village limits of Hampshire and create artistic designs for them. This season fire hydrants throughout Hampshire will be available for artists to paint. The goal of this program is to embrace the artistic talents of local individuals while displaying creative artwork throughout the community. There is no specific theme for this program. However, artists are encouraged to incorporate the character of the surrounding environment and neighborhood into their artwork. The Village of Hampshire along with the Hampshire Fire Protection District will award first, second, and third place winners for the best hydrant designs. There is no cost to apply for the program.

PROGRAM DETAILS

How can I participate in this program?

- Fill out the application/design proposal (page 2 of this form)
- Fill out the waiver (page 3 of this form)
- Submit the required forms to the Village of Hampshire

How should I begin painting after receiving Village / Fire District approval?

- Remove all dirt, mud, and debris from the hydrant before painting
- Protect the immediate area around the hydrant from paint stains
- Use high quality, oil-based enamel paint for metal
- Painting will be allowed from May 1st through September 1st

What is prohibited on the hydrants?

- Inappropriate words, advertisements, political messages, etc.
- Glued or attached objects
- Camouflage or designs that significantly reduce hydrant visibility
- Please avoid using dark colors as they reduce hydrant visibility

Once I have finished painting my hydrant, what should I do?

- Participants will clear snow and debris away from the hydrant
- Participants of the program will be recognized on the master list at the Hampshire Fire Department
- Maintain your hydrant’s artistic design for up to one year



For questions about the Art on Fire Program, contact the Village of Hampshire at (847) 683-2181 or contact the Hampshire Fire Protection District at (847) 683-2629.

APPLICATION/DESIGN PROPOSAL

Name _____

Phone _____ Email _____

Mailing Address _____

Location of Preferred Hydrant _____

Please Describe Your Artistic Abilities and Experiences _____

Use the fire hydrant below to illustrate your proposed artistic design:

Front

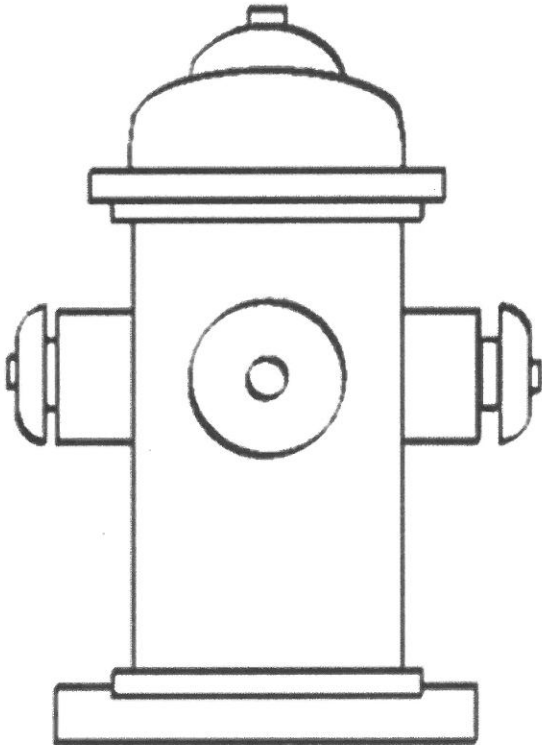

Back

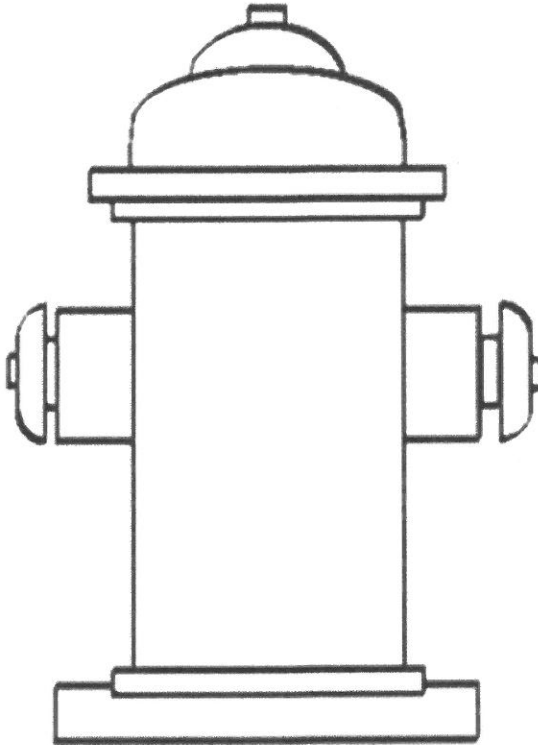

Title of your Artwork _____

Applicants must submit this page and the waiver (see page 3 of this application) via mail or in-person

Waiver, Hold Harmless and Indemnity Agreement

In consideration of the Village of Hampshire accepting me as a participant in this program, I understand and agree to the following:

A. Agreement/General Provisions

I understand and grant the Village of Hampshire, its successors, assigns, and licensees, the perpetual right to photograph, film, use and reproduce, as the village desires, photographs and videotapes taken of myself and/or my children during any activity of this program. I understand that I will not receive any compensation for my participation or my children's participation in the photographs and videotapes and that the Village of Hampshire shall own all right, title, and interest to the photographs and videotapes, including the portions that contain the images and voices of myself and/or children.

B. Waiver, Hold Harmless and Indemnity

I fully understand and agree to assume all risks of injury associated as a participant in this program for the Village of Hampshire.

I understand that the Village of Hampshire is not responsible for any loses, medical or otherwise, incurred arising out of participation in this program. I hereby waive any and all claims against the Village of Hampshire, its elected officials, employees, and/or agents for bodily injury or death arising out of, or in any manner connected with, participation in this program.

I will defend, indemnify, keep and hold harmless the Village of Hampshire, its elected officials, employees, and/or agents from all damages, judgments, expenses (including reasonable attorney fees) suffered because of the injury or the death of any person or persons, or because of damage to property that may arise out of, or as a consequence of my or my family's participation in this program.

I certify that I have read and understood the above agreement as the terms under which I will be allowed to participate in this program with the Village of Hampshire. This waiver, hold harmless and indemnity agreement form is effective following signature, unless revoked in writing.

Participant Information:

(Participant Name – Please Print)

(Phone)

(Street Address)

(City, State, Zip)

(Signature)

(Date)

Complete this form and return it with the application/design proposal

From the community: Geneva's 'Art On Fire' Hydrant Design Contest Returns This Spring

By **Community Contributor** City of Geneva

APRIL 1, 2015, 3:02 PM

Geneva residents can leave their artistic mark on our community this spring by participating in the "Art on Fire" hydrant design program.

The City of Geneva, in collaboration with the Cultural Arts Commission, is seeking artists to "adopt" and paint fire hydrants. More than 50 hydrants have been painted the past two years as part of "Art on Fire," and the program has been well received by residents and visitors who have taken notice of the artwork in the downtown and surrounding areas.

With more than 1,800 fire hydrants throughout Geneva, plenty of "blank canvas" remains for artists to submit new entries this spring. "Art on Fire" was established by Mayor Kevin Burns in 2013 as a way to showcase Geneva's artistic talent and bring art into the community.

"The 'Art on Fire' program continues to ignite imagination, creativity and community participation," Mayor Burns said. "I look forward to the new designs that will soon be displayed on fire hydrants across Geneva."

The program is free and open to the public, but participants need to submit an application to the City by Friday, May 1. The application can be found on the City's website at www.geneva.il.us or picked up at Geneva City Hall, 22 S. First St.

"Art on Fire" does not mandate a specific theme, but the program encourages artists to incorporate the character of the hydrant's surrounding environment into their design. City staff reviews and approves all application designs to make sure they do not compromise the visibility of the hydrants for firefighters in an emergency. Artists will be allowed to paint their hydrants during the month of May.

The City's Public Arts Advisory Committee and Cultural Arts Commission will again judge the hydrants and award prizes to the top three design winners in June.

People can take a virtual tour of all the decorated hydrants on an interactive map posted on the City's website. The map will be updated this summer to include all the 2015 submissions.

This item was posted by a community contributor. To read more about community contributors, [click here](#).

Copyright © 2015, Chicago Tribune

FROM AROUND THE WEB

Sponsored Links

IBM Serves Wimbledon Tennis with Data Analytics

IBM

Steve Forbes: Mutual Funds Cost You 60% Of Your Savings

Newsmax Finance

Tallulah Willis Opens Up About Her Body Image

Yahoo News With Katie Couric

Insanely Popular Sweatshirt Has 4 Month Wait List

Slate | American Giant Hoodie

Here's What's Leaving Netflix Forever In June

Refinery29

Top Foods to Avoid with High Blood Pressure

HealthCentral.com

4 Billionaires Say: Something Big Coming Soon In U.S.A

Stansberry Research

Top 11 Cities Of The Rich You Never Knew Existed

Forbes

by Taboola

Connecticut State Senator
Tony Hwang
Proudly Serving the 28th District

Home About Tony Newsroom District Resources Contact

search...

Sen. Hwang Joins Jeanne Harrison, Community Volunteers for Fairfield Fire Hydrant Painting Project

June 5, 2015

Like Tweet

2



Pat McDonald, a retired Fairfield teacher and longtime resident, and state Sen. Tony Hwang (R-28) help support Jeanne Harrison's community service project painting fire hydrants in town.

FAIRFIELD – A small army of volunteers, brandishing paint brushes and armed with an unshakable desire to give back to the community, have converged on streets around town with a single mission: to pay homage to Fairfield's revolutionary history through a creative and fun project.

The targets are fire hydrants that line Fairfield's streets and their leader is the indefatigable Jeanne Harrison. On a recent afternoon, Sen. Tony Hwang (R-28) joined Harrison and a small group of volunteers to engage in this ongoing effort, transforming the often unsightly and overlooked hydrants into tiny Red Coat soldiers that have excited children and adults alike.

Joining Harrison and Sen. Hwang were Adam Plotnick, of Turney Road, and Pat McDonald, a retired Fairfield teacher and longtime resident. The group chatted and laughed as they painted a hydrant at the I-95 rest stop in Fairfield and later, while doing some touch-ups to one near Jennings Beach, Harrison retraced the origins of her "labor of love."

As the town prepared to celebrate our country's bicentennial in 1976, Harrison approached

RELATED CONTENT

June 26, 2015

[Community Leaders Celebrate Opening of Renovated Pavilion at Sherwood Island State Park in Westport](#)

June 26, 2015

[Sen. Hwang to Deliver Keynote Speech at Fourth of July Ceremony in Fairfield](#)

June 5, 2015

[Senator Hwang to Host 2015 Legislative Recap](#)

Like Share

[Follow @senatorhwang](#) 282 followers

SIGN-UP FOR CAPITOL UPDATES

then First Selectman John J. Sullivan with her idea. Approvals were secured and Harrison was told she could start with a test – one hydrant.

Before she even finished that first hydrant, residents were calling the town asking how they could get the hydrant near their home painted, too.

The project quickly took on a life of its own and Harrison realized she was going to need help. She didn't have to look very far. Over the years, volunteers have come from Boy and Girl Scouts, Wakeman's Boys and Girls Club, and the Association of Retired Teachers of Fairfield.

Plotnick became involved when he asked Harrison if she would paint a hydrant near his house. "I'll do it if you help me," was her answer, Plotnick recalled. "I think they look great and I want to help Jeanne," he added, explaining his reasons for continuing to volunteer his time for the project.

"The love that people have for these hydrants, I never thought that would happen," said Harrison, who is now 83.

"This project truly represents all that is good about Fairfield and our residents," Sen. Hwang said. "It speaks volumes about Jeanne's character and the love she has for our community, and it also highlights the strong sense of volunteerism that the people of Fairfield have and the incredible appreciation we have for our town's rich and storied history."

Harping back to that history, some have asked Harrison why paint Red Coats and not the Patriots, given that the British burned nearly every home in town to the ground on their way to Danbury during the Revolutionary War.

"Now the British put the fires out," McDonald joked.

STATE SENATOR TONY HWANG

Legislative Office Building
Room 3400
Hartford, CT 06106
Phone: 1-800-842-1421



THE 28TH DISTRICT IS COMPRISED OF:
Easton, Fairfield, Newtown, Weston & Westport
[view on Google Maps >>](#)

ABOUT TONY

Biography [PDF]
Official Photo

NEWSROOM

In the News
Video
Photos
Audio

TAKE ACTION

Sign-Up for Capitol Updates
Legislative Schedule
Visit the Capitol

EXTERNAL LINKS

CT General Assembly
Senate Republicans
CT.gov

CONTACT

Email Tony

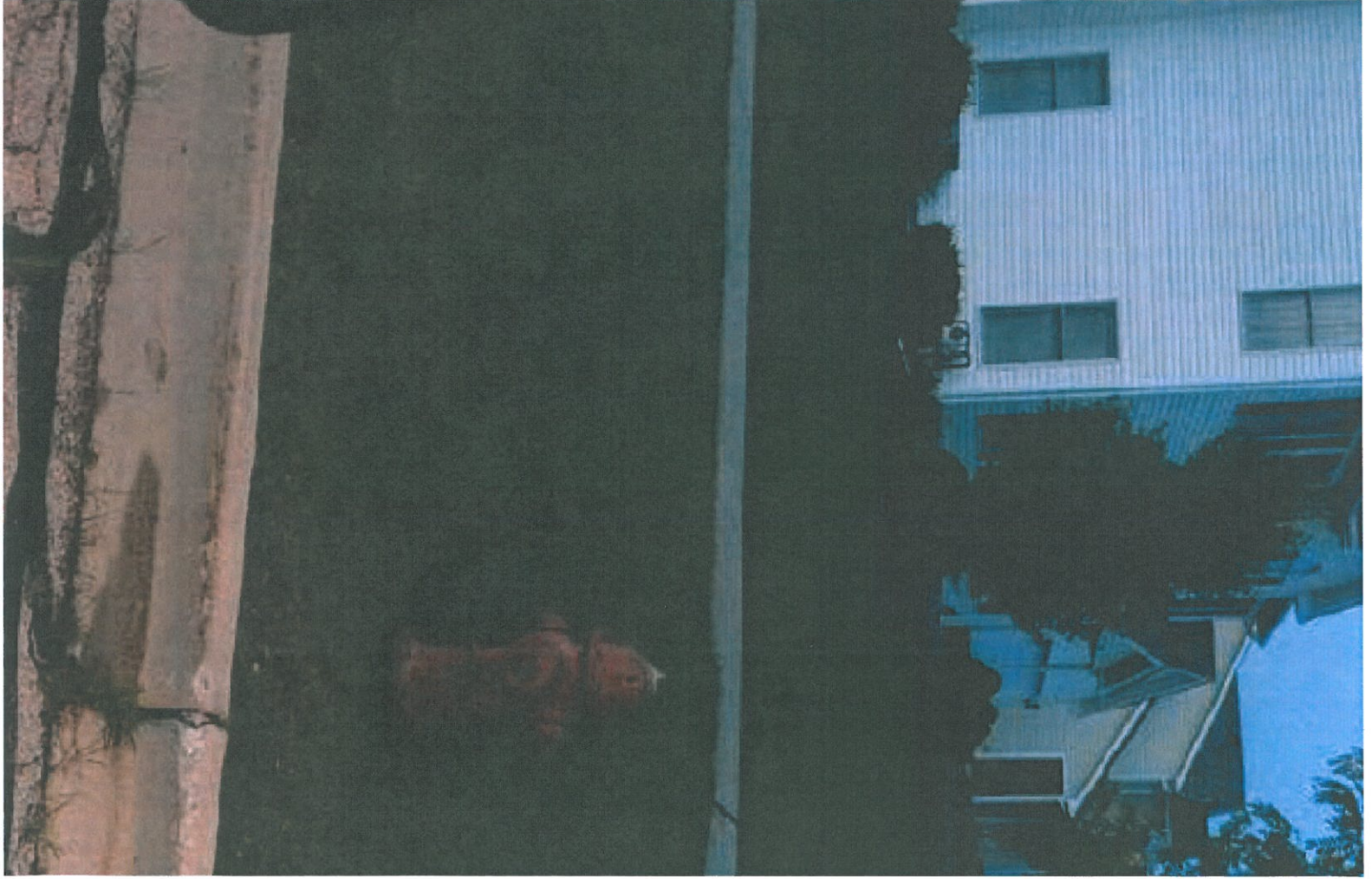





VILLAGE OF HAMPSHIRE

Accounts Payable

July 2, 2015

The President and Board of Trustees of the Village of Hampshire
Recommends the following Warrant in the amount of

Total: \$44,522.09

To be paid on or before
July 9, 2015

Village President: _____

Attest: _____

Village Clerk: _____

Date: _____

DATE: 06/30/15
 TIME: 08:18:00
 ID: AP441000.WOW

VILLAGE OF HAMPSHIRE
 DETAIL BOARD REPORT

INVOICES DUE ON/BEFORE 06/30/2015

INVOICE #	INVOICE DATE	INVOICE #	DESCRIPTION	ACCOUNT #	P.O. #	DUE DATE	ITEM AMT
APCO	APPLIED COONCEPTS, INC						
271783	06/25/15	01	INV#271783	01-002-005-4906 EQUIPMENT		06/25/15	1,369.00
						INVOICE TOTAL:	1,369.00
						VENDOR TOTAL:	1,369.00
CDW	CDW GOVERNMENT, INC.						
5346779	06/30/15	01	INV#5346779	01-002-005-4906 EQUIPMENT		06/30/15	955.64
						INVOICE TOTAL:	955.64
						VENDOR TOTAL:	955.64
CEFL	CENTURION FLEET SERVICES INC						
2190	06/25/15	01	INV#2190	30-001-002-4110 MAINT. VEHICLES		06/25/15	57.81
						INVOICE TOTAL:	57.81
						VENDOR TOTAL:	57.81
COED	COMMONWEALTH EDISON						
JULY 2015	06/26/15	01	ACCT#0255144168	30-001-002-4260 UTILITIES		06/26/15	419.19
		02	ACCT#2289551008	30-001-002-4260 UTILITIES			89.62
		03	ACCT#2599100000	30-001-002-4260 UTILITIES			5,155.52
		04	ACCT#6987002019	30-001-002-4260 UTILITIES			63.12
		05	ACCT#4997016005	30-001-002-4260 UTILITIES			129.79
		06	ACCT#9705026025	30-001-002-4260 UTILITIES			600.17
		07	ACCT#0729114032	30-001-002-4260 UTILITIES			98.12

INVOICES DUE ON/BEFORE 06/30/2015

INVOICE #	INVOICE DATE	ITEM #	DESCRIPTION	ACCOUNT #	P.O. #	DUE DATE	ITEM AMT
COED	COMMONWEALTH EDISON						
JULY 2015	06/26/15	08	ACCT#2323117051	30-001-002-4260		06/26/15	5.55
		09	ACCT#04951111058	UTILITIES			50.51
		10	ACCT#0710116073	UTILITIES			75.44
		11	ACCT#1939142034	31-001-002-4260			383.57
		12	ACCT#2676085011	UTILITIES			2,648.61
		13	ACCT#7101073024	UTILITIES			308.59
		14	ACCT#2244132001	01-003-002-4260			1,732.31
		15	ACCT#5175128047	STREET LIGHTING			1,177.69
		16	ACCT#3461028010	01-003-002-4260			59.25
		17	ACCT#2539042023	STREET LIGHTING			8.39
		18	ACCT#0524674020	01-003-002-4260			16.06
		19	ACCT#1329062027	STREET LIGHTING			10.69
		20	ACCT#4623084055	01-003-002-4260			3.54
							INVOICE TOTAL: 13,035.73
							VENDOR TOTAL: 13,035.73

CONEEN CONSTELLATION NEW ENERGY

0024972773	06/26/15	01	ACCT#1-BQIA09	30-001-002-4260		06/26/15	35.27
				UTILITIES			INVOICE TOTAL: 35.27

DATE: 06/30/15
 TIME: 08:18:00
 ID: AP441000.WOW

VILLAGE OF HAMPSHIRE
 DETAIL BOARD REPORT

INVOICES DUE ON/BEFORE 06/30/2015

INVOICE #	INVOICE DATE	ITEM #	DESCRIPTION	ACCOUNT #	P.O. #	DUE DATE	ITEM AMT
CONEEN CONSTELLATION NEW ENERGY							
0025012294	06/26/15	01	ACCT#1-EI-2497	31-001-002-4260		06/26/15	316.03
				UTILITIES		INVOICE TOTAL:	316.03
0025176328	06/26/15	01	ACCT#1-EI-1963	30-001-002-4260		06/26/15	3,833.98
				UTILITIES		INVOICE TOTAL:	3,833.98
						VENDOR TOTAL:	4,185.28
ENCS ENTRE COMPUTER SOLUTIONS							
00093249	06/29/15	01	INV#00093249	01-002-005-4906		06/29/15	5,400.00
				EQUIPMENT		INVOICE TOTAL:	5,400.00
						VENDOR TOTAL:	5,400.00
GEOBRU GEORGE BRUST							
JUNE 2015	06/26/15	01	MEETINGS FOR JUNE 2015	01-001-002-4290		06/26/15	28.82
				TRAVEL EXPENSE		INVOICE TOTAL:	28.82
						VENDOR TOTAL:	28.82
HACH HACH COMPANY							
9402491	06/25/15	01	INV#9402491	30-001-003-4680		06/25/15	273.67
				OPERATING SUPPLIES		INVOICE TOTAL:	273.67
						VENDOR TOTAL:	273.67
HDSUWA HD SUPPLY WATERWORKS LTD							
E004013	06/25/15	01	INV#E004013	30-001-005-4960		06/25/15	4,248.12
				METERS/EQUIPMENTS		INVOICE TOTAL:	4,248.12
						VENDOR TOTAL:	4,248.12

DATE: 06/30/15
 TIME: 08:18:00
 ID: AP441000.WOW

VILLAGE OF HAMPSHIRE
 DETAIL BOARD REPORT

INVOICES DUE ON/BEFORE 06/30/2015

INVOICE #	INVOICE DATE	ITEM #	DESCRIPTION	ACCOUNT #	P.O. #	DUE DATE	ITEM AMT
IPODBA			IPO/DBA CARDUNAL OFFICE SUPPLY				
572523-0	06/25/15	01	INV#572523-0	01-001-003-4650 OFFICE SUPPLIES		06/25/15	183.00
						INVOICE TOTAL:	183.00
572710-0	06/30/15	01	INV#572710-0	01-002-003-4650 OFFICE SUPPLIES		06/30/15	226.34
						INVOICE TOTAL:	226.34
						VENDOR TOTAL:	409.34
IPRF			ILLINOIS PUBLIC RICK FUND				
30325	06/25/15	01	INV#30325	01-001-002-4210 LIABILITY/WKRS COMP		06/25/15	1,588.66
		02	INV#30325	30-001-002-4210 LIABILITY INSURANCE			1,588.67
		03	INV#30325	31-001-002-4210 LIABILITY INSURANCE			1,588.67
						INVOICE TOTAL:	4,766.00
						VENDOR TOTAL:	4,766.00
KACOAN			KANE COUNTY ANIMAL CONTROL				
MAY	06/25/15	01	STRAYS PICKED UP IN MAY 2015	01-002-002-4380 OTHER PROF.SERV.		06/25/15	125.00
						INVOICE TOTAL:	125.00
						VENDOR TOTAL:	125.00
KACOU			KANE COUNTY RECORDER				
MAY 2015	06/25/15	01	TRAN 154718	01-001-002-4340 PRINT/ADV/FORMS		06/25/15	79.00
		02	TRAN 152067	30-001-002-4340 PRINTING/ADVERTISING/FORMS			47.00
						INVOICE TOTAL:	126.00
						VENDOR TOTAL:	126.00

DATE: 06/30/15
 TIME: 08:18:00
 ID: AP441000.WOW

VILLAGE OF HAMPSHIRE
 DETAIL BOARD REPORT

INVOICES DUE ON/BEFORE 06/30/2015

INVOICE #	INVOICE DATE	ITEM #	DESCRIPTION	ACCOUNT #	P.O. #	DUE DATE	ITEM AMT
NICOR	NICOR						
062615	06/26/15	01	ACCT#87-56-68-1000 5	31-001-002-4260 UTILITIES		06/26/15	391.23
						INVOICE TOTAL:	391.23
0626151	06/26/15	01	ACCT#19-61-05-1000 0	31-001-002-4260 UTILITIES		06/26/15	23.98
						INVOICE TOTAL:	23.98
						VENDOR TOTAL:	415.21
OSEL	O'SHEA ELECTRIC, INC						
9168	06/29/15	01	INV#9168	01-003-002-4270 STREET LIGHT MAINT.		06/29/15	450.00
						INVOICE TOTAL:	450.00
9169	06/29/15	01	INV#9169	01-003-002-4270 STREET LIGHT MAINT.		06/29/15	760.00
						INVOICE TOTAL:	760.00
						VENDOR TOTAL:	1,210.00
PEBASO	PETER BAKER & SON CO.						
35853MB	06/25/15	01	INV#35853MB	01-003-002-4130 MAINTENANCE - STREETS		06/25/15	243.49
						INVOICE TOTAL:	243.49
						VENDOR TOTAL:	243.49
PITB	PITNEY BOWES						
6208210-JL15	06/26/15	01	ACCT#6208210	01-001-002-4280 RENTAL - CARPET-WATER COOL		06/26/15	42.00
		02	ACCT#6208210	01-003-002-4280 RENTALS			42.00
		03	ACCT#6208210	31-001-002-4280 RENTAL SERVICES			42.00

INVOICES DUE ON/BEFORE 06/30/2015

INVOICE #	INVOICE DATE	ITEM #	DESCRIPTION	ACCOUNT #	P.O. #	DUE DATE	ITEM AMT
PITB	PITNEY BOWES						
6208210-JL15	06/26/15	04	ACCT#6208210 RENTAL SERVICE	30-001-002-4280		06/26/15	42.00
						INVOICE TOTAL:	168.00
						VENDOR TOTAL:	168.00
PLRE	PLANNING RESOURCES INC.						
11837	06/29/15	01	INV#11837 SPEEDWAY DEPOSIT	01-000-000-2057		06/29/15	303.75
						INVOICE TOTAL:	303.75
						VENDOR TOTAL:	303.75
QUCO	QUILL CORPORATION						
5114384	06/29/15	01	ACCT#C2221356 MAINTENANCE SUPPLIES	01-003-003-4670		06/29/15	173.91
						INVOICE TOTAL:	173.91
						VENDOR TOTAL:	173.91
RKQUSE	RK QUALITY SERVICES						
3096	06/30/15	01	INV#3096 MAINTENANCE - VEHL.	01-002-002-4110		06/30/15	2,101.17
						INVOICE TOTAL:	2,101.17
3154	06/25/15	01	INV#3154 MAINTENANCE - VEHL.	01-002-002-4110		06/25/15	33.75
						INVOICE TOTAL:	33.75
3158	06/25/15	01	INV#3158 MAINTENANCE - VEHL.	01-002-002-4110		06/25/15	36.00
						INVOICE TOTAL:	36.00
3175	06/25/15	01	INV#3175 MAINTENANCE - VEHL.	01-002-002-4110		06/25/15	240.64
						INVOICE TOTAL:	240.64

INVOICES DUE ON/BEFORE 06/30/2015

INVOICE #	INVOICE DATE	ITEM #	DESCRIPTION	ACCOUNT #	P.O. #	DUE DATE	ITEM AMT
3176	06/25/15	01	INV#3176	01-002-002-4110		06/25/15	36.75
				MAINTENANCE - VEHL.			
				INVOICE TOTAL:			36.75
3184	06/25/15	01	INV#3184	01-002-002-4110		06/25/15	36.82
				MAINTENANCE - VEHL.			
				INVOICE TOTAL:			36.82
				VENDOR TOTAL:			2,485.13
SUBLAB SUBURBAN LABORATORIES, INC							
122795	06/25/15	01	INV#122795	31-001-002-4380		06/25/15	198.50
				OTHR PROF. SERVICES			
				INVOICE TOTAL:			198.50
123208	06/25/15	01	INV#123208	31-001-002-4380		06/25/15	110.00
				OTHR PROF. SERVICES			
				INVOICE TOTAL:			110.00
123571	06/25/15	01	INV#123571	31-001-002-4380		06/25/15	200.00
				OTHR PROF. SERVICES			
				INVOICE TOTAL:			200.00
123712	06/25/15	01	INV#123712	30-001-002-4380		06/25/15	306.00
				OTHR PROF. SERVICES			
				INVOICE TOTAL:			306.00
123800	06/25/15	01	ACCT#123800	31-001-002-4380		06/25/15	143.50
				OTHR PROF. SERVICES			
				INVOICE TOTAL:			143.50
123807	06/25/15	01	INV#123807	31-001-002-4380		06/25/15	500.00
				OTHR PROF. SERVICES			
				INVOICE TOTAL:			500.00
				VENDOR TOTAL:			1,458.00

DATE: 06/30/15
 TIME: 08:18:00
 ID: AP441000.WOW

VILLAGE OF HAMPSHIRE
 DETAIL BOARD REPORT

INVOICES DUE ON/BEFORE 06/30/2015

INVOICE #	INVOICE DATE	ITEM #	DESCRIPTION	ACCOUNT #	P.O. #	DUE DATE	ITEM AMT
TOSQ			TOWNSQUARE				
6293	06/25/15	01	WXXQ-FM WZOK-FM	07-002-002-4376		06/25/15	2,003.00
				COON CREEK CONTRIBUTION			
				INVOICE TOTAL:			2,003.00
				VENDOR TOTAL:			2,003.00
USBL			USA BLUEBOOK				
655258	06/25/15	01	INV#655258	31-001-003-4670		06/25/15	522.30
				MAINTENANCE SUPPLIES			
				INVOICE TOTAL:			522.30
				VENDOR TOTAL:			522.30
VWPD			VERIZON WIRELESS				
9747408104	06/26/15	01	ACCT#880495288-00001	01-002-002-4230		06/26/15	30.98
				COMMUNICATION SERVICES			
				INVOICE TOTAL:			30.98
				VENDOR TOTAL:			30.98
VWVH			VERIZON WIRELESS				
9747408105	06/26/15	01	ADM	01-001-002-4230		06/26/15	65.14
				COMMUNICATION SERVICES			
		02	PD	01-002-002-4230			260.76
		03	STR	01-003-002-4230			86.51
		04	WTR	30-001-002-4230			26.97
		05	SWR	COMMUNICATION SERVICES			43.05
				31-001-002-4230			
				COMMUNICATIONS SERVICES			
				INVOICE TOTAL:			482.43
				VENDOR TOTAL:			482.43
WAMA			WASTE MANAGEMENT				

DATE: 06/30/15
TIME: 08:18:00
ID: AP441000.WOW

VILLAGE OF HAMPSHIRE
DETAIL BOARD REPORT

INVOICES DUE ON/BEFORE 06/30/2015

INVOICE #	INVOICE DATE	ITEM #	DESCRIPTION	ACCOUNT #	P.O. #	DUE DATE	ITEM AMT
3470606-2011-4	06/26/15	01	INV#3470606-2011-4	29-001-002-4330		06/26/15	45.48
				GARBAGE DISPOSAL			
							INVOICE TOTAL: 45.48
							VENDOR TOTAL: 45.48
							TOTAL ALL INVOICES: 44,522.09