

Village of Hampshire  
Village Board Meeting  
Thursday May 2, 2019 – 7:00 PM  
Hampshire Village Hall – 234 S. State Street

## AGENDA

---

1. Call to Order
2. Establish Quorum (Physical and Electronic)
3. Pledge of Allegiance
4. Citizen Comments
5. Approval of Minutes April 18, 2019
6. Village President's Report
  - a) Sergeant Marshall Alexander from the United States Marine Corps.
  - b) Appoint Lawrence Rapach to Plan Commission expire May 2022.
  - c) Ordinance amending the Village's Liquor regulations to create an additional license in the C-2 license category in the Village.
  - d) Ordinance amending the Village's Liquor regulations to create an additional license in the B-2 license category in the Village.
  - e) Approve purchasing two snow plow trucks.
  - f) 2019 Road Improvements
7. Village Board Committee Reports
  - a) Economic Development
  - b) Planning/Zoning
  - c) Public Safety
  - d) Fields & Trails
  - e) Village Services
  - f) Public Works
  - g) Business Development Commission
  - h) Finance
    1. Accounts Payable
8. New Business
9. Announcements
10. Executive Session
11. Any items to be reported and acted upon by the Village Board after returning to open session

## **Adjournment, sine die**

### Ceremonial Proceedings:

A. Presentation of Plaque/Outgoing Elected Official- Jan Kraus

### **Administer Oath of Office:**

Trustees' Arron L. Kelly, Erik Robinson, and Toby Koth by Clerk Linda Vasquez

12. Village Board Reconvened – Call to Order & Establishment of Quorum

13. New Business

14. Adjournment

The Village of Hampshire, in compliance with the Americans With Disabilities Act, requests that persons with disabilities, who require certain accommodations to allow them to observe and/or participate in the meeting(s) or have questions about the accessibility of the meeting(s) or facilities, contact the Village at 847-683-2181 to allow the Village to make reasonable accommodations for these persons

**VILLAGE OF HAMPSHIRE  
REGULAR MEETING OF THE BOARD OF TRUSTEES  
MINUTES  
April 18, 2019**

The regular meeting of the Village Board of Hampshire was called to order by Village President Jeffrey Magnussen at 7:00 PM in the Village of Hampshire Village Board Room, 234 S. State Street, on Thursday, April 18, 2019.

Present: Christine Klein, Ryan Krajecki, Janet Kraus, Toby Koth, Erik Robinson, Michael Reid.

Absent: None

Also Present: Village Clerk Linda Vasquez, Village Finance Director Lori Lyons, Village Police Chief Brian Thompson, Village Engineer Julie Morrison, and Village Attorney Mark Schuster.

A quorum was established.

President Magnussen led the Pledge of Allegiance.

**MINUTES**

Trustee Robinson moved to approve the minutes of April 4, 2019, with the change concerning Peter Raphael on page two. Mr. Raphael is from DA Davidson, not Speer Financial.

Seconded by Trustee Kraus  
Motion carried by voice vote  
Ayes: Klein, Koth, Krajecki, Robinson, Kraus, Reid  
Nays: None  
Absent: None

Trustee Krajecki moved to approve moving item H under the Village President report to follow item C.

Seconded by Trustee Klein  
Motion carried by voice vote.  
Ayes: Klein, Koth, Krajecki, Robinson, Kraus, Reid  
Nays: None  
Absent: None

**Public Hearing**

Village President Magnussen opened the public hearing at 7:03 PM

The hearing is to allow residents to provide comment on the FY 2019/20 budget. The notice was published in the Daily Herald Newspaper April 11, 2019, and was made available for the public to view.

Finance Director Ms. Lyons presented a synopsis of 2019/2020 budget and highlighted some key points in the budget.

Ms. Lyons thanked the Finance Committee and village staff for their input.

No public comments were made.

Trustee Klein thanked her committee for doing a fine job working on the budget.

Village President Magnussen closed the public hearing at 7:12 PM

The regular village board meeting was called to order at 7:12 PM

## VILLAGE PRESIDENT REPORT

Sergeant Marshall Alexander from the United States Marine Corps will reschedule, as he had someone who wanted to join him but was unable to attend.

Trustee Reid moved to reappoint Police Pension - David Scarpino, with his term to expire in 2021.

Seconded by Trustee Koth  
Motion carried by voice vote.  
Ayes: Klein, Koth, Krajecki, Robinson, Kraus, Reid  
Nays: None  
Absent: None

Trustee Robinson moved to reappoint Planning Commissioner Aaron Neal, with his term to expire in 2022.

Seconded by Trustee Kraus  
Motion carried by voice vote.  
Ayes: Klein, Koth, Krajecki, Robinson, Kraus, Reid  
Nays: None  
Absent: None

Troy Paionk –senior project manager from BSTP Midwest, LLC reported that the closing of sale should be August 15, 2019. After the closing, they will be improving the road, and the business will remain closed for 12-14 months. A six month buildout for the site is planned.

Trustee Reid moved to approve Resolution 19-10 approving a certain Economic Incentive Agreement with Thornton's (19N479 US Highway 20), pending the supplemental letter addressing Section 6 – b of said resolution.

Seconded by Trustee Robinson  
Motion carried by roll call vote.  
Ayes: Klein, Koth, Robinson, Reid  
Nays: Kraus, Krajecki  
Absent: None

Trustee Krajecki made it clear he did not support the Village giving Thornton's an incentive agreement. Trustee Krajecki stated that a large company like Thornton's, who are located throughout the country and worth millions of dollars, should be able to sustain this project on their own without any help from the village.

Village President Magnussen announced that there will be a tree planted in Henpeck in honor of Arbor Day on Friday, April 26, 2019 at 11:00 AM.



Trustee Krajecki moved to approve Ordinance 19-08; authorizing disposal of obsolete property.

Seconded by Trustee Klein  
Motion carried by roll call vote.  
Ayes: Klein, Krajecki, Robinson, Reid  
Nays: Koth, Kraus  
Absent: None

Trustee Krajecki moved to approve the Fiscal Budget for May 1, 2019 to April 30, 2020 Ordinance 19-09; Adopting the Budget for the Village of Hampshire for the Fiscal Year Beginning May 1, 2019 and Ending April 30, 2020.

Seconded by Trustee Klein  
Motion carried by roll call vote.  
Ayes: Klein, Krajecki, Koth, Robinson, Reid  
Nays: Kraus  
Absent: None

Trustee Klein mentioned that the process of creating the budget was successful after many meetings and all the hard work that everyone put forth. She expressed her thanks to all.

Trustee Krajecki moved, to accept Option 2 of BDA Moreau for the Employee Assistance Program with implementation starting May 1, 2019.

Seconded by Trustee Reid  
Motion carried by roll call vote.  
Ayes: Klein, Koth, Krajecki, Robinson, Reid  
Nays: Kraus  
Absent: None

## **VILLAGE BOARD COMMITTEE REPORTS**

### **a. Accounts Payable:**

Trustee Klein moved to approve the Accounts Payable in the sum of \$287.74 to employees Brett Meyer and Mark Montgomery to be paid on or before April 24, 2019.

Seconded by Trustee Robinson  
Motion carried by roll call vote  
Ayes: Klein, Krajecki, Kraus, Robinson, and Reid  
Nays: Koth  
Absent: None

Trustee Klein moved to approve the Accounts Payable in the sum of \$191,151.31 to be paid on or before April 10, 2019.

Seconded by Trustee Krajecki  
Motion carried by roll call vote  
Ayes: Klein, Koth, Krajecki, Robinson, and Reid  
Nays: Kraus  
Absent: None

Trustee Klein reported that a finance committee workshop with the village board of trustees meeting will be on April 23, at 6:30 PM at Village Hall.

- b. **Economic Development**: Trustee Reid said the chamber guide is finished and is ready to go out. Thank you everyone who helped out in this project.
- c. **Planning/Zoning**: A Planning Commission meeting will be held at Village Hall on Monday, April 22, 2019 at 7:00 PM in regard to the 55 and older senior living land lease community.
- d. **Public Safety**- No report.
- e. **Fields & Trails**: No report
- f. **Village Services**: No report
- g. **Public Works**: No report
- h. **Business Development Commission**: Trustee Krajecki reported that the Commission is continuing to work on the Main Street program with Ms. Kopacz. The Hampshire Chamber of Commerce and the BDC will be emailing out a survey to the businesses to get some input from their prospective. The next BDC committee meeting will be on May 8 at 6:30 PM.

A question was asked: Did Eileen Fleury Resign from the BDC?

### **ANNOUNCEMENTS**

It was mentioned that there is a great deal of trash blowing around by the Citgo truck stop. The area around the truck stop looks unclean. Chief Thompson would look into the area.

### **ADJOURNMENT**

Trustee Krajecki moved to adjourn the Village Board meeting at 8:16 PM.

Seconded by Trustee Kraus  
Motion carried by voice vote  
Ayes: Klein, Kraus, Koth, Krajecki, Robinson, and Reid  
Nays: None  
Absent: None

---

Linda Vasquez Village Clerk

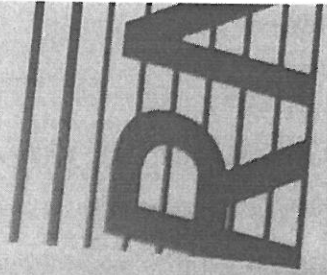

# Lawrence M. Rapach

1541 Bristol Drive  
Hampshire, IL 60140  
847-322-9603 (Mobile)

## Work History:

- Specialist (2yr - current)  
Litigation  
Action Defect, Product Liability, Completed Operations, e
- Supervisor/Lead – 6yr)
- Truck Supervisor (Premise GL, CO/PL)
- Garage Supervisor (Garage Keepers & Completed Ops. BI)
- al Supervisor (Product, Comp Ops. Premise: PD/BI/Lit)

**AN ORDINANCE  
AMENDING THE VILLAGE'S LIQUOR REGULATIONS TO CREATE  
AN ADDITIONAL LICENSE IN THE C-2 LICENSE CATEGORY  
IN THE VILLAGE**

WHEREAS, the Village has adopted regulations governing the types and characteristics of various classifications of licenses allowing for the retail sale of alcoholic beverages and package goods in the Village; and

WHEREAS, included in said regulations is a limitation in number for each of the various classifications of license available in the Village; and

WHEREAS, the Village has received an application for a new C-2 category liquor license for a restaurant serving alcohol liquors with food, to be located at 113 Oak Knoll Drive, Unit 115, in the Village; and

WHEREAS, the Liquor Commission has reviewed the application and has considered the creation of a new license in the C-2 category, and recommends creation of the license for issuance to said applicant, subject to its compliance with all rules and regulations; and

WHEREAS, the Corporate Authorities find it advisable to create one additional license in the C-2 license classification at this time.

NOW THEREFORE BE IT ORDAINED BY THE PRESIDENT AND BOARD OF TRUSTEES OF THE VILLAGE OF HAMPSHIRE, KANE COUNTY, ILLINOIS, AS FOLLOWS:

Section 1. The Hampshire Municipal Code of 1985, as previously amended, shall be and hereby is further amended to create one new license in the B-1 Liquor License Classification, in words and figures as follows:

CHAPTER 3	LIQUOR REGULATIONS
ARTICLE I	ALCOHOLIC LIQUOR REGULATIONS
SECTION 3-1-6	CLASSIFICATION OF LICENSES; FEES, CLOSING HOURS

N. Number of licenses: The number of alcoholic liquor licenses to be issued in the Village shall be as follows:

Class A-1	Taverns/Carry Out	3
Class A-2	Taverns/No Carry Out	0
Class B-1	Package Sales	3
Class B-2	Package Sales/Convenience Store	4
Class C-1	Restaurant/Retail Sale – beer, wine	1
Class C-2	Restaurant/Service with food	3
Class C-3	Restaurant/Outdoor Seating	2
Class C-4	Restaurant/On Premises	0
Class D	Hotels/Motels	0
Class E	Banquet Halls	0
Class F	Clubs	0
Class G	Special Events	N/A
Class H	Beauty Salons/Spas	0
Class I	Park District	1
Total		<hr/> 17

Section 2. The license may be issued to Lucky Tavern LLC, or such other business entity of which Mary Ann Bollman and/or Dana Bollman are shareholders or members, and upon filing evidence of same, a surety bond, a certificate of liability insurance, including dram shop coverage, and a copy of a written lease for the proposed location of the business.

Section 3. All ordinances, resolutions and orders, or parts thereof, in conflict with the provisions of this Ordinance are, to the extent of such conflict, hereby superseded and waived.

Section 4. If any section, subdivision, sentence or phrase of this Ordinance is for any reason held to be void, invalid, or unconstitutional, such decision shall not affect the validity of the remaining portion of this Ordinance.

Section 5. This Ordinance shall be in full force and effect upon passage, approval, and publication in pamphlet form, as provided by law.

ADOPTED THIS \_\_\_\_ DAY OF \_\_\_\_\_, 2019 pursuant to roll call vote as follows:

AYES: \_\_\_\_\_

NAYS: \_\_\_\_\_

ABSTAIN: \_\_\_\_\_

ABSENT: \_\_\_\_\_

APPROVED THIS \_\_\_\_\_ DAY OF \_\_\_\_\_, 2019.

---

Jeffrey R. Magnussen  
Village President

ATTEST:

---

Linda Vasquez  
Village Clerk

CERTIFICATE

The undersigned hereby certifies:

1. I am the Village Clerk for the Village of Hampshire, Kane County, Illinois.
2. On \_\_\_\_\_, 2019, the Corporate Authorities of the Village enacted this Ordinance No. 19 - \_\_\_\_\_, which provided by its terms that it shall be published in pamphlet form.
3. The pamphlet form of this Ordinance was duly prepared by me, and a copy of said Ordinance was thereafter posted in the Village Hall at 234 South State Street in the Village, commencing on \_\_\_\_\_, 2019 and continuing thereafter for at least the next following ten (10) days.
4. A copy of this Ordinance was also available for public inspection, after the date of its enactment, and upon request, at the Office of the Village Clerk.

---

Linda Vasquez  
Village Clerk



**AN ORDINANCE  
AMENDING THE VILLAGE'S LIQUOR REGULATIONS TO CREATE  
AN ADDITIONAL LICENSE IN THE B-2 LICENSE CATEGORY  
IN THE VILLAGE**

WHEREAS, the Village has adopted regulations governing the types and characteristics of various classifications of licenses allowing for the retail sale of alcoholic beverages and package goods in the Village; and

WHEREAS, included in said regulations is a limitation in number for each of the various classifications of license available in the Village; and

WHEREAS, the Village has received an application for a new B-2 category liquor license for Loves Travel Stops & Country Stores to be located at 201-A Loves Crossing in the Village, for sale at retail of beer and wine only for consumption off the premises only; at a convenience store; and

WHEREAS, the Liquor Commission has reviewed the application and has considered the creation of a new license in the B-2 category, and recommends creation of the license for issuance to said applicant; and

WHEREAS, the Corporate Authorities find it advisable to create one additional license in the B-2 license classification at this time.

NOW THEREFORE BE IT ORDAINED BY THE PRESIDENT AND BOARD OF TRUSTEES OF THE VILLAGE OF HAMPSHIRE, KANE COUNTY, ILLINOIS, AS FOLLOWS:

Section 1. The Hampshire Municipal Code of 1985, as previously amended, shall be and hereby is further amended to create one new license in the B-2 Liquor License Classification, in words and figures as follows:

CHAPTER 3	LIQUOR REGULATIONS
ARTICLE I	ALCOHOLIC LIQUOR REGULATIONS
SECTION 3-1-6	CLASSIFICATION OF LICENSES; FEES, CLOSING HOURS

N. Number of licenses: The number of alcoholic liquor licenses to be issued in the Village shall be as follows:



Class A-1	Taverns/Carry Out	3
Class A-2	Taverns/No Carry Out	0
Class B-1	Package Sales	3
Class B-2	Package Sales/Convenience Store	5
Class C-1	Restaurant/Retail Sale – beer, wine	1
Class C-2	Restaurant/Service with food	3
Class C-3	Restaurant/Outdoor Seating	2
Class C-4	Restaurant/On Premises	0
Class D	Hotels/Motels	0
Class E	Banquet Halls	0
Class F	Clubs	0
Class G	Special Events	N/A
Class H	Beauty Salons/Spas	0
Class I	Park District	1
Total		<u>18</u>

Section 2. All ordinances, resolutions and orders, or parts thereof, in conflict with the provisions of this Ordinance are, to the extent of such conflict, hereby superseded and waived.

Section 3. If any section, subdivision, sentence or phrase of this Ordinance is for any reason held to be void, invalid, or unconstitutional, such decision shall not affect the validity of the remaining portion of this Ordinance.

Section 4. This Ordinance shall be in full force and effect upon passage, approval, and publication in pamphlet form, as provided by law.

ADOPTED THIS \_\_\_\_ DAY OF \_\_\_\_\_, 2019 pursuant to roll call vote as follows:

AYES: \_\_\_\_\_

NAYS: \_\_\_\_\_

ABSTAIN: \_\_\_\_\_

ABSENT: \_\_\_\_\_

APPROVED THIS \_\_\_\_\_ DAY OF \_\_\_\_\_, 2019.

---

Jeffrey R. Magnussen  
Village President

ATTEST:

---

Linda Vasquez  
Village Clerk

CERTIFICATE

The undersigned hereby certifies:

1. I am the Village Clerk for the Village of Hampshire, Kane County, Illinois.
2. On \_\_\_\_\_, 2019, the Corporate Authorities of the Village enacted this Ordinance No. 19 - \_\_\_\_\_, which provided by its terms that it shall be published in pamphlet form.
3. The pamphlet form of this Ordinance was duly prepared by me, and a copy of said Ordinance was thereafter posted in the Village Hall at 234 South State Street in the Village, commencing on \_\_\_\_\_, 2019 and continuing thereafter for at least the next following ten (10) days.
4. A copy of this Ordinance was also available for public inspection, after the date of its enactment, and upon request, at the Office of the Village Clerk.

---

Linda Vasquez  
Village Clerk



---

---

## AGENDA SUPPLEMENT

---

---

**TO:** President Magnussen and Village Board  
**FROM:** Lori Lyons, Finance Director  
**FOR:** May 2, 2019 Village Board Meeting  
**RE:** Purchase Two Snow Plow Trucks

---

**Background.** The FY20 operating budget included the acquisition of two Snow Plow/Dump trucks to aid snow and other operations in the Street Division. Financing will be either via a five year note or a five year lease following a 20% down payment. Staff obtained bids from Rush Truck Center (state bid) and Truck Country for the cab and chassis and from Bonnell Industries and Monroe Truck Equipment for the upfit. Due to the lead time required, it is best to order these trucks immediately.

**Analysis.** Each truck will be equipped with a stainless steel dump body, plow, under tailgate spreader, live PTO and trailer connection per the attached quotations. These heavy duty trucks are furnished and sized to suit multiple applications including snow operations and trailering of equipment to jobsites. Equipment is operated by hydraulics. Delivery of the cab and chassis generally takes 16 weeks or longer following initiation of the order while the upfit wouldn't start until late January with Bonnell but can start in September for Monroe, based on their current schedules. A summary of the price quotes is as follows:

	Rush Truck Center International VH607	Truck Country Freightliner 108SD
Cab and Chassis	84,339	81,480
	Bonnell	Monroe
Upfit	71,950	66,022

Street Superintendent David Starrett's recommendation is to go with Freightliners upfitted by Monroe Truck Equipment. This combo is less expensive and the trucks should be delivered in October (vs. mid-February to possibly March with Bonnell) leading to potential savings on contracted plowing services.

**Recommendation.** Staff requests authorization to sign purchase documents for two new 2020 Freightliner 108SD plow trucks with stainless steel dump body and related equipment from Monroe Truck Equipment in the amount of \$147,482 per unit.

**INTERNATIONAL®**

April 04, 2019

**Prepared For:**  
Hampshire, Village of  
DAVE STARRETT  
PO Box 457  
Hampshire, IL 60140-0457  
(847)683 - 4044  
Reference ID: SOURCEWELL 2019

**Presented By:**  
RUSH TRK CTR OF N IL  
David R Mueller  
4655 S CENTRAL AVE.  
CHICAGO IL 606381547  
708-496-7500

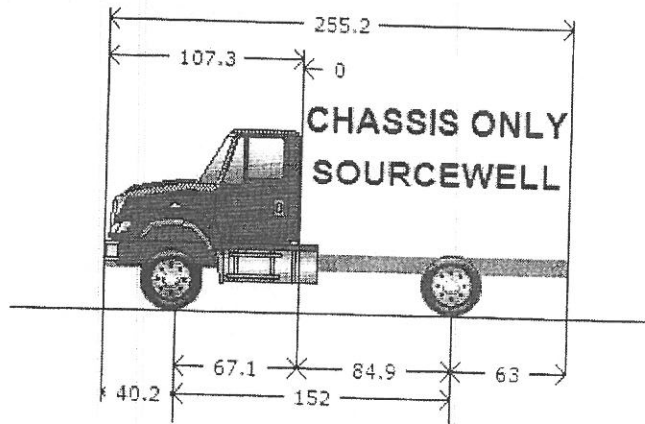

**Model Profile**  
2020 HV607 SBA (HV607)

<b>AXLE CONFIG:</b>	4X2
<b>MISSION:</b>	Requested GVWR: 37000. Calc. GVWR: 37000
<b>DIMENSION:</b>	Wheelbase: 152.00, CA: 84.90, Axle to Frame: 63.00
<b>ENGINE, DIESEL:</b>	{Cummins L9 330} EPA 2017, 330HP @ 2000 RPM, 1000 lb-ft Torque @ 1400 RPM, 2200 RPM Governed Speed, 330 Peak HP (Max)
<b>TRANSMISSION, AUTOMATIC:</b>	{Allison 3000 RDS} 5th Generation Controls, Close Ratio, 6-Speed with Double Overdrive, with PTO Provision, Less Retarder, Includes Oil Level Sensor, with 80,000-lb GVW and GCW Max, On/Off Highway
<b>CLUTCH:</b>	Omit Item (Clutch & Control)
<b>AXLE, FRONT NON-DRIVING:</b>	{Meritor MFS-16-143A} Wide Track, I-Beam Type, 16,000-lb Capacity
<b>AXLE, REAR, SINGLE:</b>	{Meritor MS-21-14X-4DCR} Single Reduction, 21,000-lb Capacity, Driver Controlled Locking Differential, R Wheel Ends Gear Ratio: 6.43
<b>CAB:</b>	Conventional, Day Cab
<b>TIRE, FRONT:</b>	(2) 315/80R22.5 Load Range L HSC1 (CONTINENTAL), 484 rev/mile, 68 MPH, All-Position
<b>TIRE, REAR:</b>	(4) 11R22.5 Load Range G HDR2 (CONTINENTAL), 491 rev/mile, 75 MPH, Drive
<b>SUSPENSION, REAR, SINGLE:</b>	23,500-lb Capacity, Vari-Rate Springs
<b>PAINT:</b>	Cab schematic 100WL Location 1: 2303, Red (Std) Chassis schematic N/A

**Description**

Base Chassis, Model HV607 SBA with 152.00 Wheelbase, 84.90 CA, and 63.00 Axle to Frame.

TOW HOOK, FRONT (2) Frame Mounted

AXLE CONFIGURATION {Navistar} 4x2

FRAME RAILS Heat Treated Alloy Steel (120,000 PSI Yield); 10.866" x 3.622" x 0.437" (276.0mm x 92.0mm x 11.1mm); 456.0" (11582mm) Maximum OAL

BUMPER, FRONT Swept Back, Steel, Heavy Duty

FRAME EXTENSION, FRONT Integral; 20" In Front of Grille

WHEELBASE RANGE 138" (350cm) Through and Including 187" (475cm)

AXLE, FRONT NON-DRIVING {Meritor MFS-16-143A} Wide Track, I-Beam Type, 16,000-lb Capacity

SHOCK ABSORBERS, FRONT

SPRINGS, FRONT AUXILIARY Rubber

SUSPENSION, FRONT, SPRING Multileaf, Shackle Type, 16,000-lb Capacity, Less Shock Absorbers

BRAKE SYSTEM, AIR Dual System for Straight Truck Applications

BRAKES, FRONT, AIR CAM 16.5" x 6", Includes 24 SqIn Long Stroke Brake Chambers

TRAILER CONNECTIONS Four-Wheel, with Hand Control Valve and Tractor Protection Valve, for Straight Truck

DRAIN VALVE {Bendix DV-2} Automatic, with Heater, for Air Tank

AIR BRAKE ABS {Bendix AntiLock Brake System} Full Vehicle Wheel Control System (4-Channel)

AIR DRYER {Bendix AD-9} with Heater

BRAKE CHAMBERS, REAR AXLE {Bendix EverSure} 30/30 Spring Brake

BRAKE CHAMBERS, FRONT AXLE {Bendix} 24 SqIn

BRAKES, REAR, AIR CAM S-Cam; 16.5" x 7.0"; Includes 30/30 Sq.In. Long Stroke Brake Chamber and Spring Actuated Parking Brake

AIR COMPRESSOR {Cummins} 18.7 CFM

AIR DRYER LOCATION Mounted Inside Left Rail, Back of Cab

AIR TANK LOCATION (2) Mounted Under Battery Box, Outside Right Rail, Back of Cab, Perpendicular to Rail

STEERING COLUMN Tilting and Telescoping

STEERING WHEEL 4-Spoke; 18" Dia., Black

STEERING GEAR {Sheppard M110} Power

DRIVESHAFT {Dana Spicer} SPL140 in lieu of 1710 Series

AFTERTREATMENT COVER Steel, Black

EXHAUST SYSTEM Single Horizontal Aftertreatment Device, Frame Mounted Right Side Under Cab; for Single Vertical Tail Pipe, Frame Mounted Right Side Back of Cab

TAIL PIPE (1) Turnback Type, Non-Bright, for Single Exhaust

EXHAUST HEIGHT 10'

MUFFLER/TAIL PIPE GUARD (1) Non-Bright Aluminum

ELECTRICAL SYSTEM 12-Volt, Standard Equipment

CIGAR LIGHTER Includes Ash Cup

**Description**

ALTERNATOR {Leece-Neville AVI160P2012} Brush Type; 12 Volt 190 Amp. Capacity, Pad Mount, with Remote Sense

BODY BUILDER WIRING Back of Day Cab at Left Frame or Under Sleeper, Extended or Crew Cab at Left Frame; Includes Sealed Connectors for Tail/Amber Turn/Marker/ Backup/Accessory Power/Ground and Sealed Connector for Stop/Turn

BATTERY SYSTEM {Fleetrite} Maintenance-Free, (3) 12-Volt 1980CCA Total, Top Threaded Stud

2-WAY RADIO Wiring Effects; Wiring with 20 Amp Fuse Protection, Includes Ignition Wire with 5 Amp Fuse, Wire Ends Heat Shrink and Routed to Center of Header Console in Cab

RADIO AM/FM/WB/Clock/3.5MM Auxiliary Input

SPEAKERS (2) 6.5" Dual Cone Mounted in Doors

AUXILIARY HARNESS 3.0' for Auxiliary Front Head Lights and Turn Signals for Front Plow Applications

TRAILER CONNECTION SOCKET 7-Way; Mounted at Rear of Frame, Wired for Turn Signals Independent of Stop, Compatible with Trailers That Have Amber or Side Turn Lamps

HORN, ELECTRIC Disc Style

BATTERY BOX Steel, with Plastic Cover, 18" Wide, 2-4 Battery Capacity, Mounted Right Side Back of Cab

JUMP START STUD Remote Mounted

CLEARANCE/MARKER LIGHTS (5) {Truck Lite} Amber LED Lights, Flush Mounted on Cab or Sunshade

STARTING MOTOR {Delco Remy 38MT Type 300} 12 Volt; less Thermal Over-Crank Protection

INDICATOR, LOW COOLANT LEVEL with Audible Alarm

CIRCUIT BREAKERS Manual-Reset (Main Panel) SAE Type III with Trip Indicators, Replaces All Fuses

TURN SIGNALS, FRONT Includes LED Side Turn Lights Mounted on Fender

HORN, AIR Black, Single Trumpet, with Lanyard Pull Cord

LOGOS EXTERIOR Model Badges

LOGOS EXTERIOR, ENGINE Badges

INSULATION, UNDER HOOD for Sound Abatement

GRILLE Stationary, Chrome

INSULATION, SPLASH PANELS for Sound Abatement

FRONT END Tilting, Fiberglass, with Three Piece Construction; for WorkStar/HV

PAINT SCHEMATIC, PT-1 Single Color, Design 100

PAINT TYPE Base Coat/Clear Coat, 1-2 Tone

CUSTOMER IDENTITY for National Joint Powers Alliance

PROMOTIONAL PACKAGE Government Silver Package

CLUTCH Omit Item (Clutch & Control)

ANTI-FREEZE Red, Extended Life Coolant; To -40 Degrees F/ -40 Degrees C, Freeze Protection

BLOCK HEATER, ENGINE 120V/1000W, for Cummins ISB/B6.7/ISL/L9 Engines

ENGINE, DIESEL {Cummins L9 330} EPA 2017, 330HP @ 2000 RPM, 1000 lb-ft Torque @ 1400 RPM, 2200 RPM Governed Speed, 330 Peak HP (Max)

FAN DRIVE {Horton Drivemaster} Direct Drive Type, Two Speed with Residual Torque Device for Disengaged Fan Speed

RADIATOR Cross Flow, Series System; 1228 SqIn Aluminum Radiator Core and 1167 SqIn Charge Air Cooler



**Description**

AIR CLEANER Single Element, with Integral Snow Valve and In-Cab Control

FEDERAL EMISSIONS {Cummins L9} EPA, OBD and GHG Certified for Calendar Year 2019

THROTTLE, HAND CONTROL Engine Speed Control; Electronic, Stationary, Variable Speed; Mounted on Steering Wheel

EMISSION COMPLIANCE Federal, Does Not Comply with California Clean Air Idle Regulations

ENGINE CONTROL, REMOTE MOUNTED Provision for; Includes Wiring for Body Builder Installation of PTO Controls; with Ignition Switch Control for Cummins ISB/B6.7 or ISL/L9 Engines

TRANSMISSION, AUTOMATIC {Allison 3000 RDS} 5th Generation Controls, Close Ratio, 6-Speed with Double Overdrive, with PTO Provision, Less Retarder, Includes Oil Level Sensor, with 80,000-lb GVW and GCW Max, On/Off Highway

OIL COOLER, AUTO TRANSMISSION {Modine} Water to Oil Type

TRANSMISSION SHIFT CONTROL for Column Mounted Stalk Shifter

TRANSMISSION DIPSTICK Relocated to Right Side of Transmission

TRANSMISSION OIL Synthetic; 29 thru 42 Pints

ALLISON SPARE INPUT/OUTPUT for Rugged Duty Series (RDS); General Purpose Trucks, Construction

TRANSMISSION TCM LOCATION Located Inside Cab

SHIFT CONTROL PARAMETERS Allison 3000 or 4000 Series Transmissions, 5th Generation Controls, Performance Programming

PTO LOCATION Dual, Customer Intends to Install PTO at Left and/or Right Side of Transmission

AXLE, REAR, SINGLE {Meritor MS-21-14X-4DCR} Single Reduction, 21,000-lb Capacity, Driver Controlled Locking Differential, R Wheel Ends . Gear Ratio: 6.43

SUSPENSION, REAR, SINGLE 23,500-lb Capacity, Vari-Rate Springs

SPRINGS, REAR AUXILIARY Multileaf; 4,500-lb Capacity

FUEL TANK STRAPS Bright Finish Stainless Steel

DEF TANK 9.5 US Gal (36L) Capacity, Frame Mounted Outside Left Rail, Under Cab

FUEL/WATER SEPARATOR {Racor 400 Series,} 12 VDC Electric Heater, Includes Pre-Heater, with Primer Pump, Includes Water-in-Fuel Sensor

LOCATION FUEL/WATER SEPARATOR Mounted Outside Left Rail, 24" Back of Cab

FUEL TANK Top Draw, Non-Polished Aluminum, 26" Dia, 100 US Gal (379L), Mounted Left Side, Under Cab

CAB Conventional, Day Cab

AIR CONDITIONER with Integral Heater & Defroster

GAUGE CLUSTER Base Level; English with English Speedometer and Tachometer, for Air Brake Chassis, Includes Engine Coolant Temperature, Primary and Secondary Air Pressure, Fuel and DEF Gauges, Oil Pressure Gauge, Includes 3 Inch Monochromatic Text Display

GAUGE, OIL TEMP, AUTO TRANS for Allison Transmission

GAUGE, AIR CLEANER RESTRICTION {Filter-Minder} with Black Bezel, Mounted in Instrument Panel

IP CLUSTER DISPLAY On Board Diagnostics Display of Fault Codes in Gauge Cluster

SEAT, DRIVER {National 2000} Air Suspension, High Back with Integral Headrest, Vinyl, Isolator, 1 Chamber Lumbar, with 2 Position Front Cushion Adjust, -3 to +14 Degree Angle Back Adjust

GRAB HANDLE Chrome; Towel Bar Type with Anti-Slip Rubber Inserts; for Cab Entry Mounted Left Side Only at "B" Pillar

MIRROR, CONVEX, HOOD MOUNTED (2) {Lang Mekra} Heated, Left and Right Sides 7.44" Sq

**Description**

SEAT, PASSENGER {National} Non Suspension, High Back, Fixed Back, Integral Headrest, Vinyl

MIRRORS (2) Thermostatically Controlled Heated Heads, Black Heads, Brackets and Arms, 7.55" x 14.1" Flat Glass, 7.48" x 6.77" Convex Glass Both Sides

CAB INTERIOR TRIM Classic, for Day Cab

WINDSHIELD Heated, Single Piece

ARM REST, RIGHT, DRIVER SEAT

CAB REAR SUSPENSION Air Bag Type

WINDOW, MANUAL (2) and Manual Door Locks, Left and Right Doors

INSTRUMENT PANEL Flat Panel

COWL TRAY LID

ACCESS, CAB Steel, Driver & Passenger Sides, Two Steps per Door, for use with Day Cab and Extended Cab

WHEELS, FRONT {Accuride 29300} DISC; 22.5x9.00 Rims, Powder Coat Steel, 5-Hand Hole, 10-Stud, 285.75mm BC, Hub-Piloted, Flanged Nut, with Steel Hubs

WHEELS, REAR {Maxion 90541} DUAL DISC; 22.5x8.25 Rims, Painted Steel, 2-Hand Hole, 10-Stud, 285.75mm BC, Hub-Piloted, Flanged Nut, with Steel Hubs

PAINT IDENTITY, FRONT WHEELS Disc Wheels; with Vendor Applied Black Powder Coat Paint

PAINT IDENTITY, REAR WHEELS Disc Wheels; with Vendor Applied Black Powder Coat Paint

(4) TIRE, REAR 11R22.5 Load Range G HDR2 (CONTINENTAL), 491 rev/mile, 75 MPH, Drive

(2) TIRE, FRONT 315/80R22.5 Load Range L HSC1 (CONTINENTAL), 484 rev/mile, 68 MPH, All-Position

Cab schematic 100WL

Location 1: 2303, Red (Std)

Chassis schematic N/A

**Services Section:**

WARRANTY Standard for HV507, HV50B, HV607 Models, Effective with Vehicles Built July 1, 2017 or Later, CTS-2025A

MUNICIPAL LICENSE PLATES AND TITLE FEE

<u>Description</u>	(US DOLLAR)	<u>Price</u>
Net Sales Price:		\$84,339.00

ABOVE FIGURE IS FOR A CHASSIS ONLY (no body or mounted equipment ) FOR VILLAGE OF HAMPSHIRE

ABOVE FIGURE WAS CALCULATED USING SOURCEWELL CONTRACT # 081716 NVS

ABOVE FIGURES DO NOT INCLUDE ANY FUTURE/POTENTIAL INCREASES FOR THE FOLLOWING:  
EMISSION SURCAHRGES, FREIGHT / DESTINATION FEES and RAW MATERIAL SURCHARGES

Approved by Seller:

Accepted by Purchaser:

\_\_\_\_\_  
Official Title and Date

\_\_\_\_\_  
Firm or Business Name

\_\_\_\_\_  
Authorized Signature

\_\_\_\_\_  
Authorized Signature and Date

This proposal is not binding upon the seller without  
Seller's Authorized Signature

\_\_\_\_\_  
Official Title and Date

The TOPS FET calculation is an estimate for reference purposes only. The seller or retailer is responsible for calculating and reporting/paying appropriate FET to the IRS.

The limited warranties applicable to the vehicles described herein are Navistar, Inc.'s standard printed warranties which are incorporated herein by reference and to which you have been provided a copy and hereby agree to their terms and conditions.

**Prepared for:**  
Village Hampshire  
234 S State St  
Hampshire, IL 60140  
Phone: 847-683-2181

**Prepared by:**  
Luke Burbach  
TRUCK COUNTRY  
2222 WEST RYAN ROAD  
OAK CREEK, WI 53154  
Phone: 414-416-9553

*A proposal for*  
**Village of Hampshire**

*Prepared by*  
**TRUCK COUNTRY OF WISCONSIN**  
*Luke Burbach*

*Apr 17, 2019*

**Freightliner 108SD**

Components shown may not reflect all spec'd options and are not to scale

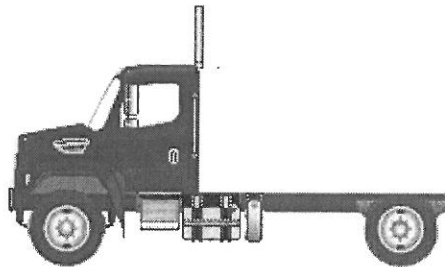

**Prepared for:**  
Village Hampshire  
234 S State St  
Hampshire, IL 60140  
Phone: 847-683-2181

**Prepared by:**  
Luke Burbach  
TRUCK COUNTRY  
2222 WEST RYAN ROAD  
OAK CREEK, WI 53154  
Phone: 414-416-9553

## S P E C ' D A L T E R N A T I V E S



Prepared for:  
 Village Hampshire  
 234 S State St  
 Hampshire, IL 60140  
 Phone: 847-683-2181

Prepared by:  
 Luke Burbach  
 TRUCK COUNTRY  
 2222 WEST RYAN ROAD  
 OAK CREEK, WI 53154  
 Phone: 414-416-9553

## S P E C I F I C A T I O N   P R O P O S A L

Data Code	Description	Weight Front	Weight Rear
<b>Price Level</b>			
PRL-19D	SD PRL-19D (EFF:01/15/19)		
<b>Data Version</b>			
DRL-014	SPECPRO21 DATA RELEASE VER 014		
<b>Vehicle Configuration</b>			
001-176	108SD CONVENTIONAL CHASSIS	6,829	3,748
004-220	2020 MODEL YEAR SPECIFIED		
002-004	SET BACK AXLE - TRUCK		
019-002	STRAIGHT TRUCK PROVISION		
003-001	LH PRIMARY STEERING LOCATION		
<b>General Service</b>			
AA1-002	TRUCK CONFIGURATION		
AA6-002	DOMICILED, USA (EXCLUDING CALIFORNIA AND CARB OPT-IN STATES)		
A85-010	UTILITY/REPAIR/MAINTENANCE SERVICE		
A84-1GM	GOVERNMENT BUSINESS SEGMENT		
AA4-010	DIRT/SAND/ROCK COMMODITY		
AA5-002	TERRAIN/DUTY: 100% (ALL) OF THE TIME, IN TRANSIT, IS SPENT ON PAVED ROADS		
AB1-008	MAXIMUM 8% EXPECTED GRADE		
AB5-001	SMOOTH CONCRETE OR ASPHALT PAVEMENT - MOST SEVERE IN-TRANSIT (BETWEEN SITES) ROAD SURFACE		
995-1A0	FREIGHTLINER SD VOCATIONAL WARRANTY		
A66-99D	EXPECTED FRONT AXLE(S) LOAD : 20000.0 lbs		
A68-99D	EXPECTED REAR DRIVE AXLE(S) LOAD : 23000.0 lbs		
A63-99D	EXPECTED GROSS VEHICLE WEIGHT CAPACITY : 43000.0 lbs		
<b>Truck Service</b>			
AA3-018	FRONT PLOW/END DUMP BODY		
AF3-142	MONROE TRUCK EQUIPMENT		



Prepared for:  
 Village Hampshire  
 234 S State St  
 Hampshire, IL 60140  
 Phone: 847-683-2181

Prepared by:  
 Luke Burbach  
 TRUCK COUNTRY  
 2222 WEST RYAN ROAD  
 OAK CREEK, WI 53154  
 Phone: 414-416-9553

Data Code	Description	Weight Front	Weight Rear
<b>Engine</b>			
101-22R	CUM L9 330 HP @ 2000 RPM, 2200 GOV RPM, 1000 LB/FT @ 1400 RPM		
<b>Electronic Parameters</b>			
79A-075	75 MPH ROAD SPEED LIMIT		
79B-000	CRUISE CONTROL SPEED LIMIT SAME AS ROAD SPEED LIMIT		
79K-006	PTO MODE ENGINE RPM LIMIT - 1000 RPM		
79M-001	PTO MODE BRAKE OVERRIDE - SERVICE BRAKE APPLIED		
79P-004	PTO RPM WITH CRUISE SET SWITCH - 900 RPM		
79Q-004	PTO RPM WITH CRUISE RESUME SWITCH - 900 RPM		
79S-001	PTO MODE CANCEL VEHICLE SPEED - 5 MPH		
79U-007	PTO GOVERNOR RAMP RATE - 250 RPM PER SECOND		
80G-002	PTO MINIMUM RPM - 700		
80J-002	REGEN INHIBIT SPEED THRESHOLD - 5 MPH		
<b>Engine Equipment</b>			
99C-017	2016 ONBOARD DIAGNOSTICS/2010 EPA/CARB/FINAL GHG17 CONFIGURATION		
99D-010	NO 2008 CARB EMISSION CERTIFICATION		
13E-001	STANDARD OIL PAN		
105-001	ENGINE MOUNTED OIL CHECK AND FILL		
014-1C5	SIDE OF HOOD AIR INTAKE WITH FIREWALL MOUNTED DONALDSON AIR CLEANER AND INSIDE/OUTSIDE AIR WITH SNOW DOOR	10	
124-1D7	DR 12V 160 AMP 28-SI QUADRAMOUNT PAD ALTERNATOR WITH REMOTE BATTERY VOLT SENSE		
292-208	(2) DTNA GENUINE, FLOODED STARTING, MIN 2250CCA, 390RC, THREADED STUD BATTERIES		
290-017	BATTERY BOX FRAME MOUNTED		
281-001	STANDARD BATTERY JUMPERS		
282-001	SINGLE BATTERY BOX FRAME MOUNTED LH SIDE UNDER CAB		
291-017	WIRE GROUND RETURN FOR BATTERY CABLES WITH ADDITIONAL FRAME GROUND RETURN		
289-001	NON-POLISHED BATTERY BOX COVER		
87P-001	CAB AUXILIARY POWER CABLE	5	



Prepared for:  
 Village Hampshire  
 234 S State St  
 Hampshire, IL 60140  
 Phone: 847-683-2181

Prepared by:  
 Luke Burbach  
 TRUCK COUNTRY  
 2222 WEST RYAN ROAD  
 OAK CREEK, WI 53154  
 Phone: 414-416-9553

Data Code	Description	Weight Front	Weight Rear
293-058	POSITIVE LOAD DISCONNECT WITH CAB MOUNTED CONTROL SWITCH MOUNTED OUTBOARD DRIVER SEAT	8	
295-029	POSITIVE AND NEGATIVE POSTS FOR JUMPSTART LOCATED ON FRAME NEXT TO STARTER	2	
107-032	CUMMINS TURBOCHARGED 18.7 CFM AIR COMPRESSOR WITH INTERNAL SAFETY VALVE		
152-041	ELECTRONIC ENGINE INTEGRAL SHUTDOWN PROTECTION SYSTEM		
128-076	CUMMINS EXHAUST BRAKE INTEGRAL WITH VARIABLE GEOMETRY TURBO WITH ON/OFF DASH SWITCH	20	
016-1C2	RH OUTBOARD UNDER STEP MOUNTED HORIZONTAL AFTERTREATMENT SYSTEM ASSEMBLY WITH RH B-PILLAR MOUNTED VERTICAL TAILPIPE	30	25
28F-002	ENGINE AFTERTREATMENT DEVICE, AUTOMATIC OVER THE ROAD REGENERATION AND DASH MOUNTED REGENERATION REQUEST SWITCH		
239-038	11 FOOT 06 INCH (138 INCH+0/-5.9 INCH) EXHAUST SYSTEM HEIGHT		
237-1CR	RH CURVED VERTICAL TAILPIPE B-PILLAR MOUNTED ROUTED FROM STEP		
23U-001	6 GALLON DIESEL EXHAUST FLUID TANK	-35	-10
30N-003	100 PERCENT DIESEL EXHAUST FLUID FILL		
23Y-001	STANDARD DIESEL EXHAUST FLUID PUMP MOUNTING		
43X-002	LH MEDIUM DUTY STANDARD DIESEL EXHAUST FLUID TANK LOCATION		
43Y-001	STANDARD DIESEL EXHAUST FLUID TANK CAP		
242-011	ALUMINUM AFTERTREATMENT DEVICE/MUFFLER/TAILOPIPE SHIELD(S)		
273-018	HORTON DRIVEMASTER ADVANTAGE ON/OFF FAN DRIVE		
276-001	AUTOMATIC FAN CONTROL WITHOUT DASH SWITCH, NON ENGINE MOUNTED		
110-003	CUMMINS SPIN ON FUEL FILTER		
118-008	COMBINATION FULL FLOW/BYPASS OIL FILTER		
266-104	1115 SQUARE INCH ALUMINUM RADIATOR		
103-039	ANTIFREEZE TO -34F, OAT (NITRITE AND SILICATE FREE) EXTENDED LIFE COOLANT		
171-007	GATES BLUE STRIPE COOLANT HOSES OR EQUIVALENT		





Prepared for:  
 Village Hampshire  
 234 S State St  
 Hampshire, IL 60140  
 Phone: 847-683-2181

Prepared by:  
 Luke Burbach  
 TRUCK COUNTRY  
 2222 WEST RYAN ROAD  
 OAK CREEK, WI 53154  
 Phone: 414-416-9553

Data Code	Description	Weight Front	Weight Rear
172-001	CONSTANT TENSION HOSE CLAMPS FOR COOLANT HOSES		
270-016	RADIATOR DRAIN VALVE		
360-013	1350 ADAPTER FLANGE FOR FRONT PTO PROVISION	20	
138-011	PHILLIPS-TEMRO 1000 WATT/115 VOLT BLOCK HEATER	4	
140-053	BLACK PLASTIC ENGINE HEATER RECEPTACLE MOUNTED UNDER LH DOOR		
132-004	ELECTRIC GRID AIR INTAKE WARMER		
155-058	DELCO 12V 38MT HD STARTER WITH INTEGRATED MAGNETIC SWITCH		

#### Transmission

342-582	ALLISON 3000 RDS AUTOMATIC TRANSMISSION WITH PTO PROVISION		
---------	--	--	--

#### Transmission Equipment

343-339	ALLISON VOCATIONAL PACKAGE 223 - AVAILABLE ON 3000/4000 PRODUCT FAMILIES WITH VOCATIONAL MODELS RDS, HS, MH AND TRV		
84B-012	ALLISON VOCATIONAL RATING FOR ON/OFF HIGHWAY APPLICATIONS AVAILABLE WITH ALL PRODUCT FAMILIES		
84C-023	PRIMARY MODE GEARS, LOWEST GEAR 1, START GEAR 1, HIGHEST GEAR 6, AVAILABLE FOR 3000/4000 PRODUCT FAMILIES ONLY		
84D-023	SECONDARY MODE GEARS, LOWEST GEAR 1, START GEAR 1, HIGHEST GEAR 6, AVAILABLE FOR 3000/4000 PRODUCT FAMILIES ONLY		
84E-000	PRIMARY SHIFT SCHEDULE RECOMMENDED BY DTNA AND ALLISON, THIS DEFINED BY ENGINE AND VOCATIONAL USAGE		
84F-000	SECONDARY SHIFT SCHEDULE RECOMMENDED BY DTNA AND ALLISON, THIS DEFINED BY ENGINE AND VOCATIONAL USAGE		
84G-000	PRIMARY SHIFT SPEED RECOMMENDED BY DTNA AND ALLISON, THIS DEFINED BY ENGINE AND VOCATIONAL USAGE		
84H-000	SECONDARY SHIFT SPEED RECOMMENDED BY DTNA AND ALLISON, THIS DEFINED BY ENGINE AND VOCATIONAL USAGE		
84N-200	FUEL SENSE 2.0 DISABLED - MAXIMUM PERFORMANCE - TABLE BASED		
84U-000	DRIVER SWITCH INPUT - DEFAULT - NO SWITCHES		



Prepared for:  
 Village Hampshire  
 234 S State St  
 Hampshire, IL 60140  
 Phone: 847-683-2181

Prepared by:  
 Luke Burbach  
 TRUCK COUNTRY  
 2222 WEST RYAN ROAD  
 OAK CREEK, WI 53154  
 Phone: 414-416-9553

Data Code	Description	Weight Front	Weight Rear
84V-001	DIRECTION CHANGE ENABLED WITH MULTIPLEXED SERVICE BRAKES - ALLISON 5TH GEN TRANSMISSIONS		
353-023	VEHICLE INTERFACE WIRING CONNECTOR WITHOUT BLUNT CUTS, AT END OF FRAME		
34C-001	ELECTRONIC TRANSMISSION CUSTOMER ACCESS CONNECTOR FIREWALL MOUNTED		
341-018	MAGNETIC PLUGS, ENGINE DRAIN, TRANSMISSION DRAIN, AXLE(S) FILL AND DRAIN		
345-037	ELECTRONIC CONTROL T-HANDLE SHIFT LEVER, DASH MOUNTED		
97G-004	TRANSMISSION PROGNOSTICS - ENABLED 2013		
370-015	WATER TO OIL TRANSMISSION COOLER, IN RADIATOR END TANK		
346-003	TRANSMISSION OIL CHECK AND FILL WITH ELECTRONIC OIL LEVEL CHECK		
35T-001	SYNTHETIC TRANSMISSION FLUID (TES-295 COMPLIANT)		

### Front Axle and Equipment

400-1BB	DETROIT DA-F-20.0-5 20,000# FL1 71.0 KPI/3.74 DROP SINGLE FRONT AXLE	190	
402-030	MERITOR 16.5X6 Q+ CAST SPIDER CAM FRONT BRAKES, DOUBLE ANCHOR, FABRICATED SHOES	10	
403-002	NON-ASBESTOS FRONT BRAKE LINING		
419-023	CONMET CAST IRON FRONT BRAKE DRUMS		
427-001	FRONT BRAKE DUST SHIELDS	5	
409-006	FRONT OIL SEALS		
408-016	STEMCO ALUMINUM VENTED FRONT HUB CAPS WITH WINDOW AND CENTER AND SIDE PLUGS - OIL		
416-022	STANDARD SPINDLE NUTS FOR ALL AXLES		
405-002	MERITOR AUTOMATIC FRONT SLACK ADJUSTERS		
406-001	STANDARD KING PIN BUSHINGS		
536-055	TRW THP-60 POWER STEERING WITH RCH45 AUXILIARY GEAR	130	
539-003	POWER STEERING PUMP		
534-003	4 QUART POWER STEERING RESERVOIR		
533-001	OIL/AIR POWER STEERING COOLER		
40T-002	SYNTHETIC 75W-90 FRONT AXLE LUBE		

### Front Suspension



Prepared for:  
 Village Hampshire  
 234 S State St  
 Hampshire, IL 60140  
 Phone: 847-683-2181

Prepared by:  
 Luke Burbach  
 TRUCK COUNTRY  
 2222 WEST RYAN ROAD  
 OAK CREEK, WI 53154  
 Phone: 414-416-9553

Data Code	Description	Weight Front	Weight Rear
620-006	20,000# FLAT LEAF FRONT SUSPENSION	310	
619-004	GRAPHITE BRONZE BUSHINGS WITH SEALS - FRONT SUSPENSION		
62G-998	NO FRONT SUSPENSION OPTIONS		
62H-014	LEFT AND RIGHT FRONT SUSPENSION REAR SHACKLE PINS WITH ZERK FITTINGS OUTBOARD		
410-001	FRONT SHOCK ABSORBERS		
<b>Rear Axle and Equipment</b>			
420-051	RS-23-160 23,000# R-SERIES SINGLE REAR AXLE		180
421-563	5.63 REAR AXLE RATIO		
424-001	IRON REAR AXLE CARRIER WITH STANDARD AXLE HOUSING		
386-046	SPL140HD DANA SPICER MAIN DRIVELINE WITH HALF ROUND YOKES	5	5
452-001	DRIVER CONTROLLED TRACTION DIFFERENTIAL - SINGLE REAR AXLE		20
878-018	(1) DRIVER CONTROLLED DIFFERENTIAL LOCK REAR VALVE FOR SINGLE DRIVE AXLE		
87B-004	BLINKING LAMP WITH EACH MODE SWITCH, DIFFERENTIAL UNLOCK WITH IGNITION OFF, ACTIVE <5 MPH		
423-033	MERITOR 16.5X7 Q+ CAST SPIDER HEAVY DUTY CAM REAR BRAKES, DOUBLE ANCHOR, FABRICATED SHOES		
433-002	NON-ASBESTOS REAR BRAKE LINING		
434-011	BRAKE CAMS AND CHAMBERS ON FORWARD SIDE OF DRIVE AXLE(S)		
* 451-023	CONMET CAST IRON REAR BRAKE DRUMS MUST BE MACHINE BALANCED		
425-002	REAR BRAKE DUST SHIELDS		5
440-006	REAR OIL SEALS		
426-100	WABCO TRISTOP D LONGSTROKE 1-DRIVE AXLE SPRING PARKING CHAMBERS		
428-002	MERITOR AUTOMATIC REAR SLACK ADJUSTERS		
41T-002	SYNTHETIC 75W-90 REAR AXLE LUBE		
42T-001	STANDARD REAR AXLE BREATHER(S)		
<b>Rear Suspension</b>			
622-1DC	26,000# FLAT LEAF SPRING REAR SUSPENSION WITH HELPER AND RADIUS ROD		100
621-001	SPRING SUSPENSION - NO AXLE SPACERS		



Prepared for:  
 Village Hampshire  
 234 S State St  
 Hampshire, IL 60140  
 Phone: 847-683-2181

Prepared by:  
 Luke Burbach  
 TRUCK COUNTRY  
 2222 WEST RYAN ROAD  
 OAK CREEK, WI 53154  
 Phone: 414-416-9553

Data Code	Description	Weight Front	Weight Rear
431-001	STANDARD AXLE SEATS IN AXLE CLAMP GROUP		
623-005	FORE/AFT CONTROL RODS		
<b>Brake System</b>			
490-100	WABCO 4S/4M ABS		
871-001	REINFORCED NYLON, FABRIC BRAID AND WIRE BRAID CHASSIS AIR LINES		
904-001	FIBER BRAID PARKING BRAKE HOSE		
412-001	STANDARD BRAKE SYSTEM VALVES		
46D-002	STANDARD AIR SYSTEM PRESSURE PROTECTION SYSTEM		
413-002	STD U.S. FRONT BRAKE VALVE		
432-003	RELAY VALVE WITH 5-8 PSI CRACK PRESSURE, NO REAR PROPORTIONING VALVE		
480-009	BW AD-9 BRAKE LINE AIR DRYER WITH HEATER	20	
479-003	AIR DRYER MOUNTED INBOARD ON LH RAIL		
460-001	STEEL AIR BRAKE RESERVOIRS		
607-001	CLEAR FRAME RAILS FROM BACK OF CAB TO FRONT REAR SUSPENSION BRACKET, BOTH RAILS OUTBOARD		
477-008	BW DV-2 AUTO DRAIN VALVE WITH HEATER - WET TANK		
<b>Trailer Connections</b>			
296-027	PRIMARY CONNECTOR/RECEPTACLE WIRED FOR COMBINATION STOP/TURN, CENTER PIN POWERED THROUGH IGNITION WITH STOP SIGNAL PREWIRE PACKAGE		
297-001	SAE J560 7-WAY PRIMARY TRAILER CABLE RECEPTACLE MOUNTED END OF FRAME	5	5
335-004	UPGRADED CHASSIS MULTIPLEXING UNIT		
<b>Wheelbase &amp; Frame</b>			
545-407	4075MM (160 INCH) WHEELBASE		
546-102	7/16X3-9/16X11-1/8 INCH STEEL FRAME (11.11MMX282.6MM/0.437X11.13 INCH) 120KSI	110	170
548-803	BODY COMPANY INSTALLED ADDITIONAL FRONT FRAME REINFORCEMENT FOR SNOW PLOW		
552-030	1600MM (63 INCH) REAR FRAME OVERHANG		
55W-006	FRAME OVERHANG RANGE: 61 INCH TO 70 INCH		
AC8-99D	CALC'D BACK OF CAB TO REAR SUSP C/L (CA) : 94.85 in		



Prepared for:  
 Village Hampshire  
 234 S State St  
 Hampshire, IL 60140  
 Phone: 847-683-2181

Prepared by:  
 Luke Burbach  
 TRUCK COUNTRY  
 2222 WEST RYAN ROAD  
 OAK CREEK, WI 53154  
 Phone: 414-416-9553

Data Code	Description	Weight Front	Weight Rear
AE8-99D	CALCULATED EFFECTIVE BACK OF CAB TO REAR SUSPENSION C/L (CA) : 91.85 in		
AE4-99D	CALC'D FRAME LENGTH - OVERALL : 262.76		
FSS-0LH	CALCULATED FRAME SPACE LH SIDE : 10.92 in		
FSS-0RH	CALCULATED FRAME SPACE RH SIDE : 165.18 in		
AM6-99D	CALC'D SPACE AVAILABLE FOR DECKPLATE : 94.45 in		
553-001	SQUARE END OF FRAME		
550-001	FRONT CLOSING CROSSMEMBER		
559-003	LIGHTWEIGHT HEAVY DUTY ALUMINUM ENGINE CROSSMEMBER	-12	
562-001	STANDARD MIDSHIP #1 CROSSMEMBER(S)		
572-001	STANDARD REARMOST CROSSMEMBER		
565-001	STANDARD SUSPENSION CROSSMEMBER		
<b>Chassis Equipment</b>			
556-1E5	14 INCH PAINTED STEEL BUMPER		
558-001	FRONT TOW HOOKS - FRAME MOUNTED	15	
574-001	BUMPER MOUNTING FOR SINGLE LICENSE PLATE		
551-007	GRADE 8 THREADED HEX HEADED FRAME FASTENERS		
<b>Fuel Tanks</b>			
204-215	50 GALLON/189 LITER SHORT RECTANGULAR ALUMINUM FUEL TANK - LH	-10	
218-005	RECTANGULAR FUEL TANK(S)		
215-005	PLAIN ALUMINUM/PAINTED STEEL FUEL/HYDRAULIC TANK(S) WITH PAINTED BANDS		
212-008	FUEL TANK(S) AFT	-35	35
664-001	PLAIN STEP FINISH		
205-001	FUEL TANK CAP(S)		
122-1H8	DAVCO 245 FUEL/WATER SEPARATOR WITH 12 VOLT HEAT AND WATER IN FUEL SENSOR	5	
216-020	EQUIFLO INBOARD FUEL SYSTEM		
11F-998	NO NATURAL GAS VEHICLE FUEL TANK VENT LINE/STACK		
202-016	HIGH TEMPERATURE REINFORCED NYLON FUEL LINE		
<b>Tires</b>			
093-1PB	CONTINENTAL CITY SERVICE HA3 315/80R22.5 20 PLY RADIAL FRONT TIRES	100	



Prepared for:  
 Village Hampshire  
 234 S State St  
 Hampshire, IL 60140  
 Phone: 847-683-2181

Prepared by:  
 Luke Burbach  
 TRUCK COUNTRY  
 2222 WEST RYAN ROAD  
 OAK CREEK, WI 53154  
 Phone: 414-416-9553

Data Code	Description	Weight Front	Weight Rear
094-1RC	CONTINENTAL HDL2 11R22.5 16 PLY RADIAL REAR TIRES		56
<b>Hubs</b>			
418-060	CONMET PRESET PLUS PREMIUM IRON FRONT HUBS		
450-060	CONMET PRESET PLUS PREMIUM IRON REAR HUBS		
<b>Wheels</b>			
502-433	ACCURIDE 29039 22.5X9.00 10-HUB PILOT 5.25 INSET 5-HAND STEEL DISC FRONT WHEELS	66	
505-428	ACCURIDE 28828 22.5X8.25 10-HUB PILOT 2-HAND HD STEEL DISC REAR WHEELS		52
<b>Cab Exterior</b>			
829-1A5	108 INCH BBC FLAT ROOF ALUMINUM CONVENTIONAL CAB		
650-008	AIR CAB MOUNTING		
648-002	NONREMOVABLE BUGSCREEN MOUNTED BEHIND GRILLE		
667-037	SHORT FENDER WITH MUDFLAP		
754-017	BOLT-ON MOLDED FLEXIBLE FENDER EXTENSIONS	10	
678-001	LH AND RH GRAB HANDLES		
646-041	STATIONARY BLACK GRILLE		
65X-004	BLACK HOOD MOUNTED AIR INTAKE GRILLE		
644-004	FIBERGLASS HOOD		
727-1AH	SINGLE 14 INCH ROUND POLISHED AIR HORN ROOF MOUNTED		
726-001	SINGLE ELECTRIC HORN		
728-001	SINGLE HORN SHIELD		
657-001	DOOR LOCKS AND IGNITION SWITCH KEYED THE SAME		
575-001	REAR LICENSE PLATE MOUNT END OF FRAME		
327-012	SWITCH, INDICATOR LIGHT AND WIRING FOR (2) CUSTOMER FURNISHED BEACONS		
312-068	HALOGEN COMPOSITE HEADLAMPS WITH BLACK BEZELS		
302-001	(5) AMBER MARKER LIGHTS		
294-001	INTEGRAL STOP/TAIL/BACKUP LIGHTS		
300-015	STANDARD FRONT TURN SIGNAL LAMPS		
744-1BG	DUAL WEST COAST MOLDED-IN COLOR HEATED MIRRORS		
797-001	DOOR MOUNTED MIRRORS		



Prepared for:  
 Village Hampshire  
 234 S State St  
 Hampshire, IL 60140  
 Phone: 847-683-2181

Prepared by:  
 Luke Burbach  
 TRUCK COUNTRY  
 2222 WEST RYAN ROAD  
 OAK CREEK, WI 53154  
 Phone: 414-416-9553

Data Code	Description	Weight Front	Weight Rear
796-001	102 INCH EQUIPMENT WIDTH		
743-1AP	LH AND RH 8 INCH MOLDED-IN COLOR CONVEX MIRRORS MOUNTED UNDER PRIMARY MIRRORS		
729-001	STANDARD SIDE/REAR REFLECTORS		
677-055	RH AFTERTREATMENT SYSTEM CAB ACCESS WITH POLISHED DIAMOND PLATE COVER		
768-043	63X14 INCH TINTED REAR WINDOW		
661-004	TINTED DOOR GLASS LH AND RH WITH TINTED OPERATING WING WINDOWS		
654-027	RH AND LH ELECTRIC POWERED WINDOWS, PASSENGER SWITCHES ON DOOR(S)	4	
769-002	LOWER RH DOOR WINDOW WITH FRESNEL LENS	7	
663-029	1-PIECE TINTED CURVED BONDED WINDSHIELD WITH HEATED WIPER BLADE PARK AREAS		
659-006	8 LITER WINDSHIELD WASHER RESERVOIR, CAB MOUNTED, WITH FLUID LEVEL INDICATOR		

#### Cab Interior

707-1AK	OPAL GRAY VINYL INTERIOR		
706-013	MOLDED PLASTIC DOOR PANEL		
708-013	MOLDED PLASTIC DOOR PANEL		
772-006	BLACK MATS WITH SINGLE INSULATION		
785-001	DASH MOUNTED ASH TRAYS AND LIGHTER		
691-008	FORWARD ROOF MOUNTED CONSOLE WITH UPPER STORAGE COMPARTMENTS WITHOUT NETTING		
694-010	IN DASH STORAGE BIN		
742-007	(2) CUP HOLDERS LH AND RH DASH		
680-006	GRAY/CHARCOAL FLAT DASH		
860-004	SMART SWITCH EXPANSION MODULE		
700-002	HEATER, DEFROSTER AND AIR CONDITIONER		
701-008	STANDARD HVAC DUCTING WITH SNOW SHIELD FOR FRESH AIR INTAKE		
703-005	MAIN HVAC CONTROLS WITH RECIRCULATION SWITCH		
170-019	STANDARD HEATER PLUMBING WITH BALL SHUTOFF VALVES		
130-041	VALEO HEAVY DUTY A/C REFRIGERANT COMPRESSOR		
702-002	BINARY CONTROL, R-134A		
739-033	STANDARD INSULATION		



Prepared for:  
 Village Hampshire  
 234 S State St  
 Hampshire, IL 60140  
 Phone: 847-683-2181

Prepared by:  
 Luke Burbach  
 TRUCK COUNTRY  
 2222 WEST RYAN ROAD  
 OAK CREEK, WI 53154  
 Phone: 414-416-9553

Data Code	Description	Weight Front	Weight Rear
285-027	SOLID-STATE CIRCUIT PROTECTION AND FUSES WITH SPARE FUSE KIT		
280-007	12V NEGATIVE GROUND ELECTRICAL SYSTEM		
324-011	DOMED DOOR ACTIVATED LH AND RH, DUAL READING LIGHTS, FORWARD CAB ROOF		
655-005	LH AND RH ELECTRIC DOOR LOCKS		
284-023	(1) 12 VOLT POWER SUPPLY IN DASH		
756-1D9	PREMIUM HIGH BACK AIR SUSPENSION DRIVER SEAT WITH 3 CHAMBER AIR LUMBAR, INTEGRATED CUSHION EXTENSION, FORWARD AND REAR CUSHION TILT, ADJUSTABLE SHOCK ABSORBER	70	
760-1DC	BASIC HIGH BACK NON SUSPENSION PASSENGER SEAT		
759-007	DUAL DRIVER SEAT ARMRESTS, NO PASSENGER SEAT ARMRESTS	4	
711-004	LH AND RH INTEGRAL DOOR PANEL ARMRESTS		
758-022	BLACK MORDURA CLOTH DRIVER SEAT COVER		
761-023	BLACK MORDURA CLOTH PASSENGER SEAT COVER		
763-101	BLACK SEAT BELTS		
532-002	ADJUSTABLE TILT AND TELESCOPING STEERING COLUMN	10	
540-015	4-SPOKE 18 INCH (450MM) STEERING WHEEL		
765-002	DRIVER AND PASSENGER INTERIOR SUN VISORS		

### Instruments & Controls

732-004	GRAY DRIVER INSTRUMENT PANEL		
734-004	GRAY CENTER INSTRUMENT PANEL		
870-001	BLACK GAUGE BEZELS		
486-001	LOW AIR PRESSURE INDICATOR LIGHT AND AUDIBLE ALARM		
840-002	2 INCH PRIMARY AND SECONDARY AIR PRESSURE GAUGES		
198-003	DASH MOUNTED AIR RESTRICTION INDICATOR WITH GRADUATIONS		
721-001	97 DB BACKUP ALARM		3
149-017	ELECTRONIC CRUISE CONTROL WITH SWITCHES ON AUXILIARY GAUGE PANEL (B DASH PANEL)		
156-007	KEY OPERATED IGNITION SWITCH AND INTEGRAL START POSITION; 4 POSITION OFF/RUN/START/ACCESSORY		





Prepared for:  
 Village Hampshire  
 234 S State St  
 Hampshire, IL 60140  
 Phone: 847-683-2181

Prepared by:  
 Luke Burbach  
 TRUCK COUNTRY  
 2222 WEST RYAN ROAD  
 OAK CREEK, WI 53154  
 Phone: 414-416-9553

Data Code	Description	Weight Front	Weight Rear
811-042	ICU3S, 132X48 DISPLAY WITH DIAGNOSTICS, 28 LED WARNING LAMPS AND DATA LINKED		
160-038	HEAVY DUTY ONBOARD DIAGNOSTICS INTERFACE CONNECTOR LOCATED BELOW LH DASH		
844-001	2 INCH ELECTRIC FUEL GAUGE		
148-003	PROGRAMMABLE RPM CONTROL - ELECTRONIC ENGINE		
856-001	ELECTRICAL ENGINE COOLANT TEMPERATURE GAUGE		
864-001	2 INCH TRANSMISSION OIL TEMPERATURE GAUGE		
830-017	ENGINE AND TRIP HOUR METERS INTEGRAL WITHIN DRIVER DISPLAY		
852-002	ELECTRIC ENGINE OIL PRESSURE GAUGE		
679-001	OVERHEAD INSTRUMENT PANEL		
746-114	AM/FM/WB WORLD TUNER RADIO WITH AUXILIARY INPUT, J1939	10	
747-001	DASH MOUNTED RADIO		
750-002	(2) RADIO SPEAKERS IN CAB		
753-001	AM/FM ANTENNA MOUNTED ON FORWARD LH ROOF		
810-027	ELECTRONIC MPH SPEEDOMETER WITH SECONDARY KPH SCALE, WITHOUT ODOMETER		
817-008	STANDARD VEHICLE SPEED SENSOR WITH ADDITIONAL SIGNAL FOR CUSTOMER USE LOCATED BETWEEN DRIVER AND PASSENGER SEATS		
812-001	ELECTRONIC 3000 RPM TACHOMETER		
162-002	IGNITION SWITCH CONTROLLED ENGINE STOP		
* 329-083	SIX ON/OFF ROCKER SWITCHES IN THE DASH WITH INDICATOR LIGHTS; FOUR WIRE TO CHASSIS AT BACK OF CAB, TWO UNWIRED, LABEL ALL OPT		
	ALL PLACED NEXT TO EACH OTHER IN DASH AND ALL RAN TO BOC		
836-015	DIGITAL VOLTAGE DISPLAY INTEGRAL WITH DRIVER DISPLAY		
660-001	SINGLE ELECTRIC WINDSHIELD WIPER MOTOR WITH DELAY AND ARCTIC TYPE BLADES		
304-039	MARKER LIGHT SWITCH INTEGRAL WITH HEADLIGHT SWITCH AND DUAL CONNECTORS AND SWITCH FOR CUSTOMER FURNISHED SNOW PLOW LIGHTS, LOW BEAMS OFF WITH HIGH BEAMS		



Prepared for:  
 Village Hampshire  
 234 S State St  
 Hampshire, IL 60140  
 Phone: 847-683-2181

Prepared by:  
 Luke Burbach  
 TRUCK COUNTRY  
 2222 WEST RYAN ROAD  
 OAK CREEK, WI 53154  
 Phone: 414-416-9553

Data Code	Description	Weight Front	Weight Rear
882-009	ONE VALVE PARKING BRAKE SYSTEM WITH WARNING INDICATOR		
299-013	SELF CANCELING TURN SIGNAL SWITCH WITH DIMMER, WASHER/WIPER AND HAZARD IN HANDLE		
298-039	INTEGRAL ELECTRONIC TURN SIGNAL FLASHER WITH HAZARD LAMPS OVERRIDING STOP LAMPS		

**Design**

065-000 PAINT: ONE SOLID COLOR

**Color**

980-1HB	CAB COLOR A: N3019EA VICTORY RED ELITE SS
N 981-6KK	CAB COLOR B: L6389EB OMAHA ORANGE ELITE BC
986-020	BLACK, HIGH SOLIDS POLYURETHANE CHASSIS PAINT
962-974	POWDER GRAY (N0020EA) FRONT WHEELS/RIMS (PKGGRY21, G, PG1)
966-974	POWDER GRAY (N0020EA) REAR WHEELS/RIMS (PKGGRY21, G, PG1)
964-020	STANDARD BLACK BUMPER PAINT
963-003	STANDARD E COAT/UNDERCOATING

**Certification / Compliance**

996-001 U.S. FMVSS CERTIFICATION, EXCEPT SALES CABS AND GLIDER KITS

**Raw Performance Data**

AE4-99D	CALC'D FRAME LENGTH - OVERALL : 262.76
AE8-99D	CALCULATED EFFECTIVE BACK OF CAB TO REAR SUSPENSION C/L (CA) : 91.85 in
AM6-99D	CALC'D SPACE AVAILABLE FOR DECKPLATE : 94.45 in

**Sales Programs**

NO SALES PROGRAMS HAVE BEEN SELECTED

**TOTAL VEHICLE SUMMARY**

**Weight Summary**

Weight	Weight	Total
--------	--------	-------



**Prepared for:**  
Village Hampshire  
234 S State St  
Hampshire, IL 60140  
Phone: 847-683-2181

**Prepared by:**  
Luke Burbach  
TRUCK COUNTRY  
2222 WEST RYAN ROAD  
OAK CREEK, WI 53154  
Phone: 414-416-9553

	<b>Front</b>	<b>Rear</b>	<b>Weight</b>
Factory Weight <sup>+</sup>	7922 lbs	4394 lbs	12316 lbs
<hr/>			
Total Weight <sup>+</sup>	7922 lbs	4394 lbs	12316 lbs

### Extended Warranty

WAG-010 TOWING: 1 YEAR/UNLIMITED MILES/KM EXTENDED TOWING  
COVERAGE \$550 CAP FEX APPLIES

(+) Weights shown are estimates only.  
If weight is critical, contact Customer Application Engineering.



Prepared for:  
 Village Hampshire  
 234 S State St  
 Hampshire, IL 60140  
 Phone: 847-683-2181

Prepared by:  
 Luke Burbach  
 TRUCK COUNTRY  
 2222 WEST RYAN ROAD  
 OAK CREEK, WI 53154  
 Phone: 414-416-9553

## CONDENSED SPECIFICATION PROPOSAL

Data Code	Description	Weight Front	Weight Rear
<b>Vehicle Configuration</b>			
001-176	108SD CONVENTIONAL CHASSIS	6,829	3,748
002-004	SET BACK AXLE - TRUCK		
<b>Engine</b>			
101-22R	CUM L9 330 HP @ 2000 RPM, 2200 GOV RPM, 1000 LB/FT @ 1400 RPM		
<b>Engine Equipment</b>			
128-076	CUMMINS EXHAUST BRAKE INTEGRAL WITH VARIABLE GEOMETRY TURBO WITH ON/OFF DASH SWITCH	20	
016-1C2	RH OUTBOARD UNDER STEP MOUNTED HORIZONTAL AFTERTREATMENT SYSTEM ASSEMBLY WITH RH B-PILLAR MOUNTED VERTICAL TAILPIPE	30	25
<b>Transmission</b>			
342-582	ALLISON 3000 RDS AUTOMATIC TRANSMISSION WITH PTO PROVISION		
<b>Front Axle and Equipment</b>			
400-1BB	DETROIT DA-F-20.0-5 20,000# FL1 71.0 KPI/3.74 DROP SINGLE FRONT AXLE	190	
<b>Front Suspension</b>			
620-006	20,000# FLAT LEAF FRONT SUSPENSION	310	
<b>Rear Axle and Equipment</b>			
420-051	RS-23-160 23,000# R-SERIES SINGLE REAR AXLE		180
421-563	5.63 REAR AXLE RATIO		
<b>Rear Suspension</b>			
622-1DC	26,000# FLAT LEAF SPRING REAR SUSPENSION WITH HELPER AND RADIUS ROD		100
<b>Wheelbase &amp; Frame</b>			
545-407	4075MM (160 INCH) WHEELBASE		
546-102	7/16X3-9/16X11-1/8 INCH STEEL FRAME (11.11MMX282.6MM/0.437X11.13 INCH) 120KSI	110	170
<b>Fuel Tanks</b>			
204-215	50 GALLON/189 LITER SHORT RECTANGULAR ALUMINUM FUEL TANK - LH	-10	
<b>Tires</b>			



Prepared for:  
 Village Hampshire  
 234 S State St  
 Hampshire, IL 60140  
 Phone: 847-683-2181

Prepared by:  
 Luke Burbach  
 TRUCK COUNTRY  
 2222 WEST RYAN ROAD  
 OAK CREEK, WI 53154  
 Phone: 414-416-9553

Data Code	Description	Weight Front	Weight Rear
093-1PB	CONTINENTAL CITY SERVICE HA3 315/80R22.5 20 PLY RADIAL FRONT TIRES	100	
094-1RC	CONTINENTAL HDL2 11R22.5 16 PLY RADIAL REAR TIRES		56

**Wheels**

502-433	ACCURIDE 29039 22.5X9.00 10-HUB PILOT 5.25 INSET 5-HAND STEEL DISC FRONT WHEELS	66	
505-428	ACCURIDE 28828 22.5X8.25 10-HUB PILOT 2-HAND HD STEEL DISC REAR WHEELS		52

**Cab Exterior**

829-1A5	108 INCH BBC FLAT ROOF ALUMINUM CONVENTIONAL CAB
---------	--

**Color**

980-1HB	CAB COLOR A: N3019EA VICTORY RED ELITE SS
986-020	BLACK, HIGH SOLIDS POLYURETHANE CHASSIS PAINT

**Weight Summary**

	Weight Front	Weight Rear	Total Weight
Factory Weight <sup>+</sup>	7922 lbs	4394 lbs	12316 lbs
Total Weight <sup>+</sup>	7922 lbs	4394 lbs	12316 lbs

**ITEMS NOT INCLUDED IN ADJUSTED LIST PRICE**

**Other Factory Charges**

DELIVERY & ORDER PROCESSING CHARGE

(+) Weights shown are estimates only.  
 If weight is critical, contact Customer Application Engineering.



Prepared for:  
 Village Hampshire  
 234 S State St  
 Hampshire, IL 60140  
 Phone: 847-683-2181

Prepared by:  
 Luke Burbach  
 TRUCK COUNTRY  
 2222 WEST RYAN ROAD  
 OAK CREEK, WI 53154  
 Phone: 414-416-9553

## Q U O T A T I O N

### 108SD CONVENTIONAL CHASSIS

SET BACK AXLE - TRUCK CUM L9 330 HP @ 2000 RPM, 2200 GOV RPM, 1000 LB/FT @ 1400 RPM ALLISON 3000 RDS AUTOMATIC TRANSMISSION WITH PTO PROVISION RS-23-160 23,000# R-SERIES SINGLE REAR AXLE 26,000# FLAT LEAF SPRING REAR SUSPENSION WITH HELPER AND RADIUS ROD DETROIT DA-F-20.0-5 20,000# FL1 71.0 KPI/3.74 DROP SINGLE FRONT AXLE	20,000# FLAT LEAF FRONT SUSPENSION 108 INCH BBC FLAT ROOF ALUMINUM CONVENTIONAL CAB 4075MM (160 INCH) WHEELBASE 7/16X3-9/16X11-1/8 INCH STEEL FRAME (11.11MMX282.6MM/0.437X11.13 INCH) 120KSI 1600MM (63 INCH) REAR FRAME OVERHANG BODY COMPANY INSTALLED ADDITIONAL FRONT FRAME REINFORCEMENT FOR SNOW PLOW
--	---

		PER UNIT		TOTAL
VEHICLE PRICE	<b>TOTAL # OF UNITS (2)</b>	\$ 81,533	\$	163,066
EXTENDED WARRANTY		\$ 200	\$	400
DEALER INSTALLED OPTIONS		\$ 0	\$	0
<b>CUSTOMER PRICE BEFORE TAX</b>		<b>\$ 81,733</b>	<b>\$</b>	<b>163,466</b>

TAXES AND FEES				
FEDERAL EXCISE TAX (FET)	\$	(253)	\$	(506)
TAXES AND FEES	\$	0	\$	0
OTHER CHARGES	\$	0	\$	0

TRADE-IN				
<b>TRADE-IN ALLOWANCE</b>	\$	(0)	\$	(0)
<b>BALANCE DUE</b>	<b>(LOCAL CURRENCY)</b>	<b>\$ 81,480</b>	<b>\$</b>	<b>162,960</b>

**COMMENTS:**

Projected delivery on \_\_\_ / \_\_\_ / \_\_\_ provided the order is received before \_\_\_ / \_\_\_ / \_\_\_.

**APPROVAL:**

Please indicate your acceptance of this quotation by signing below:

Customer: X \_\_\_\_\_ Date: \_\_\_ / \_\_\_ / \_\_\_.

**Daimler Truck Financial**

Financing that works for you.

See your local dealer for a competitive quote from Daimler Truck Financial, or contact us at [Information@dtfoffers.com](mailto:Information@dtfoffers.com).  
 Daimler Truck Financial offers a variety of finance, lease and insurance solutions to fit your business needs. For more information about our products and services, visit our website at [www.daimler-truckfinancial.com](http://www.daimler-truckfinancial.com).



**Prepared for:**  
Village Hampshire  
234 S State St  
Hampshire, IL 60140  
Phone: 847-683-2181

**Prepared by:**  
Luke Burbach  
TRUCK COUNTRY  
2222 WEST RYAN ROAD  
OAK CREEK, WI 53154  
Phone: 414-416-9553





1385 Franklin Grove Rd  
 Dixon, IL 61021  
 815-284-3819 \* 815-284-8815 Fax  
 800-851-9664  
 www.bonnell.com \* info@bonnell.com

# Quote

Quote Number: 0133294  
 Quote Date: 4/15/2019



**Bill To:** 0002184  
 VILLAGE OF HAMPSHIRE  
 P O BOX 457  
 HAMPSHIRE, IL 60140-0457

**Ship To:** 01  
 VILLAGE OF HAMPSHIRE  
 234 S STATE ST  
 HAMPSHIRE, IL 60140

Phone: (847) 683-2181 Fax: (847) 683-4915 dstarrett@hampshireil.org

Phone:  
 Fax:

**Confirm To:** DAVID STARRETT Comment:

Customer P.O.	Ship VIA	F.O.B.	Terms	Quote Expiration
			Net 30 Days	5/15/2019

Ordered	Unit	Item Number	Each Price	Extended Price
2.00	EACH	<b>TRUCK PACKAGE</b>	71,950.00	143,900.00

APPLICATION: NEW SINGLE AXLE CAB AND CHASSIS WITH 85" CAB TO AXLE MEASUREMENT, FRONT FRAME EXTENSIONS, AUTOMATIC TRANSMISSION WITH LIVE PTO PROVISIONS, FACTORY PLOW LIGHT PLUG, FACTORY "GROUND SPEED CONNECTION POINT

THIS PACKAGE TO INCLUDE:

- 1- DURACCLASS 10' SL-316 304#4 STAINLESS STEEL DUMP BODY
- 1- CROSS MEMBERLESS
- 1- DURACCLASS 1821 DOUBLE ACTING UNDERBODY HOIST
- 1- 3/16" CORTEN LONGSILLS
- 1- 18" CAB SHIELD
- 1- 3/16" AR400 FLOOR
- 1- 34" 10 GA. FRONT
- 1- 24" 10 GA. SIDES
- 1- 34" 10 GA. SIX PANEL TAILGATE
- 1- AIR TAILGATE RELEASE
- 1- OAK SIDE BOARDS--SEALED
- 1- GREASEABLE LINKAGE AND HINGE POINTS
- 1- BONNELL FOLDING LADDER DRIVER SIDE OF BODY
- 1- 5/8" TARP RODS
- 1- STEEL FRONT FLAPS
- 1- REAR FLAPS
- 1- UNDERBODY PAINTED BLACK
- 1- UPPERBODY PAINTED TO MATCH CAB
- 1- STAINLESS STEEL COMBINATION TAILGATE PROP / SALT SHIELDS

CENTRAL HYDRAULIC SYSTEM:

- 1- HOT SHIFT PTO
- 1- TXV92 "LOAD SENSE" HYDRAULIC PUMP
- 1- ADD-A-STACK HYD.VALVE TO OPERATE HOIST,PLOW, AUGER / SPINNER
- 1- SC3100 ELECTRIC SPREADER CONTROLLER
- 1- BONNELL 30 GAL. STAINLESS STEEL HYDRAULIC TANK
- 1- BONNELL STAINLESS STEEL HYDRAULIC VALVE ENCLOSURE
- 1- HP3000 SERIES HIGH PRESSURE FILTER
- 1- LOW OIL / HIGH TEMPERATURE AUTO SHUT OFF SYSTEM
- 1- ALL REQUIRED PLUMBING

CONSOLE SYSTEM:

- 1- BONNELL CUSTOM CONSOLE
- 1- "MORSE" CABLE CONTROLS





1385 Franklin Grove Rd
Dixon, IL 61021
815-284-3819 \* 815-284-8815 Fax
800-851-9664
www.bonnell.com \* info@bonnell.com

Quote

Quote Number: 0133294
Quote Date: 4/15/2019



Bill To: 0002184
VILLAGE OF HAMPSHIRE
P O BOX 457
HAMPSHIRE, IL 60140-0457

Ship To: 01
VILLAGE OF HAMPSHIRE
234 S STATE ST
HAMPSHIRE, IL 60140

Phone: (847) 683-2181 Fax: (847) 683-4915 dstarrett@hampshireil.org

Phone:
Fax:

Confirm To: DAVID STARRETT Comment:

Table with 5 columns: Customer P.O., Ship VIA, F.O.B., Terms, Quote Expiration. Values include Net 30 Days and 5/15/2019.

Main item table with columns: Ordered, Unit, Item Number, Each Price, Extended Price. Lists various equipment items like HOIST, ELECTRICAL SYSTEM, LIGHT BAR SYSTEM, LIGHTING SYSTEM, and REAR HITCH.



1385 Franklin Grove Rd  
 Dixon, IL 61021  
 815-284-3819 \* 815-284-8815 Fax  
 800-851-9664  
 www.bonnell.com \* info@bonnell.com

# Quote

Quote Number: 0133294  
 Quote Date: 4/15/2019



**Bill To:** 0002184  
 VILLAGE OF HAMPSHIRE  
 P O BOX 457  
 HAMPSHIRE, IL 60140-0457

**Ship To:** 01  
 VILLAGE OF HAMPSHIRE  
 234 S STATE ST  
 HAMPSHIRE, IL 60140

Phone: (847) 683-2181 Fax: (847) 683-4915 dstarrett@hampshireil.org

Phone:  
 Fax:

**Confirm To:** DAVID STARRETT Comment:

Customer P.O.	Ship VIA	F.O.B.	Terms	Quote Expiration
			Net 30 Days	5/15/2019

Ordered	Unit	Item Number	Each Price	Extended Price
		CAB SHIELD - CUSTOM FABRICATED FOR SPECIFIED TRUCK AND BODY. CONFIGURED AS FOLLOWS:  *MATERIAL IS TO BE 201 STAINLESS STEEL. *PAN WIDTH- 18". *WIDTH- DETERMINED. *HEIGHT TO BE DETERMINED TO BOTTOM OF PAN. *4 REAR FACING OBLONG LIGHT HOLES. *UNPAINTED. *STAINLESS STEEL TO BE ELECTROCHEMICALLY CLEANED AND PASSIVATED.		
2.00	EACH	<b>PLOW HITCH</b> HITCH FOR SNOW PLOW PLOW HITCH FOR A WORKSTAR SFA 2011 EPA10 HITCH SHIPPED OUT TO CUSTOMER TYPE OF MOUNT - HEAVY FRONT FRAME -SIDE PLATES TYPE OF HITCH FRAME - QX HITCH (SIDE-BY-SIDE) BASE MODEL: HFF-QX		
2.00	EACH	<b>*H10400</b>  1/2" Side Plates. (Included in Standard Price of Side Plate Hitch)		
2.00	EACH	<b>*H10170</b>  4" X 10" Double Acting Cylinder W/Nitrided Rod		
2.00	EACH	<b>*H10300</b>  IDOT Grill mounted Light Brackets		
2.00	EACH	<b>*H10420</b>  Cross Over Relief Valve Kit (Installed or Not Installed)		
2.00	EACH	<b>PLOW</b>  12ST42MX1Q PRICE COMPLETE WITH OPTIONS		



1385 Franklin Grove Rd  
 Dixon, IL 61021  
 815-284-3819 \* 815-284-8815 Fax  
 800-851-9664  
 www.bonnell.com \* info@bonnell.com

# Quote

Quote Number: 0133294  
 Quote Date: 4/15/2019



**Bill To:** 0002184  
 VILLAGE OF HAMPSHIRE  
 P O BOX 457  
 HAMPSHIRE, IL 60140-0457

**Ship To:** 01  
 VILLAGE OF HAMPSHIRE  
 234 S STATE ST  
 HAMPSHIRE, IL 60140

Phone: (847) 683-2181 Fax: (847) 683-4915 dstarrett@hampshireil.org

Phone:  
 Fax:

**Confirm To:** DAVID STARRETT Comment:

Customer P.O.	Ship VIA	F.O.B.	Terms	Quote Expiration
			Net 30 Days	5/15/2019

Ordered	Unit	Item Number	Each Price	Extended Price
2.00	EACH	12' LONG STRAIGHT STEEL SNOW PLOW HEIGHT IS 42" FULL EXTENSION SPRING (MX)TUBULAR REVERSING ASSEMBLY PAINTED ORANGE POLYURETHANE ENAMEL <b>*NO RG</b> NO RUNNING GEAR REQUIRED		
2.00	EACH	<b>*P10130</b>		
2.00	EACH	Level Raise Lift System with Lift Chains for High Country Plows (MX1 & MC1) <b>*P10210</b>		
2.00	EACH	Quick attach loop (plow section installed) <b>*P10425</b>		
2.00	EACH	3/8" x 12" Rubber flap kit installed <b>*P10465</b>		
2.00	EACH	Plow stand - installed ( to hold hook up point @ desired height when detached ) <b>*P10470</b>		
2.00	EACH	36" Blaze orange markers <b>*P10500</b>		
2.00	EACH	Standard 5/8" x 6" C1084 Steel Cutting Edge <b>*P10530</b>		
2.00	EACH	3/4" x 6" Universal curb shoes (1 pair installed) <b>*P10555</b>		
		1/2" Quick Couplers installed (one set/per plow) pioneer PHD-4000-4		



1385 Franklin Grove Rd  
Dixon, IL 61021  
815-284-3819 \* 815-284-8815 Fax  
800-851-9664  
www.bonnell.com \* info@bonnell.com

# Quote

Quote Number: 0133294  
Quote Date: 4/15/2019



**Bill To:** 0002184  
VILLAGE OF HAMPSHIRE  
P O BOX 457  
HAMPSHIRE, IL 60140-0457

**Ship To:** 01  
VILLAGE OF HAMPSHIRE  
234 S STATE ST  
HAMPSHIRE, IL 60140

Phone: (847) 683-2181 Fax: (847) 683-4915 dstarrett@hampshireil.org

Phone:  
Fax:

**Confirm To:** DAVID STARRETT Comment:

Customer P.O.	Ship VIA	F.O.B.	Terms	Quote Expiration
			Net 30 Days	5/15/2019

Ordered	Unit	Item Number	Each Price	Extended Price
---------	------	-------------	------------	----------------

2.00 EACH **UT SPREADER**

- MODEL U696-DD-S2-24L-1 UNDER TAILGATE SPREADER
- \* 6" AUGER DIAMETER, 4" PITCH
- \* DIRECT DRIVE WITH A 22.8 CUBIC INCH MOTOR
- \* FABRICATED OF 201 STAINLESS STEEL MATERIAL
- \* SPREADER SHALL HAVE ONE DROP PORT
- \* DROP PORT(S) IS 24" OFFSET FROM LEFT SIDE
- \* AUGER SHALL HAVE REVERSE FLIGHTING
- \* ONE SPINNER ASSEMBLY
- \* SPINNER(S) ARE POWERED BY 2.8 CUBIC INCH MOTOR(S)
- \* 18" POLYURETHANE SPINNER DISC
- \* INCLUDES MOUNTING HARDWARE
- \* DEDUCT TAILGATE SHIELDS

2.00 EACH **PREWET SYSTEM**

- BONNELL CONFIGURED PREWET SYSTEM
- TYPE: TAILGATE SYSTEM
- OPEN LOOP SYSTEM
- ELECTRIC LIQUID PUMP
- SEE BELOW FOR DETAILS

2.00 EACH **\*TG-100P-1-150**

Tailgate Mounted Prewet System with one 100 Gallon Poly Tanks, Stainless Steel Tank Brackets, and 1-1/2" Plumbing.

2.00 EACH **\*L10160**

Electric Prewet Pump in a Tank Mounted Enclosure to Operate a Open Loop System.

2.00 EACH **\*L10315**

2" Male Quick Fill Kit Installed.

2.00 EACH **\*L10330**



1385 Franklin Grove Rd  
 Dixon, IL 61021  
 815-284-3819 \* 815-284-8815 Fax  
 800-851-9664  
 www.bonnell.com \* info@bonnell.com

# Quote

**Quote Number:** 0133294  
**Quote Date:** 4/15/2019



**Bill To:** 0002184  
 VILLAGE OF HAMPSHIRE  
 P O BOX 457  
 HAMPSHIRE, IL 60140-0457

**Ship To:** 01  
 VILLAGE OF HAMPSHIRE  
 234 S STATE ST  
 HAMPSHIRE, IL 60140

Phone: (847) 683-2181 Fax: (847) 683-4915 dstarrett@hampshireil.org

Phone:  
 Fax:

**Confirm To:** DAVID STARRETT Comment:

Customer P.O.	Ship VIA	F.O.B.	Terms	Quote Expiration
			Net 30 Days	5/15/2019

Ordered	Unit	Item Number	Each Price	Extended Price
		Two Nozzle spray kit Installed.		
2.00	EACH	*L10360		
		Pressure Switch (For Shutting Down Electric Pumps) Installed.		

**15% RESTOCKING FEE ON RETURNED ITEMS**  
**NO RETURN ON SPECIAL ORDER ITEMS OR ELECTRICAL ITEMS**

SUBMITTED BY: \_\_\_\_\_  
 0009 Dan Cruz TG

Net Order:	143,900.00
Less Discount:	0.00
Freight:	0.00
Sales Tax:	0.00
<b>Quote Total:</b>	<b>143,900.00</b>

NOTE: ALL TAXES WILL BE EXTRA IF APPLICABLE.  
 NOTE: PRICES ARE IN EFFECT FOR 30 DAYS ONLY. IF A PRICE INCREASE OCCURS - IT WILL BE ADDED.

NOTE: BIDS MAY REQUIRE A 20% DEPOSIT UPON PURCHASE  
 NOTE: INSTALL DATE IS BASED ON CHASSIS ARRIVAL DATE.

ACCEPTED BY: \_\_\_\_\_  
 \*\*BILL TO: \_\_\_\_\_  
 PO Number: \_\_\_\_\_  
 DATE ACCEPTED: \_\_\_\_\_  
 CHASSIS ARRIVAL DATE: \_\_\_\_\_

VIN# \_\_\_\_\_  
 MAKE: \_\_\_\_\_  
 MODEL: \_\_\_\_\_  
 W.B. \_\_\_\_\_ C.A.: \_\_\_\_\_  
 TRANS MODEL: \_\_\_\_\_  
 ENGINE: \_\_\_\_\_  
 PAINT CODE: \_\_\_\_\_

**\*\*CHANGES MAY CAUSE DELAYS AND FEES.**



**Monroe Truck Equipment**  
 1051 W 7th Street  
 Monroe, WI 53566  
 Ph./Fax: 608-329-8383/608-329-8521  
 www.MonroeTruck.com



Awarded Contract  
 #080114-MTE



**QUOTATION**  
**# 9TRR001980**

Job Order #: \_\_\_\_\_  
 Quote Date: 4/17/2019  
 Quote valid until: 5/17/2019  
 Terms: NET 30  
 Salesperson: SZYMCZAK, STEVE (MUNI)  
 Quoted by: Tim Reynolds  
 Email: treynolds@monroetruck.com

**Customer:** HAMPSHIRE,VILL OF  
 234 S STATE ST  
 PO BOX 457  
 HAMPSHIRE, IL 60140

**Contact:** \_\_\_\_\_

**Phone:** 847-683-2181 **Fax:** 847-683-4915

**Email:** \_\_\_\_\_

**Dealer Code:** \_\_\_\_\_

**Sourcwell Member #:** \_\_\_\_\_

**P.O. Number:** \_\_\_\_\_

**Re-Assign (Required for all pool units):**  Fleet  Retail  
**MSO/MCO (ONLY check if legally required):**  MSO  MCO

**Accepted by:** \_\_\_\_\_ **Date:** \_\_\_\_\_  
*Customer must fill out all information above before the order can be processed.*

**Chassis Information**

Year:	Make:	Model:	Chassis Color:	Cab Type:
Single/Dual: DRW	CA:	CT:	Wheelbase:	Engine: DIESEL
			F.O. Number #:	Vin:

**Comments:**

**Monroe Truck Equipment, Inc. is pleased to offer the following quote for your review:**

Description	Amount
DUMP BODY - 10', 5-7 YARD CAPACITY, CRYSTEEL GLADIATOR	
- SIDES: 26", 7GA	
- FRONT: 36", 7GA	
- REAR: 36", 7GA	
- FLOOR: 1/4" AR400 9" RADIUS	
- WESTERN UNDERSTRUCTURE	
- 3/8" X 1 1/2" FLAT WALK RAIL BOTH SIDES	
- CAB SHIELD	
- 2" X 10" OAK SIDE BOARDS (NOT PAINTED)	
- SLIDE-OUT LADDER & GRAB HANDLE ON RIGHT SIDE OF BODY	
- REFLECTIVE TAPE ACROSS THE BACK OF THE CAB AND SIDES OF BODY	
- SELF ADJUSTABLE 87-107 DB BACKUP ALARM	
- RECESSED LED S/T/T AND BACKUP LIGHTS WITH SEALED WIRE HARNESS	
- RUBBER REAR FLAPS	
- SS SPLASH GUARDS IN FRONT OF REAR TIRES	
- PAINTED ONE COLOR	
CRYSTEEL RC750 SUBFRAME HOIST	
- 17.2 TON CAPACITY	
- 2000 P.S.I.	
- FULLY GREASABLE HINGE AND ROLLERS	
- DOUBLE ACTING	
LIGHTS - WHELEN, JUSTICE SUPER LED ILL STROBE SYSTEMS, 72" LIGHT BAR	
- 72" JUSTICE LED LIGHT BAR MOUNTED ON ROOF	
- LED S/T/T MOUNTED IN REAR POST, PINTLE PLATE AND ON TOP OF CAB SHIELD	
- LED BACK UP LIGHT MOUNTED IN REAR CORNER POST	
- 2 AMBER AND 1 CLEAR STROBE INSTALLED OUTSIDE THE CORNER POST ON EACH SIDE	
- 2-YEAR WARRANTY	
PINTLE HOOK - W/MOUNTING, 50 TON SINGLE AXLE	
MANUAL/ELECTRIC HYDRAULICS PACKAGE	
- HOT SHIFT PTO	
- TXV92 PUMP	
- HOIST: 4 WAY/3POS, W/500 PSI A PORT RELIEF, 40 GPM	
- MANUAL LOAD SENSE MID-INLET SECTION, 2500 PSI MAIN RELIEF	
- PLOW LIFT: 4 WAY/3POS, 20 GPM, MANUAL	
- PLOW ANGLE: 4 WAY/3POS, 20 GPM, MANUAL	
- AUGER: 2 WAY, 14 GPM	

**Description**

**Amount**

- SPINNER: 2 WAY, 7 GPM
- 30 GALLON CAPACITY STAINLESS HYDRAULIC RESERVOIR WITH INTERNAL FILTER
- FILLER/BREATHER CAP, LEVEL/TEMP SIGHT GLASS, 3/4" MAGNETIC PLUG,
- 60 P.S.I. CONDITION INDICATOR
- STAINLESS ENCLOSURE WITH WEATHER TIGHT COVER
- HYDRAULIC ENCLOSURE WILL BE MOUNTED ON FRAME RAIL
- MANUAL LEVER CONTROLS
- FORCE 3100-3F SPREADER CONTROL WITH PRE-WET
- INSTALLED

- MONROE LDS-333 ELECTRIC TRUCK MOUNTED LIQUID DISPENSING SYSTEM
- ELECTRIC 12 VDC SEALED 3 GPM PUMP/MOTOR COMBINATION W/ INTEGRAL PUMP SHUT-OFF SWITCH ALL WITHIN SEALED NEMA FIBERGLASS ENCLOSURE
  - TWO (2) 1 GPM BRASS SPRAY NOZZLES, STRAINER AND HOSES FOR APPLYING LIQUID
  - 100 GALLON TAILGATE MOUNTED TANK WITH SS BRACKETS
  - BULK FILL
  - TAILGATE PROPS

- TRUCK PORTION - FLAT-FOLD LIFT ARM HITCH W/ INTEGRAL QCP RECEIVER
- 1/2" CHEEK PLATES
  - 4" X 10" D LIFT CYLINDER
  - SS PLOW LIGHT BRACKETS HOOD MOUNTED
  - ABL HALOGEN PLOW LIGHTS
  - MODIFY O.E. BUMPER
  - (REQUIRES MINIMUM OF 18" FRONT FRAME EXTENSION)

- MONROE FULL MOLDBOARD TRIP REVERSIBLE PLOW
- 41" TALL X 12' WIDE
  - 10 GAUGE ROLL FORMED STRAIGHT MOLDBOARD
  - (6) 1/2" X 4" TAPERED, ONE-PIECE FLAME CUT RIBS
  - 2" X 3" X 3/8" TOP MOLDBOARD ANGLE
  - 4" X 4" X 3/4" BOTTOM MOLDBOARD ANGLE
  - HORIZONTAL MOLDBOARD BRACE ANGLES
  - 5/8" X 8" ONE-PIECE TOP PUNCH CUTTING EDGE
  - DUAL COMPRESSION TRIP SPRING ASSEMBLIES
  - HD TUBULAR PUSH FRAME
  - (2) 3" X 15" DOUBLE ACTING POWER REVERSE CYLINDERS WITH CUSHION VALVE
  - BUILT-IN MONROE LEVEL LIFT ASSEMBLY
  - MOLDBOARD AND PUSHFRAME 100% CONTINUOUSLY WELDED
  - MOLDBOARD POWDER COATED ORANGE
  - PUSH FRAME POWDER COATED BLACK
  - LOOP HITCH

**INCLUDES**

- RUBBER SNOW DEFLECTOR
- (2) CURB SHOES
- SCREW ADJUSTABLE PARKING JACK
- 36" FLOURESCENT MARKERS

- MONROE UNDER-TAILGATE, DIRECT DRIVE SPREADER (MS966-RF-DD)
- 201 STAINLESS STEEL
  - 6" DIA. AUGER W/ REVERSE FLIGHTING FOR LEFT OF CENTER DISCHARGE
  - 7 GA., 96" TROUGH W/ 1/4" END PLATES
  - ONE-PIECE, REMOVABLE & HINGED, COMBINATION COVER & REAR PANEL
  - HEAVY-DUTY, STEEL ROD, CAPTIVE LATCHES
  - QUICK DETACH MOUNTING BRACKETS
  - SS SPINNER ASSY WITH POLY DISC
  - TAILGATE SHIELDS
  - INSTALLED

Quote Total: \$57,821.00

**Additional Options:**

**Description**

STAINLESS STEEL BODY UPCHARGE  
\* ADD TO ABOVE PRICE

**Amount**  
\$4,612.00

**Add to quote?**  
Yes / No

*\$1,200 Paint*

**Notes:**

- ◆ Terms are Due Upon Receipt unless prior credit arrangements are made at the time of order.
- ◆ Please note if chassis is furnished, it is as a convenience and terms are Net Due on Receipt of Chassis.
- ◆ State and Federal taxes will be added where applicable. **Out-of-state municipal entities may be subject to Wisconsin sales tax.**
- ◆ Restocking fees may be applicable for cancelled orders.
- ◆ MTE is not responsible or liable for equipment that does not meet local/state regulations if those laws are not made known at time of order.

---

## AGENDA SUPPLEMENT

---

**TO: President Magnussen and Village Board**

**FROM: Lori Lyons, Finance Director**

**FOR: May 2, 2019 Village Board Meeting**

**RE: 2019 Road Improvements**

---

**Background.** The FY20 Road and Bridge Fund budget included expenditures of \$150,000 to improve the Village streets and roads. This will fully expend the road and bridge funds expected to be received this real estate tax funding cycle (\$109,043) plus surplus from prior years. We will discuss the merits of a full tear out versus milling and overlay at the meeting. Due to concerns about the underlayment of Jake Lane Street Supervisor David Starrett asked that Schroeder provide alternate quotes for tear out. For comparative purposes below, it is estimated that the pavement is 5” thick on Jake Lane.

**Analysis.** The quotes received are summarized below; prices are for mill and overlay unless designated otherwise:

<b>Vendor</b>	<b>Champion</b>	<b>Schroeder</b>
Higgins (Route 20 to butt joint)	23,850	18,308 (s)
Alley behind Village Hall	13,600 (t)	16,875
Panama (Centennial to Smith)	19,200 (t)	9,646
Jake Lane (Centennial to Warner)	72,900 (t)	42,872
<b>Quote Total</b>	<b>\$129,550</b>	<b>\$87,701</b>
Remove Jake		(42,872)
Jake tear out and replacement (5”est)		86,296
<b>Quote Total with Jake Alternate</b>	<b>\$129,550</b>	<b>\$131,125</b>
Striping	29,942	29,941
Crack Sealing (Kane Co Bid Price)	19,765	19,765
<b>Adjusted Total</b>	<b>\$179,257</b>	<b>\$180,831</b>
Remove Panama	(19,200)	(9,646)
Striping included in Street Budget	(10,000)	(10,000)
<b>Expenditure Request</b>	<b>\$150,057</b>	<b>\$161,185</b>

s = includes striping  
t = bid if for tear out



Due to the cost of the projects requested this year and as reflected above, it is proposed that the east bound lane of Panama be patched in lieu of tear out or mill and overlay this year.

Staff is comfortable with the work of both contractors providing quotes for the above projects.

**Recommendation.** Staff requests the board waive the formal bidding requirements for the projects listed above and authorize staff to accept the quote from Champion Paving, Corp. in the amount of \$110,350.00 (removing Panama) to be paid for out of the Road and Bridge Fund (Higgins stripping will be done in house), and also authorize acceptance of the AC Pavement Striping Company quotes totaling of \$49,706.56; \$29,941.36 for striping and \$19,765.20 for crack sealing.

Total Road and Bridge Expenditures: \$150,056.56

Street Division Expenditures: \$10,000.00



P.O. Box 610  
Hampshire, IL 60140-0610

Bob Waterworth  
President

ChampionPaving@aol.com

(847) 683-8383  
fax (847) 683-7533

David Starrett  
Village of Hampshire  
234 S State St  
POB 457  
Hampshire, IL 60140

**RE: Various Road Improvements**

**Submitted: Friday, April 26, 2019**

We propose to furnish all necessary labor, material, tools, equipment, and supervision to complete the following:

**Higgins Road:** Grind 2" off existing pavement. Clean, tack and install 2" new asphalt surface. Striping and marking on shoulder by others. Road measures approximately 1,243 S. Yds. **\$23,850.00**

**Panama:** Sawcut and remove old asphalt down to gravel base. Regrade existing gravel base and compact. Install 2 1/2" asphalt binder and 1 1/2" asphalt surface. Area per white marks measure approximately 768 S. Yds. **\$19,200.00** *~ 110,350*

**Jake Lane - 300 Block:** Remove old asphalt down to gravel base. Regrade existing gravel base and compact. Install 2 1/2" asphalt binder and 1 1/2" asphalt surface. Road measures approximately 3,140 S. Yds. **\$72,900.00**

**Alley behind Village Hall:** Remove old asphalt down to gravel base. Regrade and compact. Install 2 1/2" asphalt binder and 1 1/2" asphalt surface. Alley measures approximately 467 S. Yds. **\$13,600.00**

Property owner responsible for all permits.

*\$129,550*

All of the above work to be completed in a workmanlike manner.

Note: Due to rising asphalt costs and volatile material prices, the above **price is quoted until 6-1-2019**

Terms: 100% of labor material and equipment as work progressed, due upon completion of work specified in this contracts.

Any changes from the above written amount of work to be performed involving extra cost of material or labor subjects the above contract to an additional charge unless said changes are accepted in writing. This proposal null and void if not accepted within 90 days of date submitted. We carry Workmen's Compensation insurance and Public Liability insurance. Champion Paving Corp. shall be entitled to the recovery of all reasonable attorney's fees and costs incurred in connection with any dispute hereunder or in connection with any action involving the recovery of amounts due hereunder.

Respectfully submitted,

**CHAMPION PAVING CORPORATION**

By

*Bob Waterworth*  
Robert Waterworth, President

ACCEPTANCE

You are hereby authorized to furnish all material and labor required to complete the work mentioned in the above proposal, for which the undersigned agrees to pay amount mentioned in said proposal, and according to term thereof. It is hereby agreed that a facsimile copy of this quotation signed by both parties constitutes a legal and binding agreement.

Date \_\_\_\_\_, 2019 \_\_\_\_\_

Printed \_\_\_\_\_

# 137,407.64  
=

# SCHROEDER ASPHALT SERVICES, INC.

**HCSS**  
PO. BOX 831  
HUNTLEY, IL 60142

PHONE: (815) 923-4380  
FAX: (815) 923-4389

<u>Quote To:</u>	VILLAGE OF HAMPSHIRE	<u>Job Name:</u>	2019 STREET REHAB PROGRAM
<u>Phone:</u>		<u>Date of Plans:</u>	
<u>Fax:</u>		<u>Proposal #</u>	P19138
<u>Contact:</u>	DAVE S.	<u>Estimator:</u>	KYLE JOUSTRA
		<u>Date:</u>	3/13/19

ITEM	DESCRIPTION	QUANTITY	UNIT	UNIT PRICE	AMOUNT
	<b>HIGGINS RD (FROM RT20 TO BUTT JOINT)</b>				
10	1.5" MILL EXISTING HMA	1,300.00	SY	2.85	3,705.00
20	SWEEP & TACK COAT	1,300.00	SY	0.30	390.00
30	2" HMA N50 SURFACE	146.90	TON	89.95	13,213.66
35	24" WHITE STOP BAR	12.00	LF	3.30	39.60
40	4" YELLOW PAINTED LINE	960.00	LF	0.50	480.00
50	4" WHITE PAINTED LINE	960.00	LF	0.50	480.00
	<b>TOTAL FOR HIGGINS RD</b>				<b>\$18,308.26</b>
	<b>JAKE LN (CENTENNIAL TO WARNER)</b>				
60	1.75" MILL EXISTING HMA	3,220.00	SY	2.85	9,177.00
70	SWEEP & TACK COAT	3,220.00	SY	0.30	966.00
80	2" HMA N50 SURFACE	363.86	TON	89.95	32,729.21
	<b>TOTAL FOR JAKE LN</b>				<b>\$42,872.21</b>
	<b>PANAMA (CENTENNIAL TO SMITH)</b>				
90	1.75" MILL EXISTING HMA	725.00	SY	2.85	2,066.25
100	SWEEP & TACK COAT	725.00	SY	0.30	217.50
110	2" HMA N50 SURFACE	81.85	TON	89.95	7,362.41
	<b>TOTAL FOR PANAMA AVE</b>				<b>\$9,646.16</b>
	<b>ALLEY (JACKSON AND JEFFERSON)</b>				
120	3.5" MILL EXISTING HMA	495.00	SY	9.50	4,702.50
130	FINE GRADE & COMPACT EXISTING STONE	495.00	SY	1.65	816.75
140	2" HMA N50 BINDER	55.94	TON	110.00	6,153.40
150	1.5" HMA N50 SURFACE	41.95	TON	124.00	5,201.80
	<b>TOTAL FOR ALLEY</b>				<b>\$16,874.45</b>
	<b>UNIT PRICING FOR UNFORSEEN ITEMS</b>				
160	3" CLASS D BINDER PATCHES	1.00	SY	33.00	33.00



PO. BOX 831  
HUNTLEY, IL 60142

# SCHROEDER

## ASPHALT SERVICES, INC.

PHONE: (815) 923-4380  
FAX: (815) 923-4389

Quote To: VILLAGE OF HAMPSHIRE

Job Name: JAKE LANE

Phone:

Date of Plans:

Fax:

Proposal #

P19257

Contact:

DAVE S.

Estimator:

KYLE JOUSTRA

Date:

4/29/19

PLEASE SEE THE TWO OPTIONS SHOWN BELOW

ITEM	DESCRIPTION	QUANTITY	UNIT	UNIT PRICE	AMOUNT
<b>OPTION I - 5" REMOVAL &amp; REPLACEMENT</b>					
10	5" MILL	3,220.00	SY	3.55	11,431.00
20	FINE GRADE & COMPACT EXISTING STONE	3,220.00	SY	1.00	3,220.00
30	3.5" HMA N50 BINDER	636.76	TON	74.50	47,438.62
40	1.5" HMA N50 SURFACE	272.90	TON	88.70	24,206.23
<b>TOTAL FOR 5" R&amp;R</b>					<b>\$86,295.85</b>
<b>OPTION II - 6" REMOVAL &amp; REPLACEMENT</b>					
50	6" MILL	3,220.00	SY	4.40	14,168.00
60	FINE GRADE & COMPACT EXISTING STONE	3,220.00	SY	1.00	3,220.00
70	4.5" HMA N50 BINDER	818.69	TON	71.75	58,741.01
80	1.5" HMA N50 SURFACE	272.90	TON	88.70	24,206.23
<b>TOTAL FOR 6" R&amp;R</b>					<b>\$100,335.24</b>



**S.K.C. CONSTRUCTION INC.**

P.O. BOX 503

WEST DUNDEE, IL 60118

PHONE NO. (847) 214-9800

F A X (847) 214-9023

LOCATION: ATTN. David Starrett  
Street Supervisor  
Village of Hampshire  
234 S. State St. P.O. Box 457

Completion

Hampshire, IL 60140  
VARIOUS STREETS  
190405KB

COUNTY Kane

---> QUOTE NO >

BID DATE 04/05/19

ITEM NO.	DESCRIPTION OF ITEMS	UNIT	QUANTITY	UNIT PRICE	TOTAL
	CLEAN PREP AND CRACK SEAL CRACKS 3/8" OR WIDER WITH HOT APPLIED FIBER MODIFIED ASPHALT PER IDOT LR 45' SPEC	CF	7,059.00	\$2.800	\$19,765.20

**Street List Includes:**

- 1 Prairie St From: Rinn to: Terwilliger, 1,170LF  
Warner From: Washington To: RTE 72.
- 2 3,377LF  
Ketchum Rd From PVT change To Big
- 3 Timber Ro. 2,156LF

**\*\*\* ALL MATERIALS SHALL MEET  
STATE OF ILLINOIS SPECIFICATIONS.**

**THANK YOU FOR CONSIDERING OUR BID!  
WE LOOK FORWARD TO HELPING YOU DEVELOP A SUCCESSFUL PROJECT.**

BID TOTAL \$19,765.20

DATE \_\_\_\_\_ 20\_\_\_\_\_

ACCEPTED BY \_\_\_\_\_

RESPECTFULLY SUBMITTED,  
S.K.C. CONSTRUCTION, INC  
KEVIN A BERGQUIST  
PROJECT MANAGER

# VILLAGE OF HAMPSHIRE

Accounts Payable

**May 2, 2019**

The President and Board of Trustees of the Village of Hampshire  
Recommends the following Warrant in the amount of

**Total: \$331,140.35**

To be paid on or before  
May 8, 2019

Village President: \_\_\_\_\_

Attest: \_\_\_\_\_

Village Clerk: \_\_\_\_\_

Date: \_\_\_\_\_

# VILLAGE OF HAMPSHIRE

Accounts Payable

**May 2, 2019**

The President and Board of Trustees of the Village of Hampshire  
Recommends the following **Employee/Trustee: Brian Haydysch, Dan Paradies, and Nicholas Orsolini**  
Warrant in the amount of

**Total: \$240.00**

To be paid on or before  
May 8, 2019

Village President: \_\_\_\_\_

Attest: \_\_\_\_\_

Village Clerk: \_\_\_\_\_

Date: \_\_\_\_\_



DATE: 04/30/19  
 TIME: 15:17:00  
 ID: AP441000.WOW

VILLAGE OF HAMPSHIRE  
 DETAIL BOARD REPORT

INVOICES DUE ON/BEFORE 07/31/2019

INVOICE #	INVOICE DATE	INVOICE #	DESCRIPTION	ACCOUNT #	P.O. #	DUE DATE	ITEM AMT
B&F	B&F CONSTRUCTION CODE SERVICES						
11260	04/17/19	01	MAR'S PLAN REVIEWS/INSPECTIONS	010010024390		05/19/19	6,068.44
						INVOICE TOTAL:	6,068.44
51127	04/15/19	01	LOVE'S FIRE DETECTION PLAN REV	010010024390		05/17/19	200.00
						INVOICE TOTAL:	200.00
						VENDOR TOTAL:	6,268.44
BECO	BESTLER CORP						
108540	04/05/19	01	BACKFLOW TESTS	300010024160		05/07/19	719.55
						INVOICE TOTAL:	719.55
						VENDOR TOTAL:	719.55
BEFA	BEAN'S FARM LANDSCAPE SUPPLY						
12994	04/22/19	01	YARD RESTORE	010030024130		05/24/19	150.00
						INVOICE TOTAL:	150.00
						VENDOR TOTAL:	150.00
BPCI	BENEFIT PLANNING CONSULTANTS,						
BPCI00198441	04/10/19	01	MONTHLY FLEX AND COBRA	010010024380		05/21/19	115.00
						INVOICE TOTAL:	115.00
						VENDOR TOTAL:	115.00
BRHA	BRIAN HAYDYSCH						
MAY 2019	04/28/19	01	CELL PHN REIMBURSEMENT MAR/APR	010020024230		05/28/19	80.00
						INVOICE TOTAL:	80.00
						VENDOR TOTAL:	80.00
COCR	COON CREEK SOD FARMS						
6884	04/23/19	01	SOD YARD RESTORE	010030024130		05/25/19	5.30
						INVOICE TOTAL:	5.30
						VENDOR TOTAL:	5.30

DATE: 04/30/19  
 TIME: 15:17:00  
 ID: AP441000.WOW

VILLAGE OF HAMPSHIRE  
 DETAIL BOARD REPORT

INVOICES DUE ON/BEFORE 07/31/2019

INVOICE #	INVOICE DATE	ITEM #	DESCRIPTION	ACCOUNT #	P.O. #	DUE DATE	ITEM AMT
COMED	COMED						
MAY FOR JUNE 2019	04/11/19	01	5175128047	010030024260		06/11/19	1,228.65
		02	2244132001	010030024260			2,176.69
		03	0710116073	010030024260			61.92
		04	3461028010	010030024260			87.36
		05	1329062027	010030024260			11.26
		06	0524674020	010030024260			19.04
		07	4623084055	010030024260			41.48
		08	0657057031	010030024260			184.75
		09	1862215004	300010024260			2,036.04
		10	4997016005	310010024260			155.48
		11	9705026025	300010024260			693.62
		12	6987002019	300010024260			75.77
		13	0495111058	300010024260			74.30
		14	2599100000	300010024260			1,286.29
		15	2289551008	300010024260			106.44
		16	2676085011	300010024260			1,960.97
		17	0255144168	300010024260			649.73
		18	0030163001	300010024260			604.30
		19	1532148012	300010024260			296.40
		20	2323117051	300010024260			124.90
		21	0729114032	310010024260			40.75
		22	7101073024	310010024260			460.33
		23	1939142034	310010024260			366.71
		24	4755010063	300010024260			948.33
						INVOICE TOTAL:	13,691.51
						VENDOR TOTAL:	13,691.51

CONEEN CONSTELLATION NEW ENERGY

14637364701 04/17/19 01 ENERGY CHARGES 300010024260

INVOICE TOTAL: 107.39  
 VENDOR TOTAL: 107.39

COUNSCDI COMMUNITY UNIT SCHOOL DIST 300

INVOICE #	INVOICE DATE	ITEM #	DESCRIPTION	ACCOUNT #	P.O. #	DUE DATE	ITEM AMT
COUNSCDI COMMUNITY UNIT SCHOOL DIST 300							
MAY 2019	04/30/19	01	DISBURSEMENT OF TRANSITION FEE	600010044800		05/30/19	10,919.04
						INVOICE TOTAL:	10,919.04
						VENDOR TOTAL:	10,919.04
CREL CRESCENT ELECTRIC SUPPLY CO							
S506373487.001	04/11/19	01	LED STREET LIGHT LAMPS	010030024270		05/13/19	1,480.75
						INVOICE TOTAL:	1,480.75
						VENDOR TOTAL:	1,480.75
DAPA DAN PARADIES							
MAY 2019	04/29/19	01	CELL PHN REIMBURSEMENT MAR/APR	010020024230		05/29/19	80.00
						INVOICE TOTAL:	80.00
						VENDOR TOTAL:	80.00
DIEN DIRECT ENERGY BUSINESS							
MAY 2019	04/11/19	01	1510867	300010024260		05/13/19	981.13
		02	1510796	300010024260			2,274.69
		03	1510797	310010024260			5,645.81
		04	1510866	310010024260			232.13
						INVOICE TOTAL:	9,133.76
						VENDOR TOTAL:	9,133.76
ELLA ELLA JOHNSON LIBRARY							
MAY 2019	04/30/19	01	DISBURSEMENT OF TRANSITION FEE	610010044800		05/30/19	992.67
						INVOICE TOTAL:	992.67
						VENDOR TOTAL:	992.67
ENCS ENTRE COMPUTER SOLUTIONS							
00119990	01/14/19	01	SWITCH	310010024120		02/16/19	298.84
						INVOICE TOTAL:	298.84

INVOICES DUE ON/BEFORE 07/31/2019

INVOICE #	INVOICE DATE	INVOICE #	DESCRIPTION	ACCOUNT #	P. O. #	DUE DATE	ITEM AMT
122027	04/11/19	01	PW OFFICE COMPUTER	010030034650		05/13/19	749.31
						INVOICE TOTAL:	749.31
						VENDOR TOTAL:	1,048.15
GLSS	GREAT LAKES SNOW SYSTEMS						
5356	04/15/19	01	SNOW PLOW AND SALT	010030024200		05/17/19	2,022.50
						INVOICE TOTAL:	2,022.50
						VENDOR TOTAL:	2,022.50
HAAUPA	HAMPSHIRE AUTO PARTS						
518927	04/11/19	01	BRAKE CONTROLLER	310010034670		05/13/19	146.71
						INVOICE TOTAL:	146.71
519357	04/15/19	01	STREET LIGHTS TOOL	010030034670		05/17/19	10.80
						INVOICE TOTAL:	10.80
520142	04/23/19	01	AIR FILTER	010020024110		05/25/19	21.29
						INVOICE TOTAL:	21.29
520377	04/25/19	01	TIRE PATCH	520010024999		05/27/19	1.32
						INVOICE TOTAL:	1.32
						VENDOR TOTAL:	180.12
HAFD	HAMPSHIRE FIRE PROTECTION						
MAY 2019	04/30/19	01	PLYMOVENT	630010044800		05/30/19	2,230.44
						INVOICE TOTAL:	2,230.44
						VENDOR TOTAL:	2,230.44
HAIN	HAWKINS INC						
4482710	04/15/19	01	WWTP ALUM	310010034680		05/17/19	6,169.23
						INVOICE TOTAL:	6,169.23
						VENDOR TOTAL:	6,169.23

INVOICES DUE ON/BEFORE 07/31/2019

INVOICE #	INVOICE DATE	ITEM #	DESCRIPTION	ACCOUNT #	P.O. #	DUE DATE	ITEM AMT
HAPD HAMPSHIRE PARK DISTRICT							
MAY 2019	04/30/19	01	TRANSITION FEE DISTRIBUTION	620010044800		05/30/19	992.67
						INVOICE TOTAL:	992.67
						VENDOR TOTAL:	992.67
IEPAFISC IEPA							
MAY 2019	04/30/19	01	LOAN PAYMENT	310010044793		05/30/19	113,431.94
		02	LOAN PAYMENT	310010044794			16,118.00
						INVOICE TOTAL:	129,549.94
						VENDOR TOTAL:	129,549.94
IPODBA IPO/DBA CARDUNAL OFFICE SUPPLY							
612388-0	04/23/19	01	TONER	010010034650		05/25/19	161.84
						INVOICE TOTAL:	161.84
						VENDOR TOTAL:	161.84
IPRF ILLINOIS PUBLIC RISK FUND							
55147	04/15/19	01	JUNE'S WORKERS' COMP	010010024210		06/01/19	1,634.66
		02	JUNE'S WORKERS' COMP	300010024210			1,634.67
		03	JUNE'S WORKERS' COMP	310010024210			1,634.67
						INVOICE TOTAL:	4,904.00
						VENDOR TOTAL:	4,904.00
JAM JAMES CHRYSLER DODGE JEEP RAM							
31385	04/17/19	01	2500 MISFIRE	010030024110		05/19/19	453.86
						INVOICE TOTAL:	453.86
						VENDOR TOTAL:	453.86
JGUNIN J.G. UNIFORMS INC.							
54005	04/24/19	01	UNIFORM	010020034690		05/26/19	180.48
						INVOICE TOTAL:	180.48

INVOICE #	INVOICE DATE	ITEM #	DESCRIPTION	ACCOUNT #	P.O. #	DUE DATE	ITEM AMT
JGUNIN	J.G. UNIFORMS INC.						
54083	04/25/19	01	UNIFORM	010020034690		05/27/19	358.61
						INVOICE TOTAL:	358.61
						VENDOR TOTAL:	539.09
KONMIN	KONICA MINOLTA BUS SOLUTION						
258282436	04/22/19	01	MONTHLY MAINTENANCE	010020024340		05/24/19	135.23
						INVOICE TOTAL:	135.23
						VENDOR TOTAL:	135.23
LAAM	LAUTERBACH & AMEN, LLP						
35459	04/08/19	01	ACCOUNTING ASSISTANCE	010010024380		05/10/19	400.00
						INVOICE TOTAL:	400.00
						VENDOR TOTAL:	400.00
LEA	LEO'S TROPHIES						
1158	04/23/19	01	AWARD	010010034650		05/25/19	97.50
						INVOICE TOTAL:	97.50
						VENDOR TOTAL:	97.50
MEWE	METRO WEST COG						
3842	05/01/19	01	RENEWAL DUES	010010024430		06/01/19	3,500.00
						INVOICE TOTAL:	3,500.00
						VENDOR TOTAL:	3,500.00
MUWP	MUNICIPAL WELL & PUMP						
15586	04/22/19	01	WELL 7 SPARE EQUIPMENT	300010024120		05/24/19	68,960.00
						INVOICE TOTAL:	68,960.00
						VENDOR TOTAL:	68,960.00
NIOR	NICHOLAS ORSOLINI						

DATE: 04/30/19  
 TIME: 15:17:00  
 ID: AP441000.WOW

VILLAGE OF HAMPSHIRE  
 DETAIL BOARD REPORT

INVOICES DUE ON/BEFORE 07/31/2019

INVOICE #	INVOICE DATE	ITEM #	DESCRIPTION	ACCOUNT #	P.O. #	DUE DATE	ITEM AMT
NIOR NICHOLAS ORSOLINI							
MAY 2019	04/28/19	01	CELL PHN REIMBURSEMENT MAR/APR	010020024230		05/28/19	80.00
						INVOICE TOTAL:	80.00
						VENDOR TOTAL:	80.00
OEIP OEI PRODUCTS							
6405	04/04/19	01	GLOVES	300010034690		05/06/19	137.00
						INVOICE TOTAL:	137.00
6417	04/11/19	01	BP UNIFORM	010030034690		05/13/19	74.00
		02	GF UNIFORM	010030034690			123.50
		03	BC UNIFORM	010030034690			55.00
		04	LW UNIFORM	010030034690			169.00
		05	DS UNIFORM	010030034690			29.90
		06	SCREEN PRINT	010030024130			114.00
						INVOICE TOTAL:	565.40
						VENDOR TOTAL:	702.40
PECA PETTY CASH							
MAY 2019	04/30/19	01	HANIWIPES BT	010020024100		05/30/19	2.13
		02	PAPER PRODUCTS LV	010010034650			13.87
		03	CAKE FOR TRUSTEE LV	010010034650			29.95
						INVOICE TOTAL:	45.95
						VENDOR TOTAL:	45.95
PIBO RESERVE ACCOUNT							
MAY 2019	04/29/19	01	POSTAGE REFILL	010010034650		05/29/19	250.00
						INVOICE TOTAL:	250.00
						VENDOR TOTAL:	250.00
RAOH RAY O'HERRON CO., INC.							
1922146-IN	04/19/19	01	UNIFORM	010020034690		05/21/19	242.49
						INVOICE TOTAL:	242.49

INVOICES DUE ON/BEFORE 07/31/2019

INVOICE #	INVOICE DATE	ITEM #	DESCRIPTION	ACCOUNT #	P.O. #	DUE DATE	ITEM AMT
RAOH	RAY O'HERRON CO., INC.						
1922147-IN	04/19/19	01	UNIFORM	010020034690		05/21/19	213.10
						INVOICE TOTAL:	213.10
						VENDOR TOTAL:	455.59
RKQUSE	RK QUALITY SERVICES						
12427	04/16/19	01	OIL CHANGE	010020024110		05/18/19	38.66
						INVOICE TOTAL:	38.66
12430	04/16/19	01	REPAIR BRAKES	010020024110		05/18/19	489.70
						INVOICE TOTAL:	489.70
12449	04/22/19	01	ALTERNATOR/BRAKES	010020024110		05/24/19	963.55
						INVOICE TOTAL:	963.55
12514	04/29/19	01	REPAIR TIRE	010020024110		05/29/19	29.21
						INVOICE TOTAL:	29.21
						VENDOR TOTAL:	1,521.12
SCHM	FREDI BETH SCHMUTTE						
APRIL 2019A	04/03/19	01	CDBG/RLF CLOSEOUT PROJECT DEV	010010024380		04/03/19	876.21
						INVOICE TOTAL:	876.21
						VENDOR TOTAL:	876.21
SIARA	SIGN A RAMA						
8928	04/16/19	01	2003 DOWNTOWN CHARTS	010010024382		05/18/19	100.00
						INVOICE TOTAL:	100.00
						VENDOR TOTAL:	100.00
STAINS	STANDARD INSURANCE COMPANY						
MAY FOR JUNE 2019	04/16/19	01	ADM	010010014035		05/01/19	28.29



INVOICES DUE ON/BEFORE 07/31/2019

INVOICE #	INVOICE DATE	ITEM #	DESCRIPTION	ACCOUNT #	P.O. #	DUE DATE	ITEM AMT
STAINS STANDARD INSURANCE COMPANY							
MAY FOR JUNE 2019	04/16/19	02	PD	010020014035		05/01/19	179.13
		03	STREETS	010030014035			53.28
		04	SEWER	310010014035			14.14
		05	WATER	300010014035			33.01
						INVOICE TOTAL:	307.85
						VENDOR TOTAL:	307.85
TEK TEKLAB, INC							
227584	04/17/19	01	NPDES TESTING	310010024380		05/17/19	691.00
						INVOICE TOTAL:	691.00
						VENDOR TOTAL:	691.00
THBANEYO THE BANK OF NEW YORK							
252-2192076	04/19/19	01	2016 GO BOND ADM FEE	010010024380		06/15/19	90.00
		02	2016 GO BOND ADM FEE	050010024380			660.00
						INVOICE TOTAL:	750.00
MAY 2019							
	04/30/19	01	GO REF (ARS) 12	300010044703		05/30/19	7,101.35
		02	GO REF (ARS) 12	010030044790			2,249.18
		03	GO REF (ARS) 12	310010044794			2,893.22
						INVOICE TOTAL:	12,243.75
MAY 2019A							
	04/30/19	01	GO ARS 16	010010044690		05/30/19	2,625.00
		02	GO ARS 16	050010044690			19,250.00
						INVOICE TOTAL:	21,875.00
						VENDOR TOTAL:	34,868.75
TRUN TREES UNLIMITED							
12664	04/18/19	01	MULCH	010030024130		05/20/19	100.00
						INVOICE TOTAL:	100.00
7900							
	04/16/19	01	SNOW FLOW	010030024190		05/18/19	2,700.00
						INVOICE TOTAL:	2,700.00
						VENDOR TOTAL:	2,800.00

INVOICES DUE ON/BEFORE 07/31/2019

INVOICE #	INVOICE DATE	ITEM #	DESCRIPTION	ACCOUNT #	P.O. #	DUE DATE	ITEM AMT
VAIN	VAFCON INCORPORATED						
I181661	04/20/19	01	SCADA INSTALLATION	300010024160		05/22/19	6,200.00
						INVOICE TOTAL:	6,200.00
I181668	04/24/19	01	SCADA COOMMUNICATION UPGRADE	300010024120		05/26/19	6,200.00
						INVOICE TOTAL:	6,200.00
I191707	04/08/19	01	DIGESTER 7/8 TRANSDUCER REPAIR	310010024120		05/10/19	4,732.69
						INVOICE TOTAL:	4,732.69
I191717	02/26/19	01	WTP WELL 9	300010024120		03/28/19	125.00
						INVOICE TOTAL:	125.00
I191719	02/26/19	01	WWTP RAS CLARIFIER	310010024120		03/28/19	312.50
						INVOICE TOTAL:	312.50
I191720	04/20/19	01	MOBILE SCADA ACCESS	310010024120		05/22/19	250.00
						INVOICE TOTAL:	250.00
I191721	04/20/19	01	SCADA PRV LOGIC ADJUSTMENT	300010024160		05/22/19	125.00
						INVOICE TOTAL:	125.00
I191722	03/29/19	01	DIGESTER PH & ORP RETROFIT	310010024120		04/30/19	1,298.00
						INVOICE TOTAL:	1,298.00
						VENDOR TOTAL:	19,243.19
VERI	VERIZON WIRELESS						
9828267494	05/07/19	01	ADM	010010024230		06/07/19	55.97
		02	PD	010020024230			220.57
		03	STREETS	010030024230			279.85
		04	WATER	300010024230			101.97
		05	SEWER	310010024230			101.95
						INVOICE TOTAL:	760.31
						VENDOR TOTAL:	760.31

INVOICES DUE ON/BEFORE 07/31/2019

INVOICE #	INVOICE DATE	ITEM #	DESCRIPTION	ACCOUNT #	P.O. #	DUE DATE	ITEM AMT
VETO	VETO ENTERPRISES, INC						
30005	04/30/19	01	LIGHTSTICK REPAIR	010020054906		05/30/19	1,160.00
						INVOICE TOTAL:	1,160.00
						VENDOR TOTAL:	1,160.00
WSU	WATER SOLUTIONS UNLIMITED, INC						
30307	04/18/19	01	DWTP CHEMICALS	300010034680		05/20/19	2,430.00
						INVOICE TOTAL:	2,430.00
						VENDOR TOTAL:	2,430.00
						TOTAL ALL INVOICES:	331,380.35