



Village of Hampshire
Public Works Committee
November 18, 2023 - 9:00 AM-Noon
Hampshire Village Hall
234 South State Street, Hampshire, IL 60140

AGENDA, Committee of the Whole

1. Call to Order
2. Roll Call
3. Public Comments
4. A Motion to Approve the Meeting Minutes from February 20, 2020
5. Utilities Master Plan Presentation – Steve Dennison, EEI (No Action Requested)
 - a. Existing Water & Wastewater Systems Overview
 - b. Historical and Projected Water Use & Wastewater Flow
 - c. Water System Evaluation and Recommendations
 - d. Wastewater System Evaluation and Recommendations
6. New Business
7. Announcements
8. Adjournment

Public Comments: The Board will allow each person who is properly registered to speak a maximum time of five (5) minutes, provided the Village President may reduce the maximum time to three (3) minutes before public comments begin if more than five (5) persons have registered to speak. Public comment is meant to allow for expression of opinion on, or for inquiry regarding, public affairs but is not meant for debate with the Board or its members. Good order and proper decorum shall always be maintained.

Recording: Please note that all meetings held by videoconference may be recorded, and all recordings will be made public. While State Law does not require consent, by requesting an invitation, joining the meeting by link or streaming, all participants acknowledge and consent to their image and voice being recorded and made available for public viewing.

Accommodations: The Village of Hampshire, in compliance with the Americans with Disabilities Act, requests that persons with disabilities, who require certain accommodations to allow them to observe and/or participate in the meeting(s) or have questions about the accessibility of the meeting(s) or facilities, contact the Village at 847-683-2181 to allow the Village to make reasonable accommodations for these persons.



Village of Hampshire
Public Works Committee Meeting
February 20, 2020
Hampshire Village Hall – 234 S. State Street

MINUTES

1. The meeting was called to order at 5:30 pm by chairman Toby Koth.
2. Quorum was established - Mike Reid, Eric Robinson, and Toby Koth were present. Also present were Village Manager Jay Hedges, Assistant to the Village Manager Josh Wray, Streets Supervisor Dave Starrett, and Utilities Supervisor Mark Montgomery.
3. There were no Public Comments
4. Eric Robinson moved to approve the November 6, 2019, meeting minutes. Seconded by Mike Reid. Motion Carried.
5. Discussion of Condition of Public Works Trucks – Jay. Hedges discussed creating a Capital Improvement Program detailing Public Works Vehicles, their condition, and a replacement schedule. This will include replacement trucks in the proposed FY 2021 Village Budget and projections for the following two Fiscal Years.

Dave Starrett Commented that the lead times for Plow Trucks are 12 to 18 months out, and dealerships are not currently taking orders. He will be looking for vehicles in stock at local dealerships.

6. Discussion of Public Works Building – Mr. Hedges reported that he is working with EEI to determine the feasibility of adding on the current PW Garage, as the Committee has considered. This will be difficult because the proposed addition is in a flood plain.
7. Discussion of Equipment Needed for the Utilities Department. Mark Montgomery reported that he is working on repair and replacement priorities for the coming Fiscal Year and the following 2 years for the CIP. It will be a long list, but we will prioritize according to need and available funding.
8. No New Business
9. No Announcements
10. The Meeting was Adjourned at 6:45 PM

COMPREHENSIVE WATER AND WASTEWATER UTILITY MASTER PLANNING Workshop Primer



Water Supply



Water Treatment



Water Distribution
& Storage



Wastewater Collection
& Treatment



Stephen T. Dennison, PE
Vice President





Outline

1. Existing Water & Wastewater Systems Overview
2. Historical and Projected Water Use & Wastewater Flows
3. Water System Evaluation and Recommendations
4. Wastewater System Evaluation and Recommendations

A large stack of black pipes, likely for water or wastewater systems, is shown in an outdoor storage yard. The pipes are arranged in multiple rows, extending into the distance. The background is a clear sky. A dark green overlay covers the left side of the image, containing the title text.

OVERVIEW OF EXISTING WATER AND WASTEWATER SYSTEMS

EXISTING WATER WORKS SYSTEM

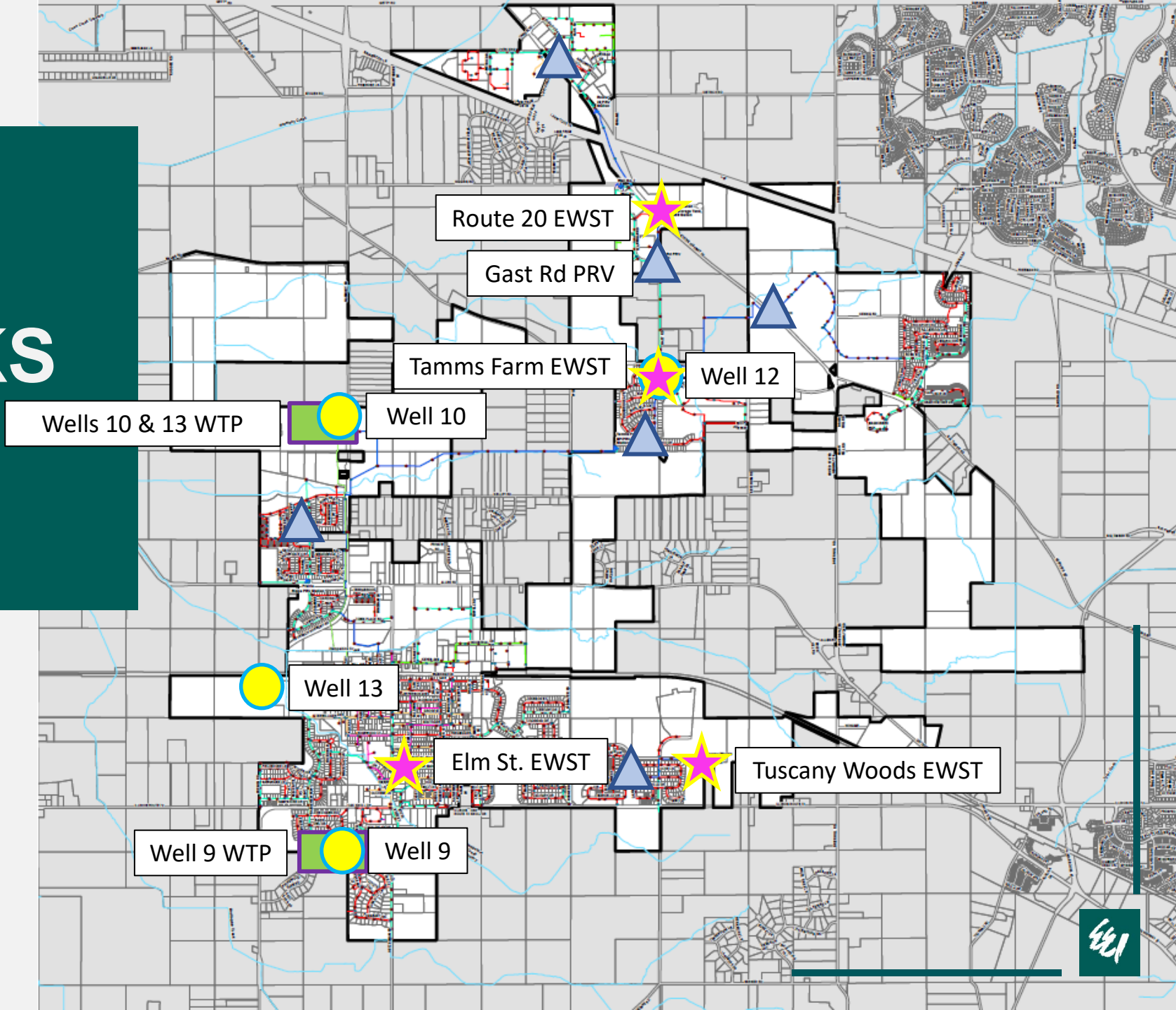
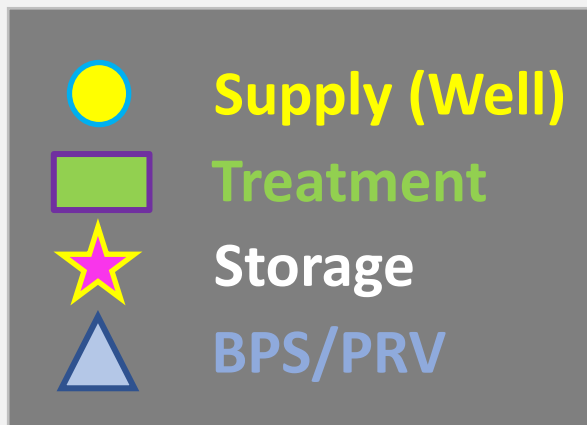

WATER SUPPLY

- Three (3) Active Deep Sandstone Water Wells (Nos. 9, 10, & 13)
 - Each Well Utilizes the Ironton-Galesville (Deep Sandstone) Formation
 - All Constructed Between 2004 and 2007
 - Flowrate: 1,000 – 1,200 gpm
 - Radium and Barium Concentrations Above Regulatory Standards – Requires Treatment
 - Deep Sandstone Aquifer Sustainability Analysis Not Included in Study
 - Well Performance Does Not Indicate Near-Term Concerns





WATER TREATMENT

- Two (2) Water Treatment Plants (WTPs)
 - Well 9 WTP – Operational in 2004
 - Wells 10 & 13 WTP – Operational in 2008
 - Both Plants Use Cation Exchange Treatment for Softening and Radium/Barium Removal
 - Wells 10 & 13 WTP Uses Aeration for Hydrogen Sulfide Removal (Aesthetic Concern from Well 10)
 - Chlorine Gas for Disinfection and Phosphate for Corrosion Control
 - No Permanent Emergency Backup Generators for Supply or Treatment



EXAMPLE WATER TREATMENT SCHEMATIC

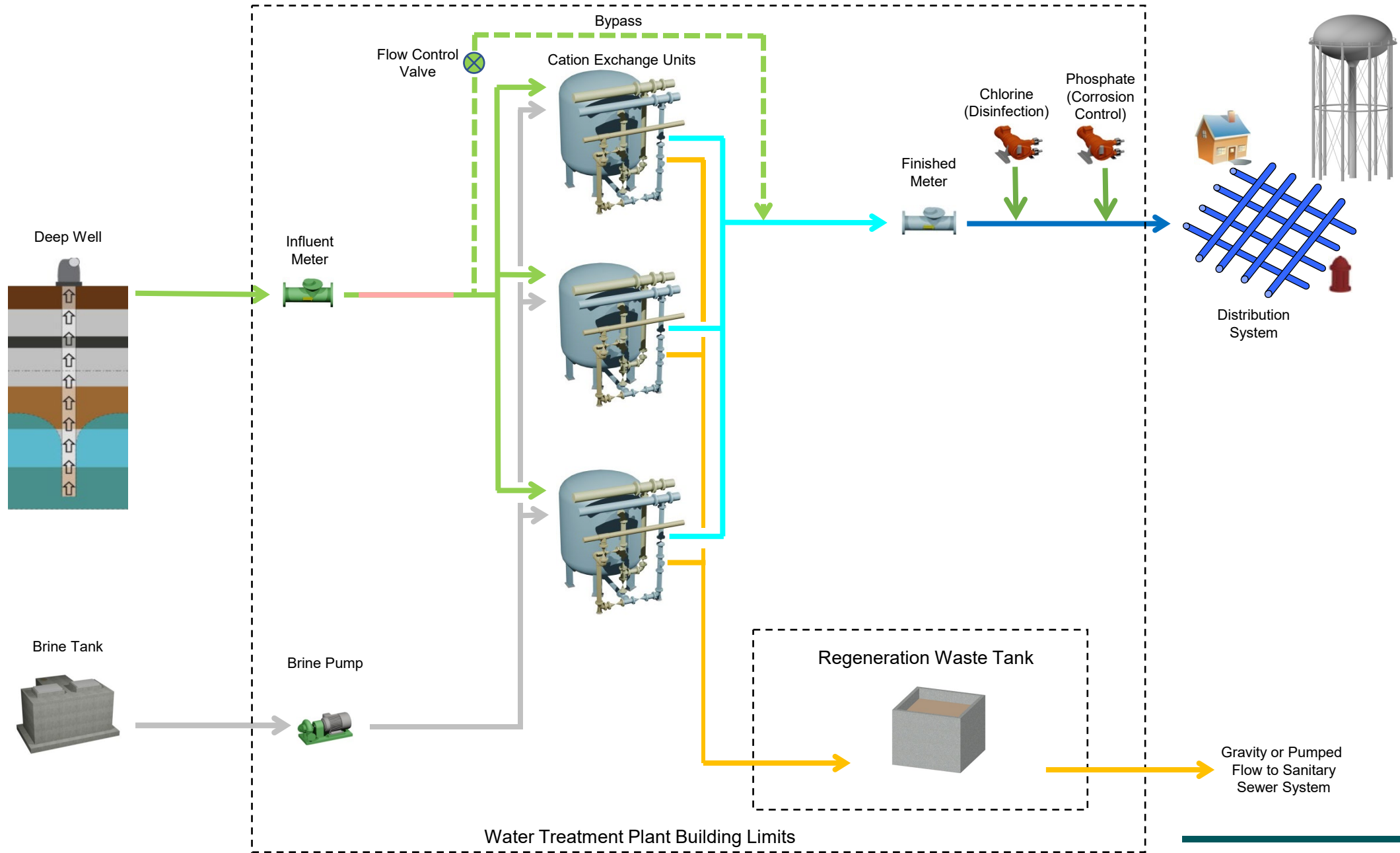

SUPPLY AND TREATMENT

- **North System Connection (2022):**
 - Well 7 & WTP Have Been Removed and Gast Rd. PRV Station Installed
- **Well No. 12**
 - Constructed 2008
 - Eau Claire & Mt. Simon Sandstone Formations
 - Depth of Well – 2,065'
 - Pump and Motor Installed – Has Not Been Operated Since 2008
 - No Treatment Constructed – Pilot Testing in 2009 Indicated Cation Exchange Treatment Viable, but must be Verified with Additional Testing
 - IEPA Has Recommended Abandonment, but Village Has Not Been Required to do so



WATER STORAGE

ELM ST EWST

500,000 Gallons
Constructed in 1996

ROUTE 20 EWST

500,000 Gallons
Constructed in 1998

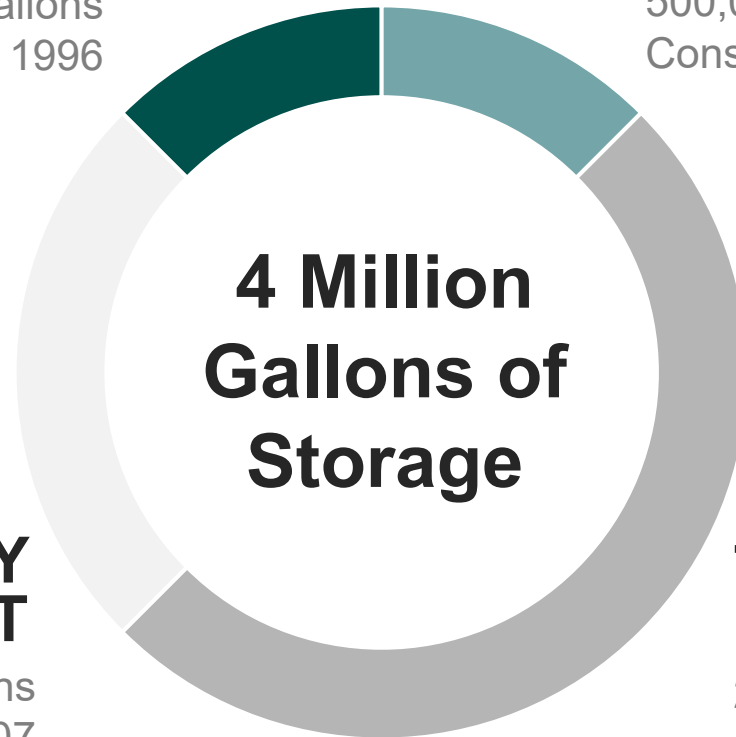

TUSCANY WOODS EWST

1,000,000 Gallons
Constructed in 2007

TAMMS FARM EWST

2,000,000 Gallons
Constructed in 2006

- Elm St EWST
- Route 20 EWST
- Tamms Farm EWST
- Tuscany Woods EWST



WATER DISTRIBUTION SYSTEM

- 58 Miles of Existing 4” – 16” Water Main
- Four (4) Pressure Zones
- Two (2) Distribution System Booster Pump Stations
- Six (6) Pressure Reducing Valves
- Critical Items
 - 14,000 Feet of 4” Water Main and 21,000 Feet of 6” Water Main
 - 8” Minimum is Current Industry Standard for Flow/Pressure
 - Approximately 11% of System 60-70 Years Old – Near End of Useful Life
 - Lead Service Line Inventorying and Replacements (Regulatory)
 - Update on LSL Inventorying



WATER WORKS SYSTEM MODELING

EXISTING WATER WORKS SYSTEM ANALYSIS

- No Significant Deficiencies in System Under Normal Conditions
- Potential for Slightly Lower / Higher than Ideal Pressures near Pressure Zone Boundaries
- Available Fire Flows Lower than Industry Standard in Downtown Area Due to 4" and 6" Water Main
- PRV Setpoints, Tamms Farm EWST, & Route 20 EWST Critical for Operations and Maintaining Adequate Pressures / Supply for Northern, Lakewood, and Brier Hill Service Areas Due to Lack of Water Main Looping

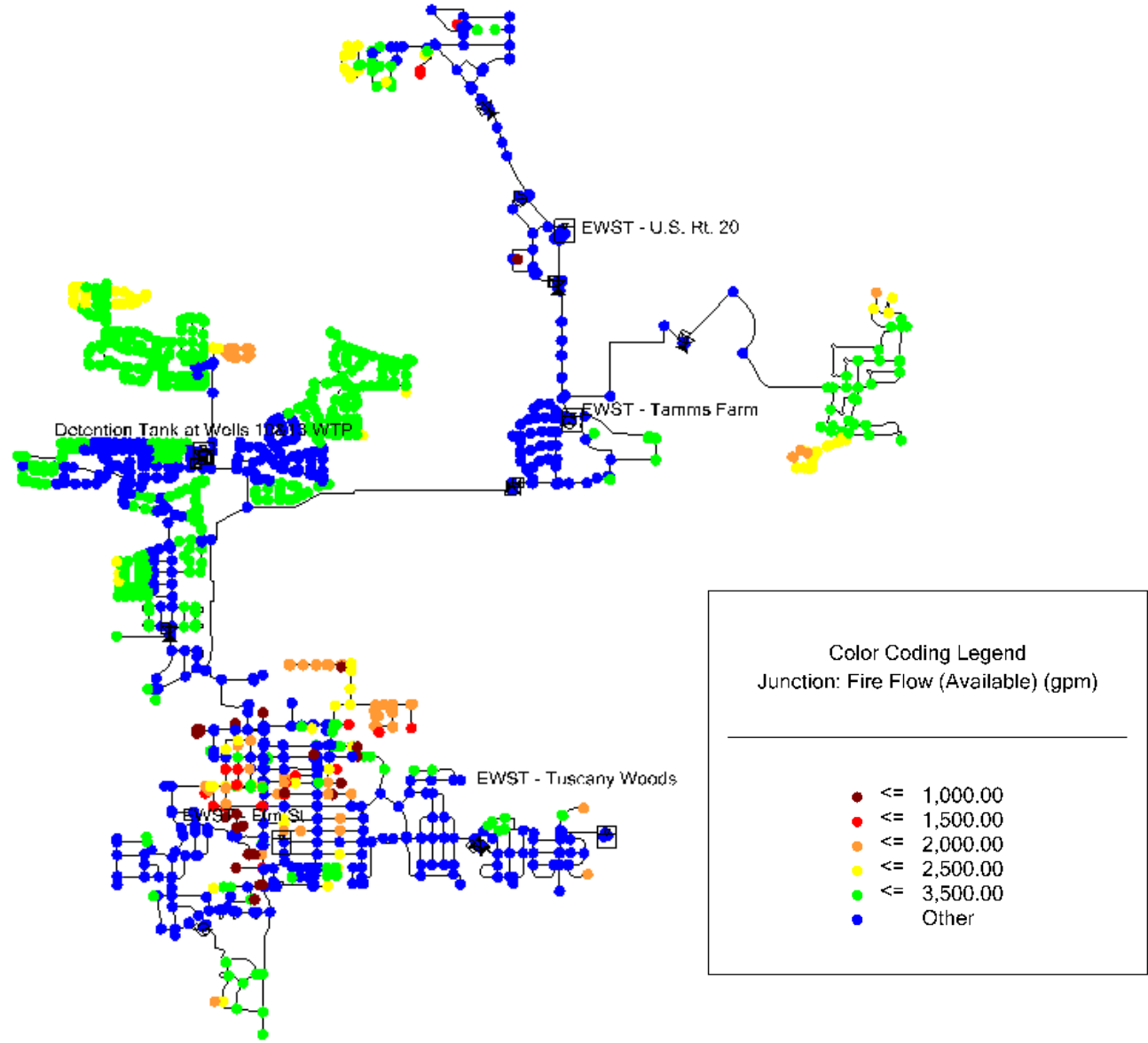

Regulation	Year Enacted	In Compliance?		Compliance Status
		Yes	No	
Safe Drinking Water Act (and Amendments in 1986 and 1996)	1974	☐		System is routinely monitored as required
Chemical Contaminant Rule, Phase I	1987	☐		System is routinely monitored as required
Total Coliform Rule (TCR)	1989	☐		System is routinely monitored as required
Lead and Copper Rule	1991	☐		System is routinely monitored as required
Chemical Contaminant Rule, Phase II & IIB	1991	☐		System is routinely monitored as required
Chemical Contaminant Rule, Phase V	1992	☐		System is routinely monitored as required
Unregulated Contaminant Monitoring Rule (Updated Every 5 Years)	1998	☐		System is routinely monitored as required
Stage 1 Disinfectant / Disinfection Byproducts Rule	1998	☐		System is routinely monitored as required
Radionuclides Rule	2000	☐		System is routinely monitored as required
Arsenic Rule	2001	☐		System is routinely monitored as required
Stage 2 Disinfectant / Disinfection Byproducts Rule	2005	☐		System is routinely monitored as required
Groundwater Rule	2006	☐		System is routinely monitored as required
IL Radium Treatment Residuals Rule	2011	☐		System is routinely monitored and reported as required
Revised Total Coliform Rule (RTCR)	2014	☐		System is routinely monitored as required
America's Water Infrastructure Act (AWIA)	2018	☐		System is in compliance
Revised Lead and Copper Rule	2021	☐		System is routinely monitored as required; Plans for service line replacement are underway
Radon Rule	Proposed			Proposed rule would set MCL at 4,000 pCi/L - or at 300 pCi/L without a Multimedia Mitigation Program to address radon in indoor air
PFAS Rule	Under Development	☐		Proposed Regulations: 4.0 ng/L for PFOS & PFOA, 1.0 Hazard Index for PFNA, PFHxS, PFBS, and Gen X

DRINKING WATER REGULATORY REVIEW

- In Compliance for All Applicable & Listed Regulations
- Lead and Copper Rule Revision Compliance Items are Currently Ongoing
- PFAS Rule Still Under Development but System Would Be In Compliance (No PFAS Detected or Anticipated)



EXISTING WATER WORKS SYSTEM

CONDITION AND CAPACITY FOCUS AREAS:

Tamms Farm Well (No. 12) Equipment (IEPA Violation)

Routine Maintenance – Well Rehabs, Softener Media Replacements at WTPs, EWST Cleaning/Painting; Electrical/Controls

No Permanent Backup Emergency Power Generators for Supply/Treatment (IEPA Violation)

Lack of Treatment Redundancy

Lead Service Line Inventorying and Replacements

Aging and Undersized Water Main

Water Pressures in Lakewood and Brier Hill Service Areas (Currently Addressing)



EXISTING WASTEWATER SYSTEM

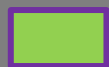
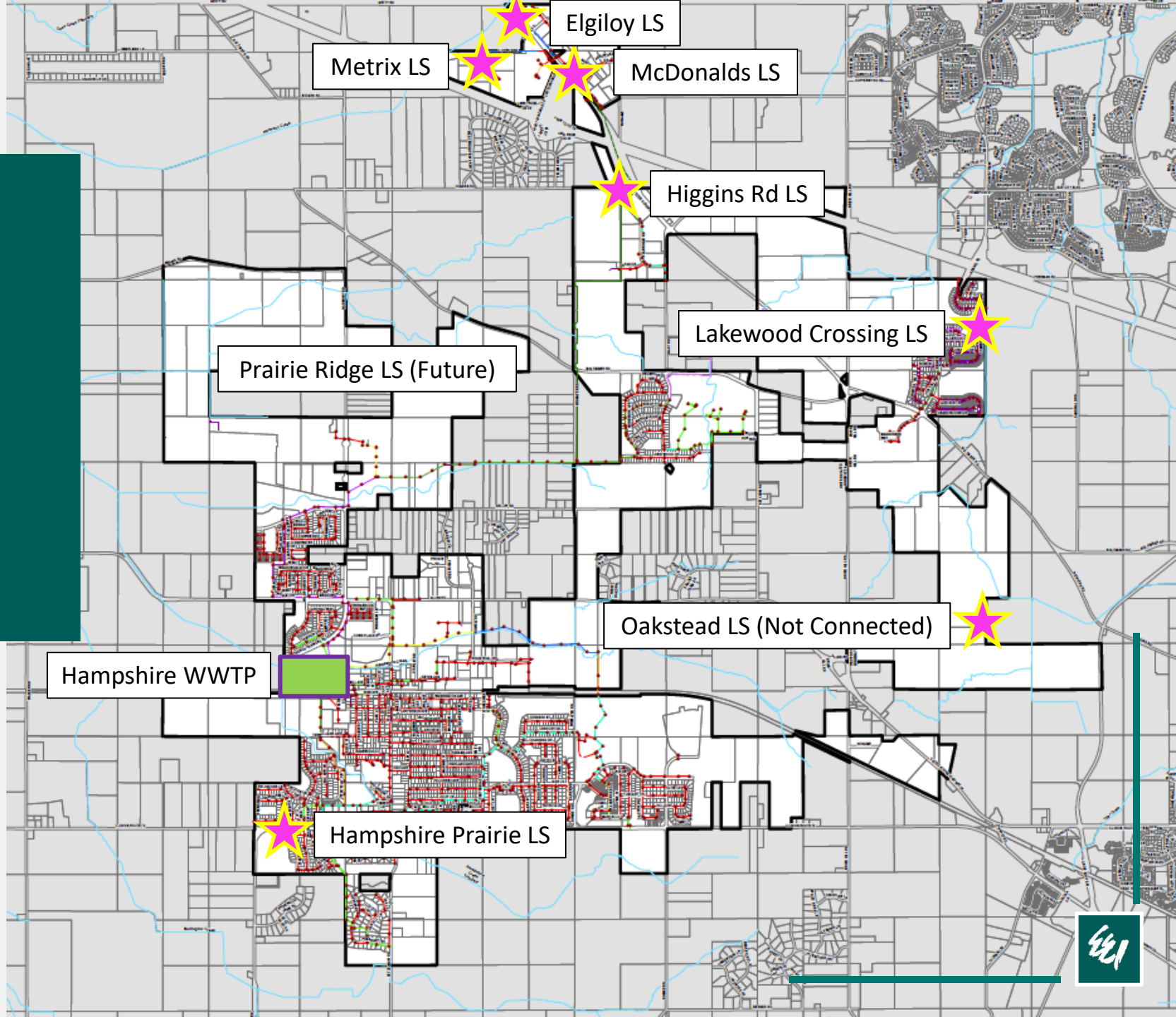

Treatment



Lift Station



WASTEWATER COLLECTION

- 45 Miles of 6” – 36” Sanitary Sewer
- Five (5) Lift Stations
 - 31,000 Feet of Force Main
- **Harmony Road Interceptor Service Area:** Serves North and Northeastern Development Areas
- **Hampshire Creek Interceptor Service Area:** Serves Southeastern Development Areas

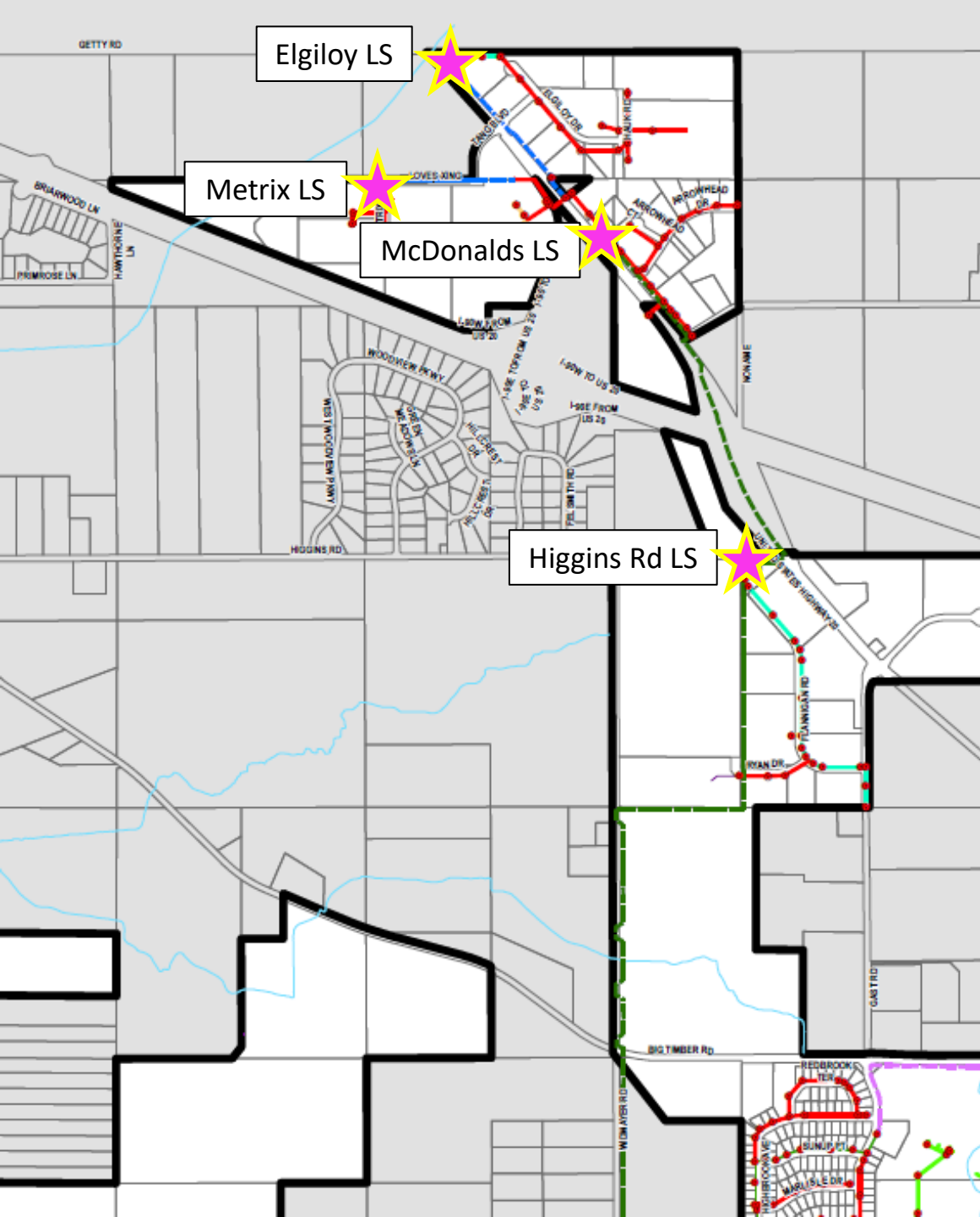

I-90 AREA:

- Served by Four (4) Lift Stations
- Three (3) Lift Stations Constructed in 1995
- Limited Capacity in Lift Stations to Service Future Developments
- Higgins Rd Lift Station Deteriorating
- Phasing of Improvements Dependent on Developments

HIGGINS ROAD LIFT STATION:

- Constructed in 1994
- Wet Well Walls and Piping are Severely Corroded
- Pumps are Undersized for Future Flow Conditions
- New Electrical Service, Control Building, and Generator Needed for Larger Pumps
- Complete Replacement Recommended



OAKSTEAD LIFT STATION:



- Constructed in 2008
- Infrastructure Installed, But Not Connected/Operational
- Will Require Significant Rehabilitation to Make it Operational – Particularly Electrical Equipment, Generator, and Controls

WASTEWATER TREATMENT



WASTEWATER PROCESS FLOW DIAGRAM

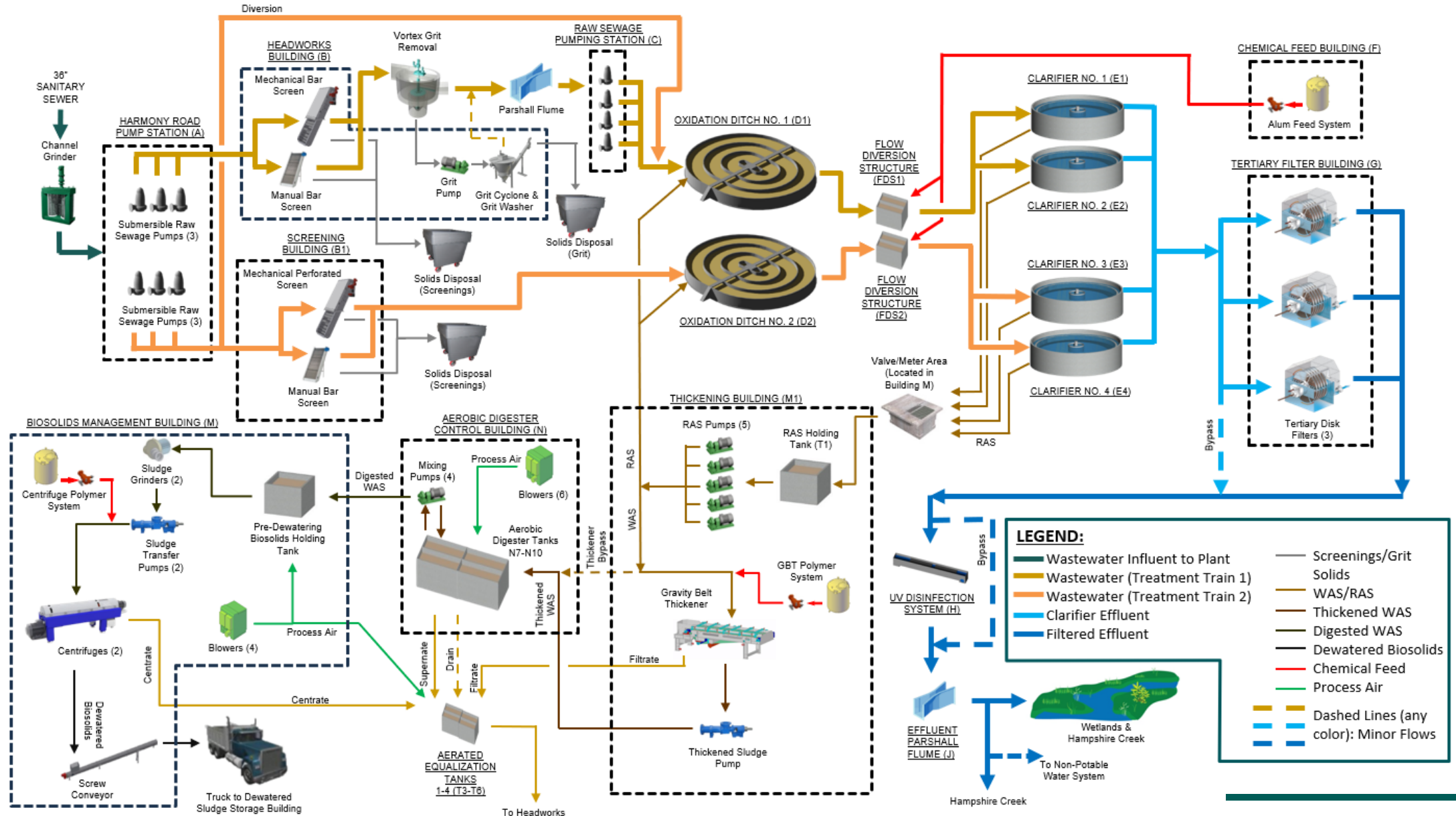

WASTEWATER TREATMENT HISTORY

- 2003 Expanded to 0.75 MGD Design Average Flow (DAF)
- 2008 Expanded to 1.50 MGD DAF with Addition of Third Ring to Oxidation Ditch No. 1
- 2010 Expanded to 2.76 MGD DAF with Addition of Second Treatment Train

Current Average Daily Flow: ~0.9 MGD



WASTEWATER TREATMENT

- Operation of Both Treatment Trains Has Never Been Required
 - Refurbishment of Existing Equipment in Unused Treatment Train Will Be Required in Preparation for Activation
- Piping and Screening Modifications for Operational Flexibility
- Existing UV Disinfection System is Obsolete and Must Be Replaced
- Challenges with Aerobic Digester Capacity Due to Increased Solids from Nutrient and Barium Removal
- Some Existing Equipment Reaching End of Useful Life – Dewatering Centrifuges, Electrical, Pumps



WASTEWATER REGULATORY REVIEW

- In Compliance with NPDES Permit and Existing and Near Future Wastewater Treatment Regulations
 - Typical Parameters
 - Barium
 - Total Phosphorus
- Total Phosphorus Effluent Limit of 1.0 mg/L (Current) and 0.5 mg/L (by 2030)
- Hampshire Creek on 303(d) List: Arsenic, Barium, Fluoride, Total Phosphorus
- Nutrient Assessment Reduction Plan (NARP) Ongoing

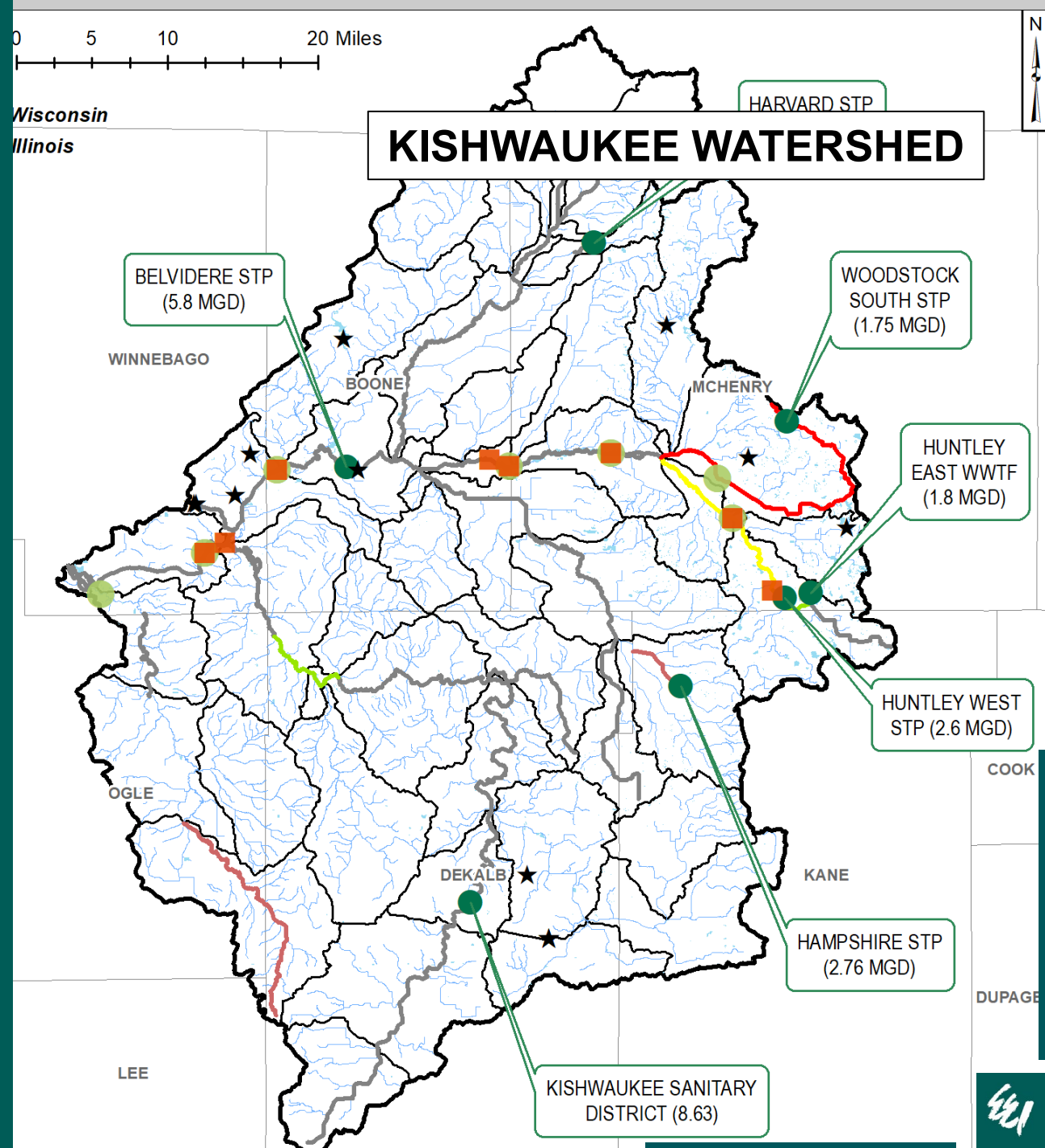

WASTEWATER SYSTEM

CONDITION AND CAPACITY FOCUS AREAS:

Higgins Road and Oakstead Lift Stations Improvements

Sanitary Sewer and Manhole Maintenance

WWTF: Biosolids Processes Capacity and Operations

WWTF: Screening System and Piping – Operational Flexibility

WWTF: 2nd Treatment Train

WWTF: UV Disinfection System

WWTF: Aging and Obsolete Existing Equipment



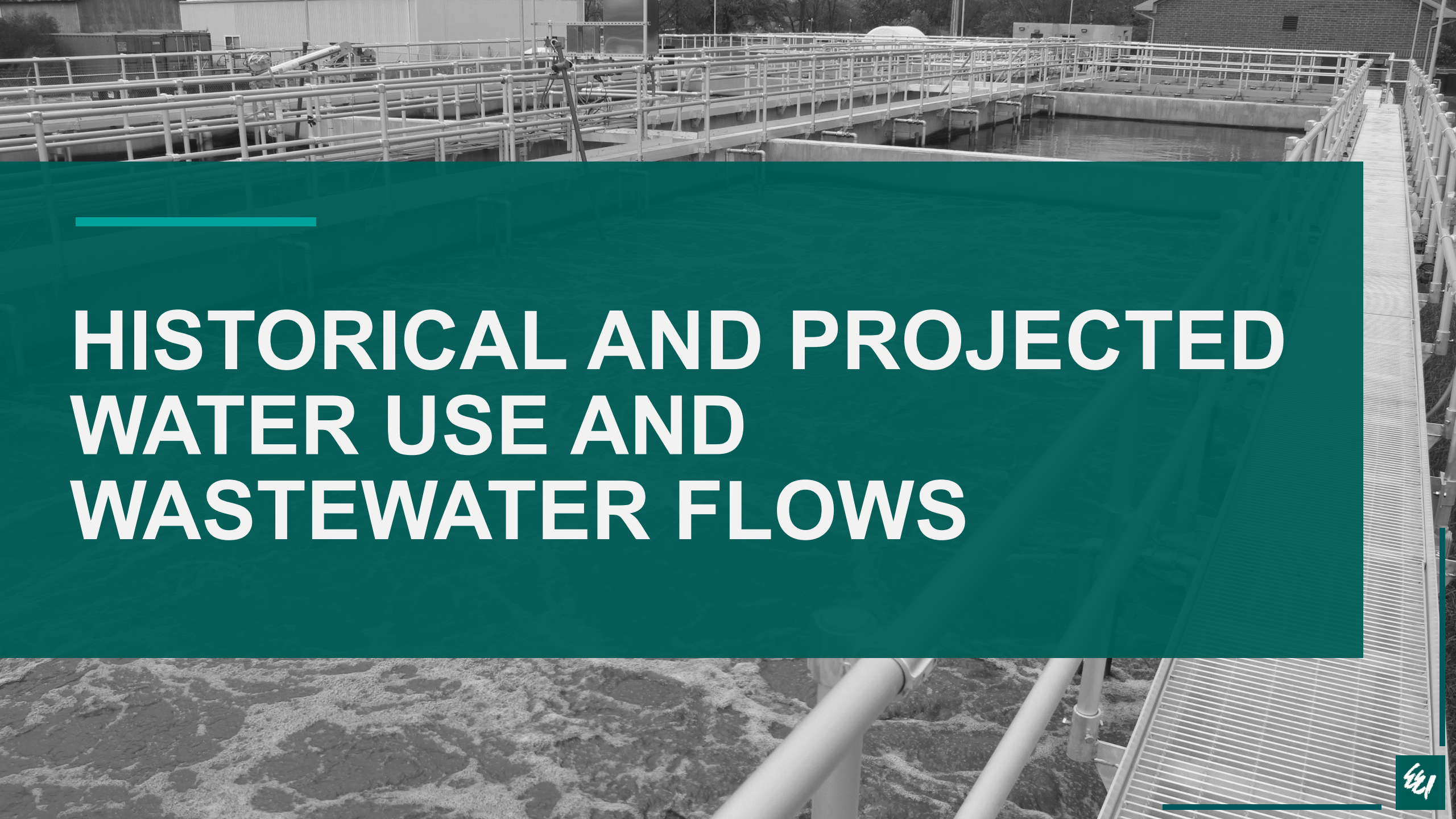

HISTORICAL AND PROJECTED WATER USE AND WASTEWATER FLOWS



POPULATION PROJECTIONS

- 3 Iterations of Population Projections Analyzed:
 - 2018 CMAP Projections,
 - 2022 CMAP Projections, and
 - Development-Based Population Projection
- Future Developments for Area North of I-90 also Analyzed for Population Equivalents Using Acreage, Projected Land Use, and Permit Applications if Available

Historical and Projected Population and Population Equivalents Growth
Village of Hampshire, IL

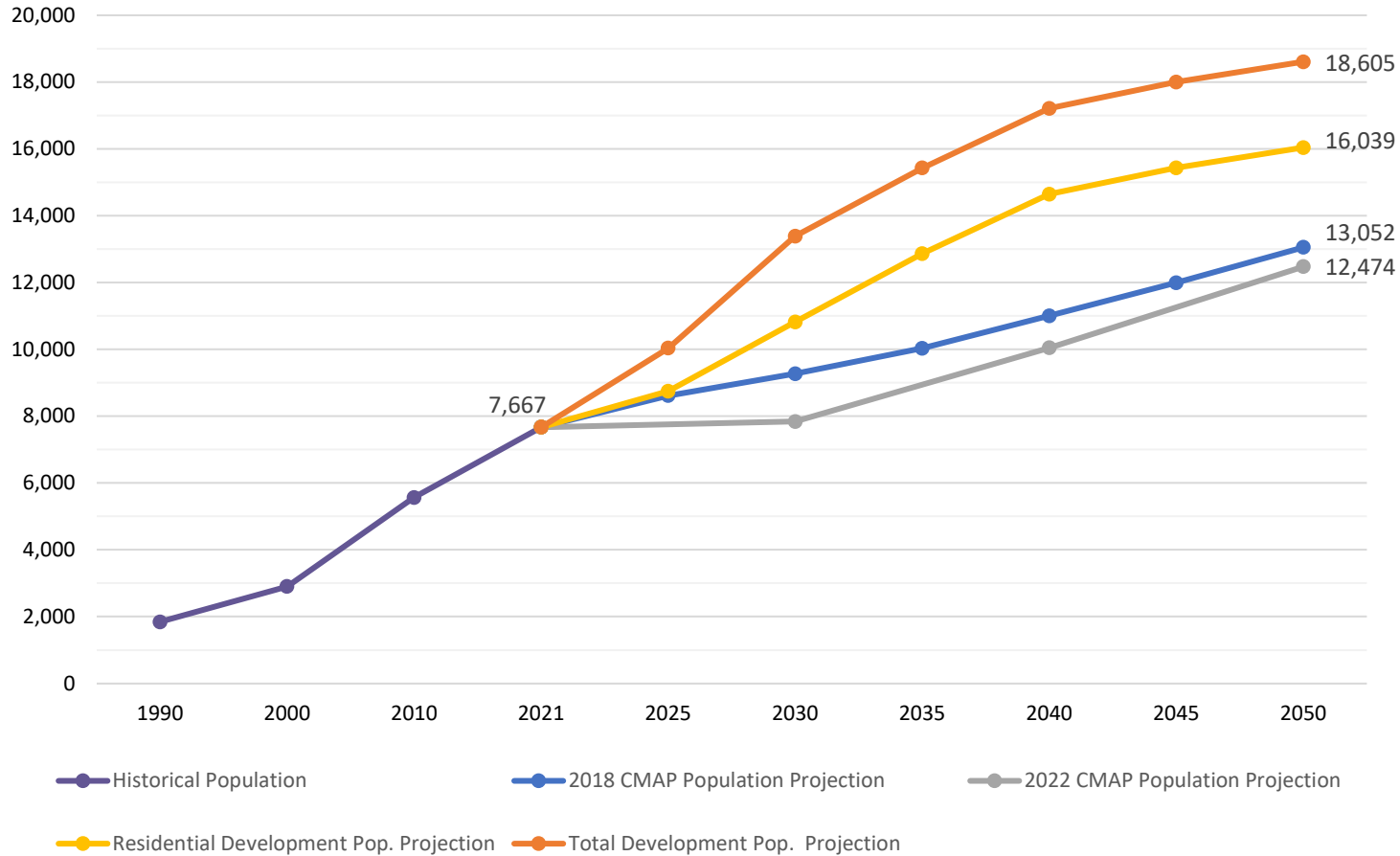

HISTORICAL AND PROJECTED GROWTH

- 2018 CMAP Projections Deemed Too Conservative
- 2022 CMAP Projections Deemed Too Conservative
- Residential Development-Based Projections Created with Staff Input
- Projected Population Equivalents Added for Northern Service Area



Historical and Projected Water Use Summary
Village of Hampshire, IL

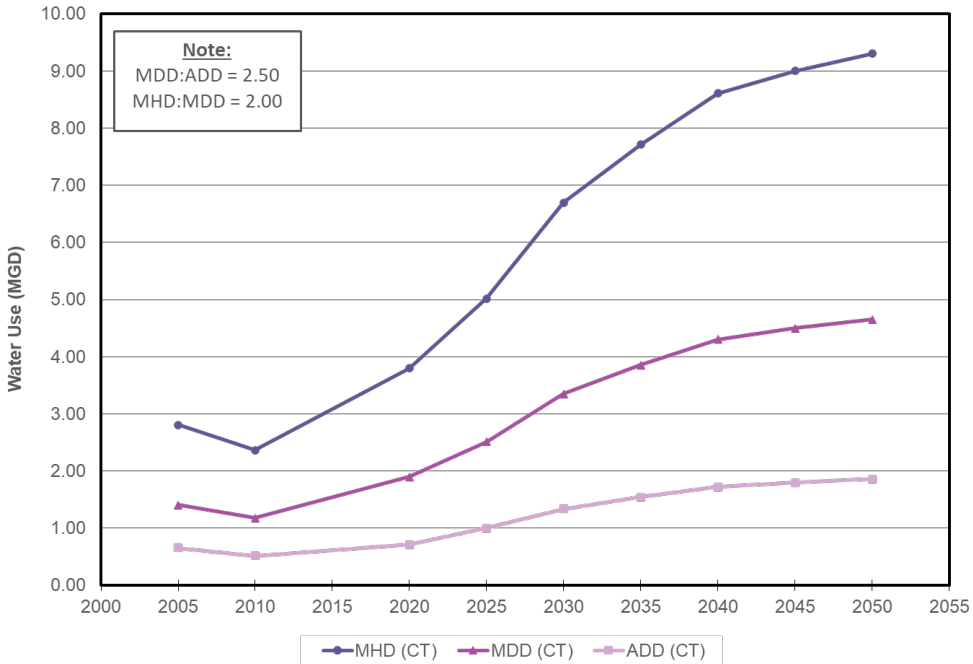

Average Daily Water Use - Baseline & Irrigation (2017 - 2021)
Village of Hampshire, IL

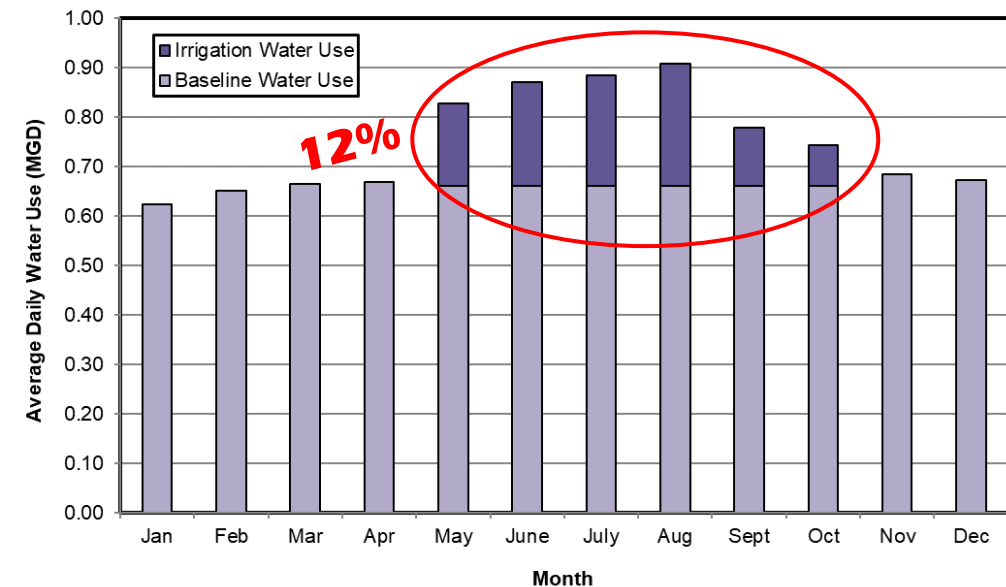

HISTORICAL WATER USE SUMMARY (2017-2021)

- Average Annual Pumpage: 275 MGD
- Average Daily Demand: 0.75 MGD
- Maximum Daily Demand: 1.83 MGD
- Current Use: 101 GPCPD
- MDD:ADD: 2.45

2050 WATER USE PROJECTION

- Annual Pumpage: 679 MGD
- Average Daily Demand: 1.86 MGD
- Maximum Daily Demand: 4.65 MGD
- Projected Use: 100 GPCPD
- MDD:ADD: 2.50



WASTEWATER FLOWS

- **Historical Flows (2017-2021):**
 - 0.91 MGD Average Daily Flows
 - 2.28 MGD Maximum Daily Flows
- **2050 Projected Flows:**
 - 2.01 MGD Average Daily Flows
 - 5.01 MGD Maximum Daily Flows
 - Projected Need for Second Treatment Train to be Operational by 2030, but Expansion of WWTF is Not Needed in Planning Period

Wastewater Flow Projections against WWTF Capacities Using Development Projections
Village of Hampshire, IL

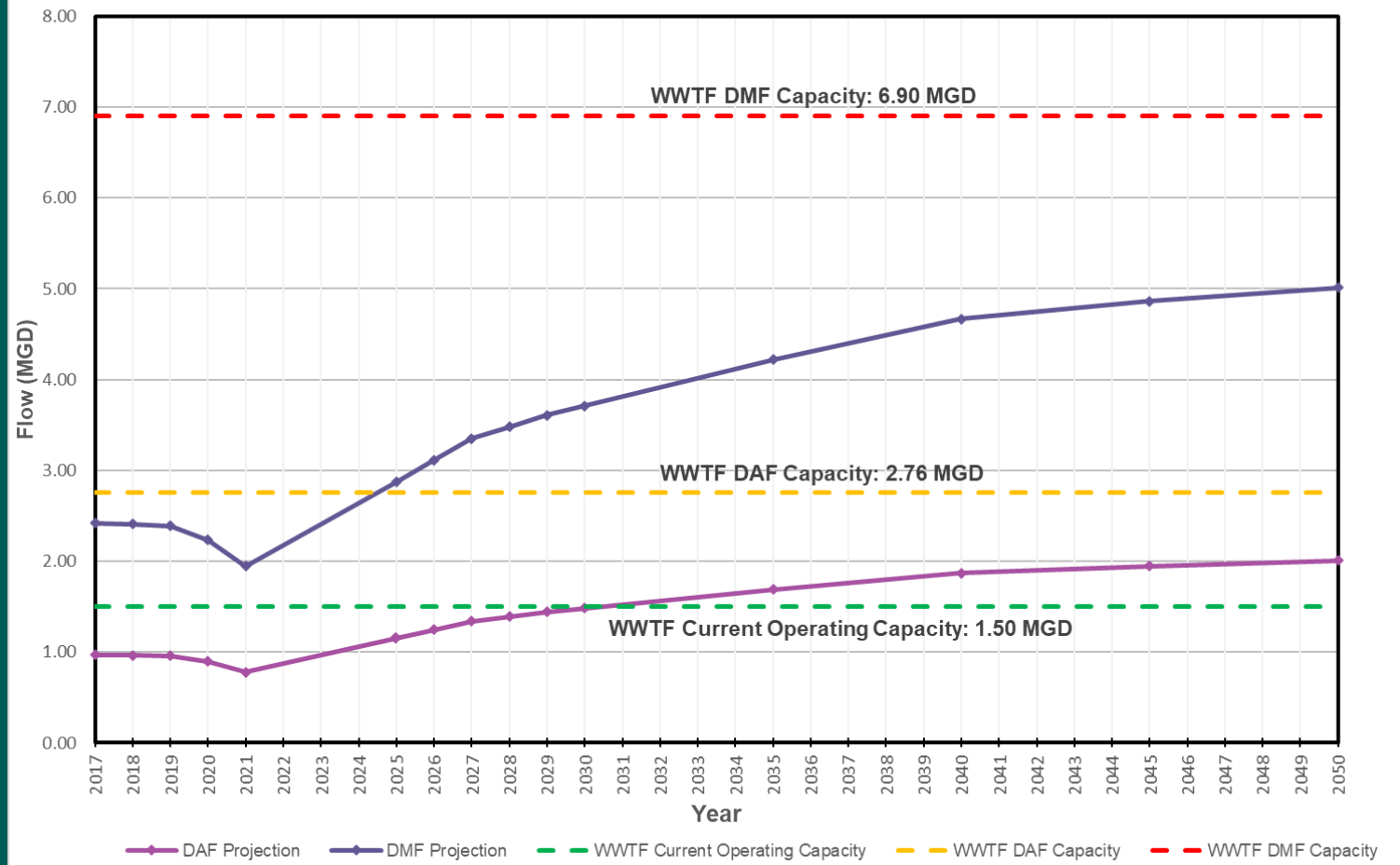



INFILTRATION & INFLOW ANALYSIS (2017 – 2021)

- Calculated by Subtracting Adjusted Potable Water Use (Estimated Distribution Losses & Irrigation Use) from Influent to the WWTF

- 2017-2021 Average I&I Percentage of Total Wastewater Flow: 30.7%

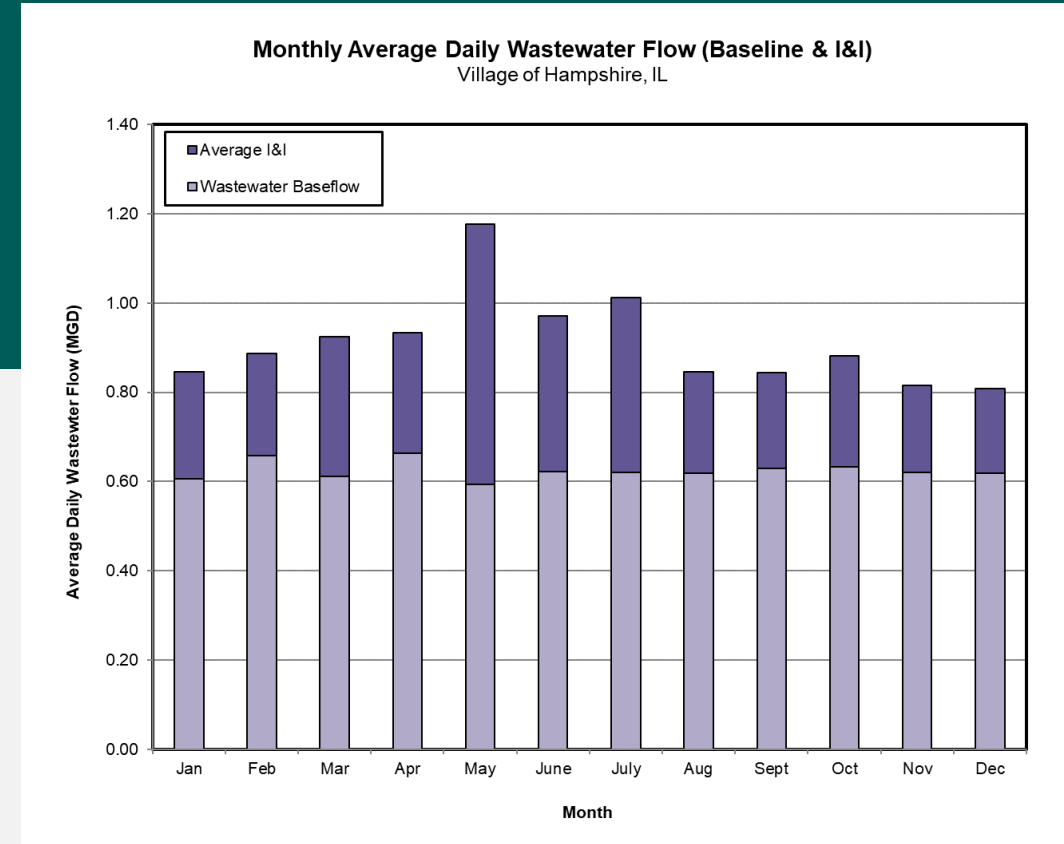
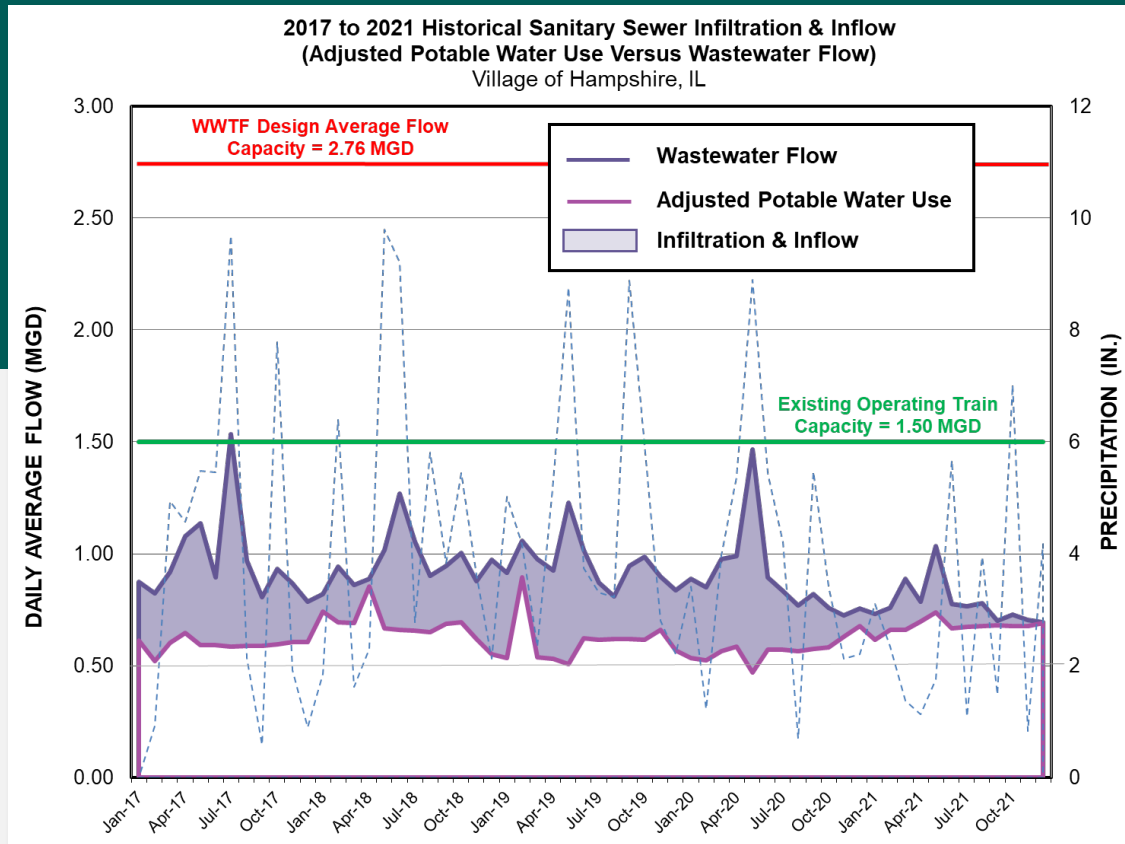
2021 I&I Percentage: 14.2%





WATER SYSTEM EVALUATION AND RECOMMENDATIONS

WATER SUPPLY & TREATMENT NEEDS ASSESSMENT CALCULATIONS

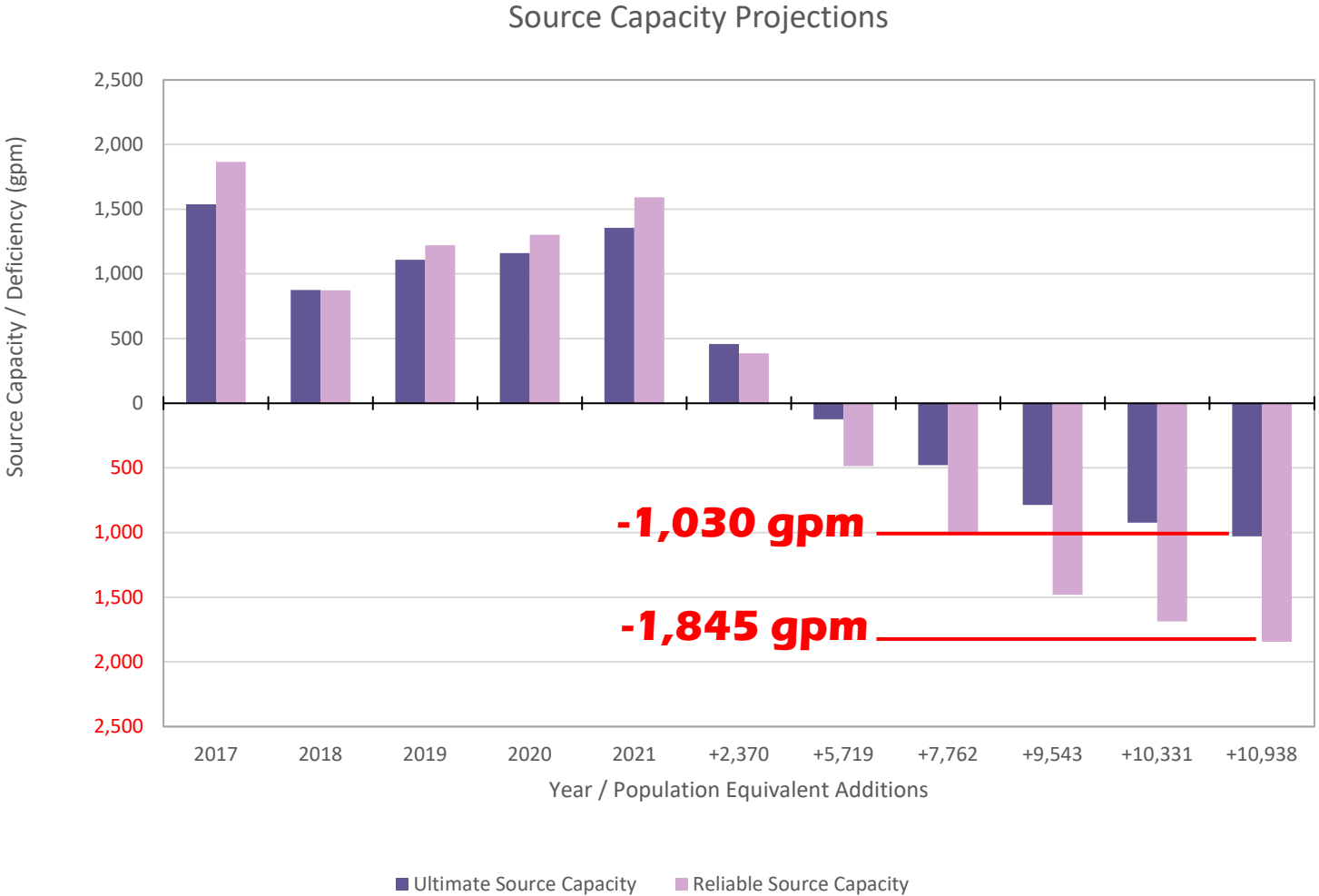

- Ultimate Source Capacity
 - Negative at +4,299 Population Equivalents, Currently Est. in 2028
- Reliable Source Capacity
 - Negative at +3,520 Population Equivalents, Currently Est. in 2026 – Requires Well 12 & WTP
 - New Well 14 – Currently Est. by 2034



Storage Capacity Projections

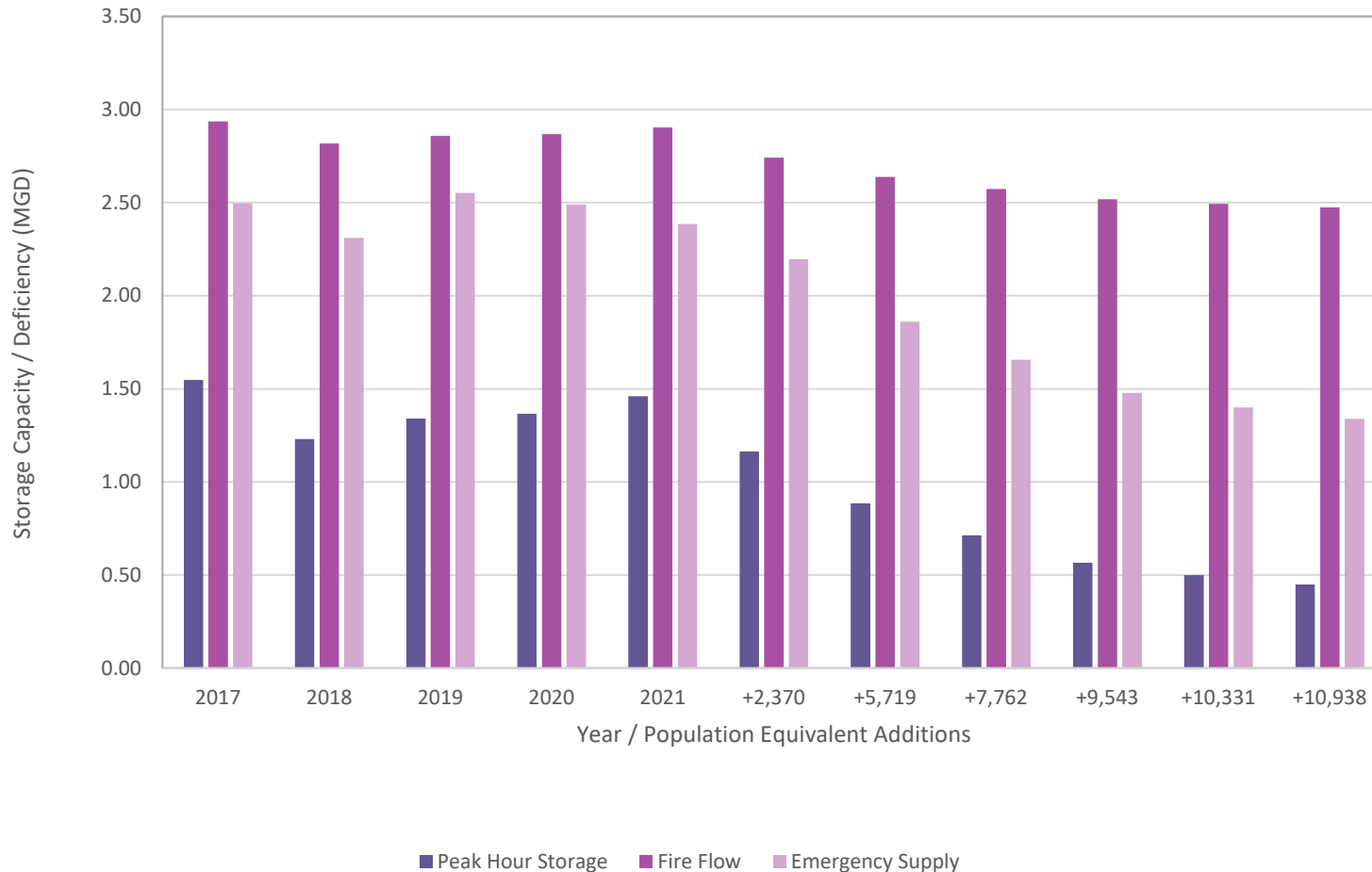







WATER STORAGE NEEDS ASSESSMENT CALCULATIONS

- Peak Hour Storage
- Fire Flow Storage
- Emergency Supply
 - Due to Lack of Emergency Power Capabilities at the WTPs, this Parameter was Assessed Solely on Storage Volume

Storage Facilities are Adequate for All Test Parameters



WATER WORKS SYSTEM MODELING

Color Coding Legend	
Pipe: Diameter (in)	
	4.0
	6.0
	8.0
	10.0
	12.0
	16.0
	Other

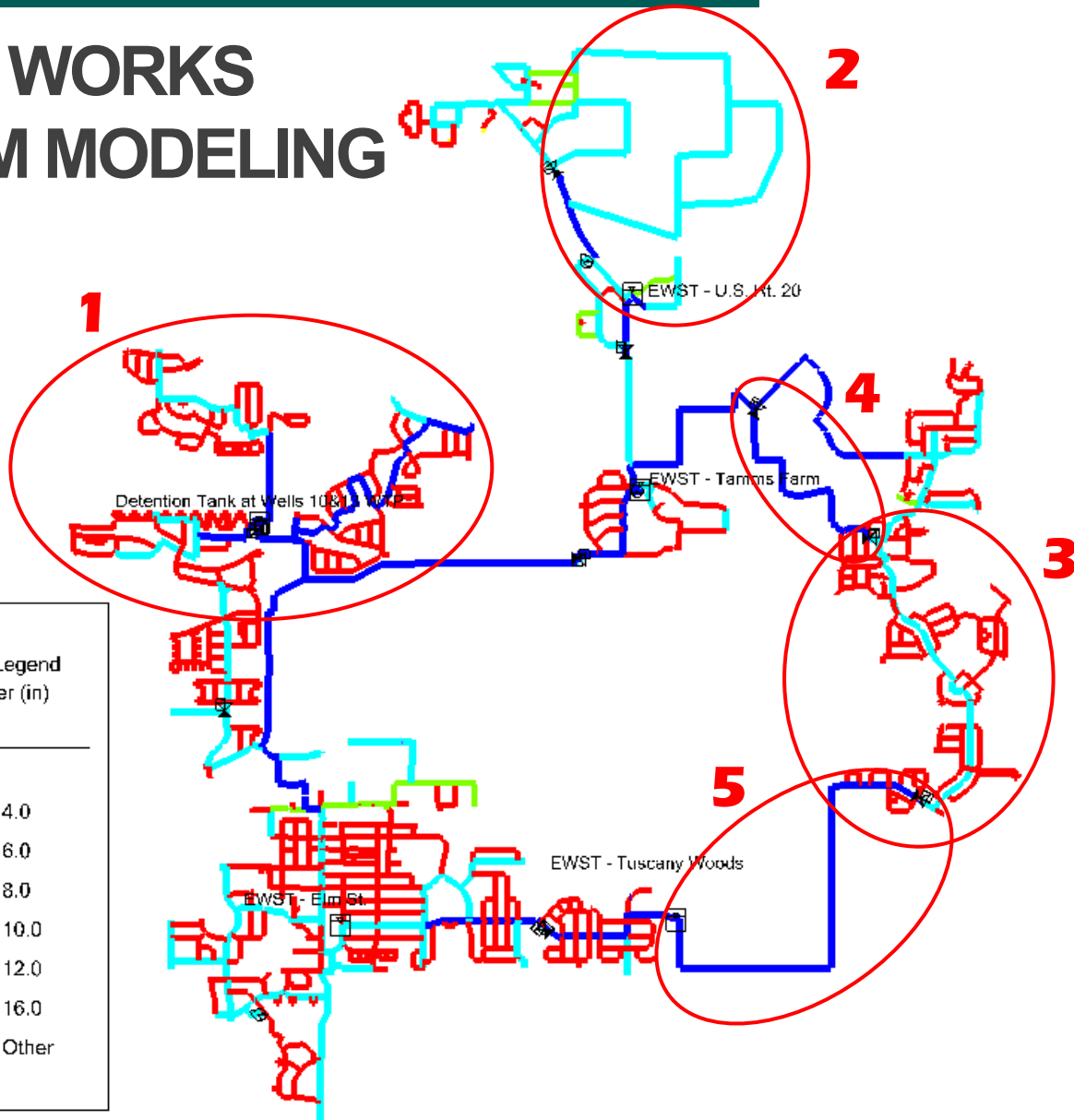

FUTURE WATER WORKS SYSTEM ANALYSIS

Future Developments / Water Main Improvements Grouped into Phases Based on General Anticipated Order of Completion

1. Prairie Ridge North
2. Northern Service Area
3. Oakstead
4. Northeast 16" Water Main Loop Between Brier Hill PRV & Oakstead Subdivision (Developer)
5. Southeast 16" Water Main Loop Between Oakstead & Tuscany Woods (Developer)



FUTURE WATER WORKS SYSTEM ANALYSIS

- Prairie Ridge Proposed Plan Provides Acceptable Pressures
- Northern Service Area May Need System Separation Valves at Pressure Zone Boundaries
- Much of Oakstead Subdivision Would Have Suboptimal Pressures and Available Fire Flows Without Both 16" Water Main Loops
 - Booster Pump Station Not Viable
 - Just One Water Main Loop Would Still Leave Areas of Low Pressures and Available Fire Flows
 - Both 16" Loops Best Option
- 4" and 6" Water Main Replacement Recommended as Time/Budget Allows

WATER WORKS SYSTEM MODELING

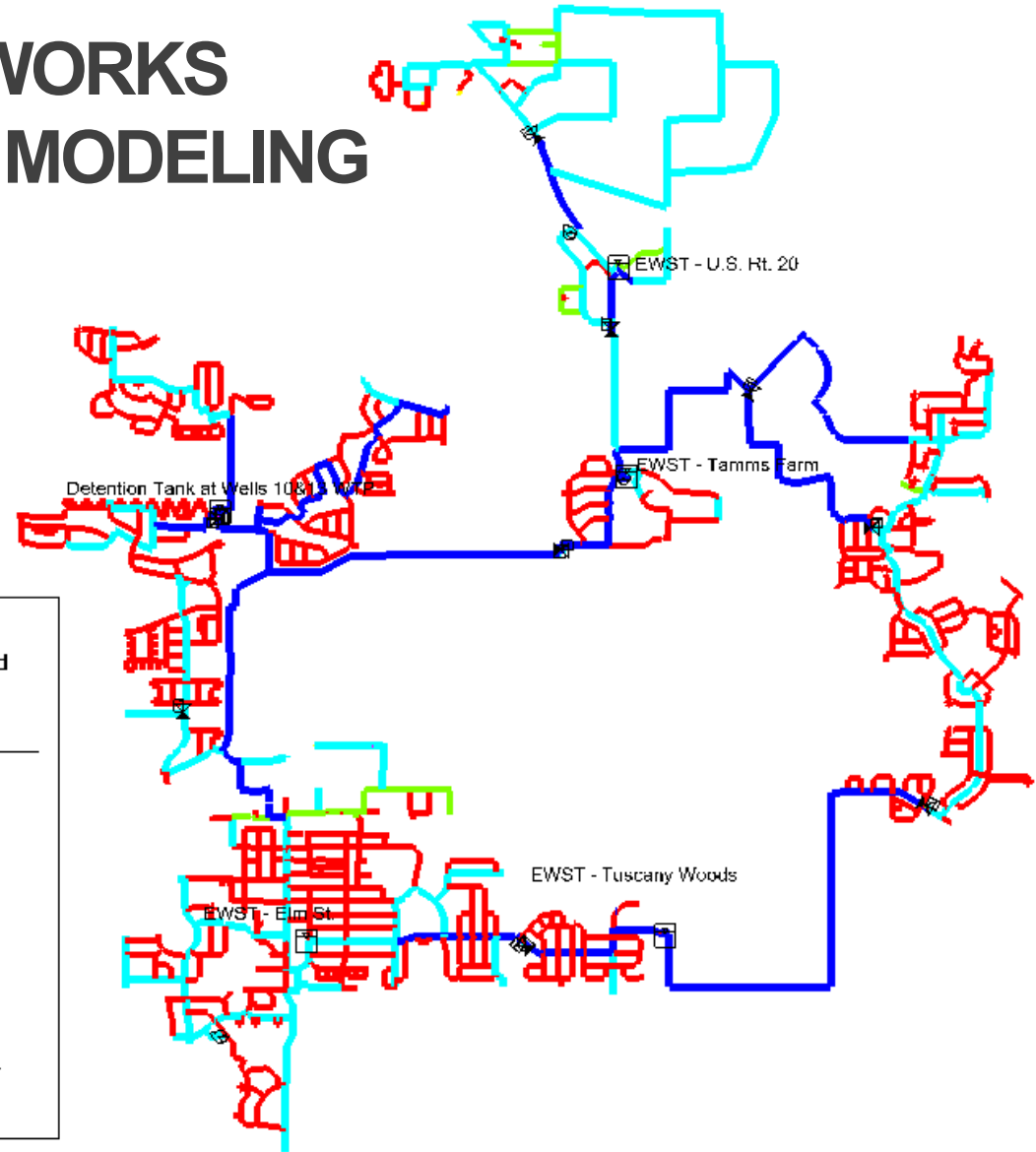
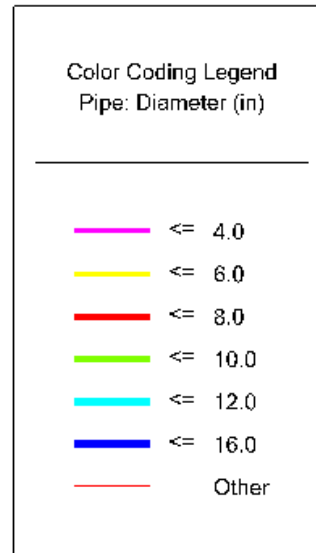



WASTEWATER SYSTEM EVALUATION AND RECOMMENDATIONS



WASTEWATER COLLECTION & CONVEYANCE IMPROVEMENTS

- Higgins Rd Lift Station Replacement
- McDonalds Lift Station Replacement
- Oakstead Lift Station Rehabilitation
- Sewer Lining and Manhole Rehabilitations

WWTF IMPROVEMENTS

- Oxidation Ditch No. 1 Rehabilitation – Comprehensive
- Secondary Clarifiers No. 1 & 2 Rehabilitation – Comprehensive
- Oxidation Ditch No. 2 Rehabilitation – Routine
- Secondary Clarifiers No. 3 & 4 Rehabilitation – Routine
- Modify Diversion Chamber to Allow Use of Either Set of Secondary Clarifiers
- Force Main Revisions to Screening Building to Increase Pumping Capacity
- Piping Revisions to Oxidation Ditches – Operational Flexibility
- Replace Raw Sewage Pump Station Pumps No. 1-4



WWTF IMPROVEMENTS (CONT.)

- Replace Aging and Obsolete Ultraviolet (UV) Disinfection System
- Biosolids Dewatering Centrifuge Replacements
- Digested Sludge Pump Replacement
- Replace Harmony Road Raw Sewage Pumps No. 1, 2, & 3
- Additional Mechanical Bar Screen in Screening Building
- Additional Aerobic Digesters and Digester Cover Replacements
- Replace Obsolete and Failing Electrical and Controls Equipment



GENERAL WATER AND WASTEWATER SYSTEMS CHALLENGES

- Systems are Geographically Spread Out – Long Distance Connections = More Infrastructure to Maintain – Piping, Pump Stations, etc.
- Some Infrastructure Currently Oversized – Requires Maintenance of Some Components Not Utilized or Underutilized (i.e., WWTF)
- Significant Infrastructure Constructed Between 2002-2008 – 20-Year Life Cycle Components Reaching Conditions Requiring Rehabilitation or Replacement
- Older Infrastructure Reaching End of Useful Life (Watermain, Sewers/Manholes – Require Rehabilitation or Replacement)