

Meeting Agenda  
Business Development Commission  
May 13, 2020 6:30 p.m.  
(Virtual Meeting)

1. Call to Order
2. Public Comments
3. Review of the March 11, 2020 minutes for approval
4. Brochure Discussion
  - A. Update (Reid)
5. Chamber Update (Mayer)
6. Main Street
  - A. Presentation of the third set of seminars (Thomas)
    - i. How can we help business now?
  - B. Presentation of the fourth set of seminars (Pizzolato) – Delayed till June Meeting
  - C. Formation of Main Street Committee – Next Steps
    - i. Review feedback (please send) from committee
7. Update on the Revolving Loan Fund
  - A. Street Walkthrough (Thomas/Lamp/Swalwell)
  - B. Review of Concept Plan Proposal
8. Beautification Committee Report
  - A. Façade updates (Swalwell)
    - i. Faithway Baptist Application Review and Vote
  - B. Update on wayfinding refinement progress (Swalwell)
  - C. Beautification Meeting Report (anything else?)
9. Budget update
  - A. Façade Program - \$75,000
10. Update on Administrative Adjudication (Hedges)
11. Hampshire's Very Own
  - A. List of remaining companies
    1. Incredible Builders (completed)
    2. Rose Garden
    3. Moffett Physical Therapy
    4. Vintage Hammer
  - B. (Luxor Nails – completed/delayed)
12. Update on new or existing businesses in the village
  - A. Elegant Outdoor Designs – Brian Awad
13. Adjourn

Attendance: By Executive Order of the Governor, No. 2020-10 and No. 2020-18, all public meetings and public hearings for essential governmental services through May 30, 2020, maybe held by video or teleconference, provided there is an accommodation for the public to participate, and submit

questions and comments prior to meeting. If you would like to attend by Video or Tele Conference, you must e-mail the Village Clerk with your request no later than 24 hours prior to the meeting and a link to participate will be sent to your e-mail address the day of the meeting, including all exhibits and other documents (the packet) to be considered at the meeting.

Public Comment: Comments or questions may be submitted to the Village Clerk no later than 4:00 PM on the day prior to the meeting, by e-mail to [Lvasquez@hampshireil.org](mailto:Lvasquez@hampshireil.org). Any written comments so received shall be noted in the minutes of the meeting.



Business Development Commission  
Meeting Minutes  
March 11, 2020 6:30 p.m.  
Hampshire Village Hall

Call to order at 6:30 pm

Present: Commissioners Bill Swalwell, David Pizzolato, Elaine Thomas, Susie Kopacz and Trustee Ryan Krajecki

Absent: Ian Lamp

Also, in attendance was Village Administrator Hedges, Village Intern Josh Wray and Jeanie Mayer from the Hampshire Area Chamber of Commerce

**Public Comments:**

- None

**Meeting Minutes Approval From 2/12/20:**

- Commissioner Pizzolato moved to make a motion to approve the 2/12/20 meeting minutes.
  - Second by Commissioner Kopacz
  - Motion carried by voice vote:
    - Ayes: Swalwell, Pizzolato, Thomas, Kopacz and Krajecki
    - Nays: None
    - Absent: Lamp

**Introduction of Josh Wray**

- Village Administrator Hedges introduced Josh Wray as the new Village Intern that will be working on Village projects as he completes his graduate degree at Northern Illinois University.

**Marketing Brochure Update**

- Jeanie Mayer discussed that the PR Commission is working directly with the printer to develop a 1st draft for review in the coming months. Commissioner Kopacz shared a local resident who may be able to provide updated images for the brochure.

**Main Street Program**

- Commissioner Swalwell presented a review of the course: Advance Principals: Quality Design - Commissioner Swalwell. Though there were many takeaways, the main ones included self-assessments of existing districts and people come first in design, cars second. He will take these learnings to the Beautification Committee for further review.
- Village Intern Wray reviewed other communities and shared both the similarities of such boards, along with pros/cons.
- The BDC discussed if we should propose building another committee to focus on Main

Street initiatives, roll it into the Beautification Committee, remain under the BDC with a meeting two times a month or other scenarios. The Commission should think about the proposal and be prepared to discuss during April's meeting.

### **Intersect**

- Village Administrator Hedges discussed that both he and Village Intern Wray met with the DECO representatives for insight into best practices of engaging through state-level resources. More updates, including potential properties that live on the website will be brought to the BDC for review prior to their listing.

### **Beautification Committee Report**

- Commissioner Swalwell presented the following updates to the façade program.
  - Speckled Fawn – Commissioner Swalwell continues to help bring progress to the project, but work remains at a standstill and the Committee is still awaiting a formal application to be submitted.
  - Faithway Baptist Church - They are considering filling an application to update their facade with more to come.
  - Bassett Hound Rescue – Progress has already begun on the building and the improvements are very welcomed by the Commission.
- Commissioner Swalwell updated the BDC that there currently are bids out for updating the wayfinding signage throughout the Village.
- Jeanie Mayer discussed that the Chamber is currently getting quotes to update the sign at the NE corner of Main St. & Rt. 72 to an LED sign. The BDC was very encouraged and pleased that an updated sign is in the works.

### **Revolving Loan Fund Update**

- Village Administrator Hedges discussed that two projects may potentially allow the Village to use funds that are currently being held in a Revolving Loan Fund. One is for a project with the residents on Highland Ave. to resolve their flooding issues and the other to invest in streetscape enhancements on Main St. An update will be given at the April BDC meeting.

### **Administrative Adjudication Update**

- Village Administrator Hedges discussed the Beautification Commission's request and need for a code enforcement program within the Village. The BDC feels strongly that this is important to have in place as the group continues to invest within the Village. The Village currently has an adjudicator on staff and the BDC's next step is to present a list of exterior elements that it feels need to be enforced. These are to be presented during April's BDC meeting.

### **Hampshire's Very Own**

- The BDC decided due to time constraints, the current schedule of Hampshire's Very Own articles be pushed back by one month as follows:

1. Luxor Nails (March)
2. Incredible Builders (April)
3. Rose Garden (May)
4. Moffett Physical Therapy (June)
5. Vintage Hammer (July)

#### **New or Existing Business Update**

- No update

#### **Adjourn**

- Commissioner Pizzolato moved to make a motion to adjourn at 8:52
  - Second by Commissioner Swalwell
  - Motion carried by voice vote:
    - Ayes: Swalwell, Pizzolato, Thomas, Kopacz and Krajecki
    - Nays: None
    - Absent: Lamp

PLAN DETAIL

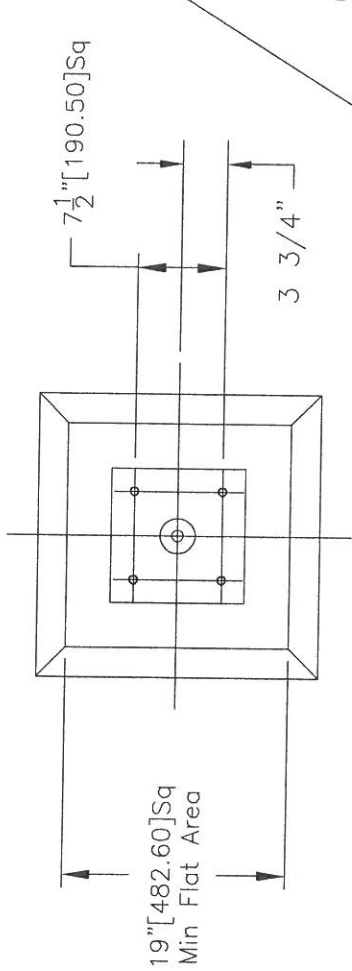

NOTE: 1ST PLATE TO BE 6" FROM BOTTOM AND 2ND PLATE 24" FROM BOTTOM. MAKE SURE ANCHOR RODS ARE 7-1/2" ON CENTER AND PERPENDICULAR TO GRADE AFTER POURING

If mounting indoors on existing concrete slab, use 5/8"x5"Lg Concrete Bolts, 2-3/4" min. embedded depth (McMaster Carr #92405A402)

Clock Face →

(4) 5/8" [15.88]  $\phi$  Rods  
36" [914.40] Long Steel

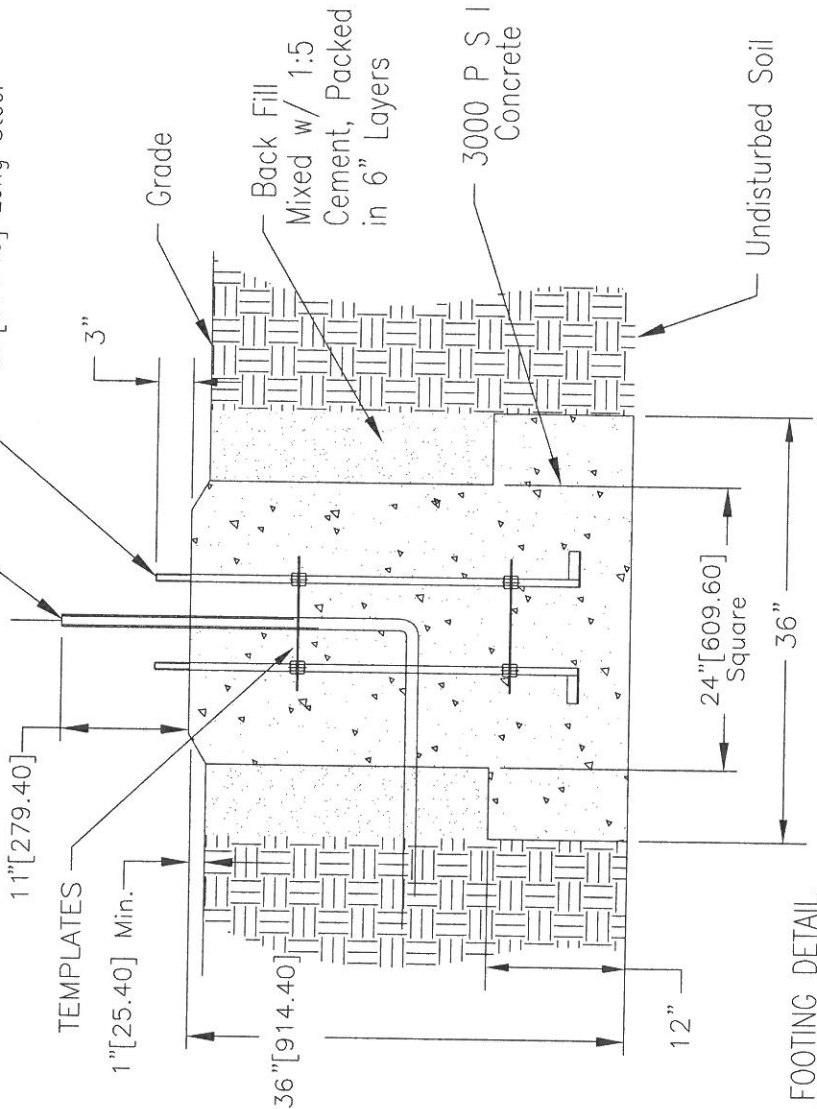

FOOTING DETAIL

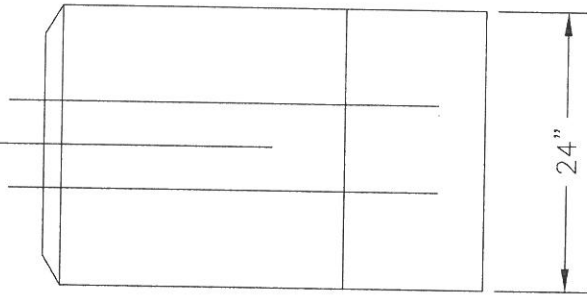

SIDE ELEVATION

PATH	D:\ACAD10\A-5095.DWG		
TITLE	Small E. Howard Post Foundation Detail		
APP'V	TDE	DATE	4-29-94
DRAWN	RK	SCALE	3/4" = 1'
REV. A	10-12-94	REV. B	10-10-95
REV. C	10-10-96	REV. D	3-22-02
REVISIONS DMC DMC WOR			
electric time company, inc medfield, ma			
VIEW	DRAWING A-5095		

## Request for Proposal

**Project:** Street Scape on State

**Background:** The Village of Hampshire has \$1.1 million set aside from the CDBG Close Out program. The Village Board and Business Development Commission have decided to use this money for a street scape project on State St. extending from Jackson Ave. north to Keyes Ave.

**Proposal Requirements:** In order to submit a grant application for the \$1.1 million, the Village must submit a concept plan detailed enough to generate cost estimates. Input given during the meeting on April 21 provide the scope of the project. Requirements for the concept plan include:

- A simple rendering of the landscape plan and changes to lighting, signage, and surface improvements
- A description of the impacted area
- A project budget that includes design, materials, and labor costs in enough detail necessary to provide a reasonably accurate total cost

**Submission Timeline:**

- Due by May 1, 2020
  - One-page statement of qualifications
  - Additional input/information needed from the Village
  - Quote to create concept plan
- Due by June 1, 2020
  - Concept plan

## Trustee Krajecki's Comments (Chair of BDC)

1. Do lights and signs stay or go? We have discussed over the years that there are two types of lighting for Main Streets. The first is way overhead and is designed specifically to give the appropriate amount of light to assist cars while driving. The other type as I understood is to be more decorative and is aimed at pedestrians. We certainly understand that we cannot effect the ability of drivers to see while driving through our busiest pedestrian area, so whether that means leaving the relatively unattractive upper lighting while adding more decorative lower lighting or coming up with an approach where new light poles can effect both I am ok with it. We would just like to have lighting be a focus with an aim at creating a more walkable space and having the light poles themselves add to the aesthetic.
2. Planters? Of course the look of planters and foliage is a great idea because it adds to the look and feel of downtown. We have to recognize that planters are difficult to maintain due to the labor required for initial springtime maintenance and routine watering. I am for the notion of having foliage in the downtown whether it be in planters or some other way, but I'd like to focus on those types of plants that require the least amount of maintenance possible while still having a lovely aesthetic.
3. Pavers at intersections? I love the idea of pavers. Anything that creates a throwback feel to the downtown area is appealing to me. I have long imagined having the entire area from Jackson to Washington be pavers with arches welcoming you into downtown. Not sure those are the right spaces, but I think items like that are great. Downtown Plainfield is a place we have discussed quite a bit: <https://patch.com/illinois/plainfield/downtown-plainfield-listed-on-national-register-of-historic-places>
4. Define the area/scope. Obviously, the key piece for us first would be to get all the buildings out of the dilapidated appearance that they had when we first began this mission 3 years ago. We have made some progress, but there are still buildings that need considerable work (Palazollos and Dollar Store namely...also Rose Garden). We think code enforcement on those buildings is really the key to accelerating those locations to take advantage of the façade program. As far as scope goes, we want to do as much as possible. One of the things that Brad Sanderson once said was that you have to do streetscape like you do a building. You have to build from the foundation up. So, we would like to redo all the electrical under the sidewalks and make sure all utility upgrades are done, then we think lighting and speakers in the downtown would be next, then pavers and sidewalk style could follow, then items that call to Hampshire's history...maybe statues or monuments. As far as area, we have always wanted to believe that Main Street would one day stretch all the way out to Allen Road with a starting point at Jackson. We have also believed that one to two blocks either way to the East or West should also be considered our downtown.



# IMPROVEMENT PLANS FOR DOWNTOWN IMPROVEMENTS PHASE 1

VILLAGE OF HAMPSHIRE  
KANE COUNTY, ILLINOIS

JUNE 2003

**VILLAGE OF HAMPSHIRE OFFICIALS**

WILLIAM P. SCHMIDT	PRESIDENT
CHUCK ANDERSON	TRUSTEE
TOM BROWN	TRUSTEE
ED SZYDLOWSKI	TRUSTEE
ORRIS RUTH	TRUSTEE
WILLIAM SWALWELL	TRUSTEE
JAMES TAYLOR	TRUSTEE
LINDA R. VASQUEZ	VILLAGE CLERK
KATHRYN T. MICHAEL	TREASURER
MARK SCHUSTER	VILLAGE ATTORNEY
JOHN T. BINDER	SUPERINTENDENT OF PUBLIC WORKS

**INDEX OF SHEETS**

1. COVER SHEET
2. CONSTRUCTION SPECIFICATIONS AND SUMMARY OF QUANTITIES
3. ELECTRICAL SPECIFICATIONS
4. STATE STREET PLAN AND PROFILE STA. 33+50 TO STA 38+25
5. LIGHTING PLAN
6. ELECTRICAL DETAILS
7. PAVEMENT MARKING PLAN
8. LANDSCAPE PLAN
9. CROSS SECTIONS
10. TYPICAL DETAILS
11. TYPICAL DETAILS
12. TYPICAL DETAILS

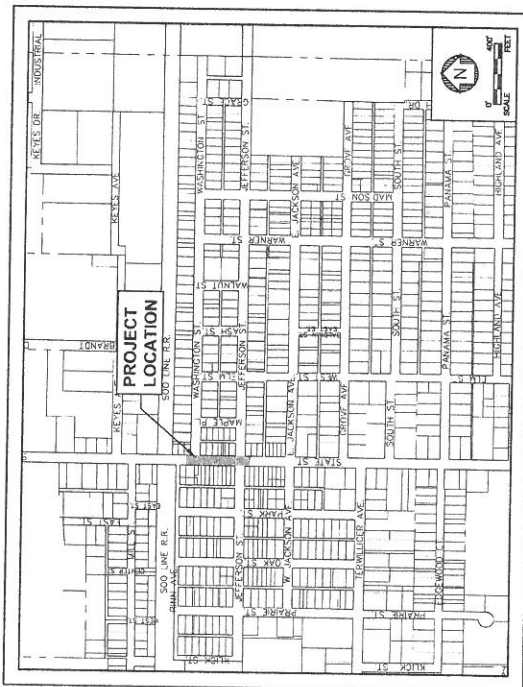

LOCATION MAP



**Engineering Enterprises, Inc.**  
Consulting Engineers  
52 Wheeler Road  
Sugar Grove, Illinois 60554  
630/468-9390

**BENCHMARKS**

1. TOP OF FIRE HYDRANT AT THE SOUTHEAST CORNER OF STATE AND JEFFERSON STREETS U.S.G.S. ELEVATION = 902.69
2. TOP OF FIRE HYDRANT AT THE SOUTHEAST CORNER OF STATE AND ELM STREETS U.S.G.S. ELEVATION = 897.73

**ENGINEER'S CERTIFICATION**

I HEREBY CERTIFY THAT THESE PLANS WERE PREPARED UNDER MY DIRECT SUPERVISION

DATED AT SUGAR GROVE, ILLINOIS,

THIS \_\_\_\_\_ DAY OF \_\_\_\_\_, 2003.

BRADLEY P. SANDERSON, P.E.  
REGISTERED PROFESSIONAL ENGINEER NO. 092-062821  
EXPIRATION DATE 11/29/03

NO.	DATE	REVISIONS	SHEETS





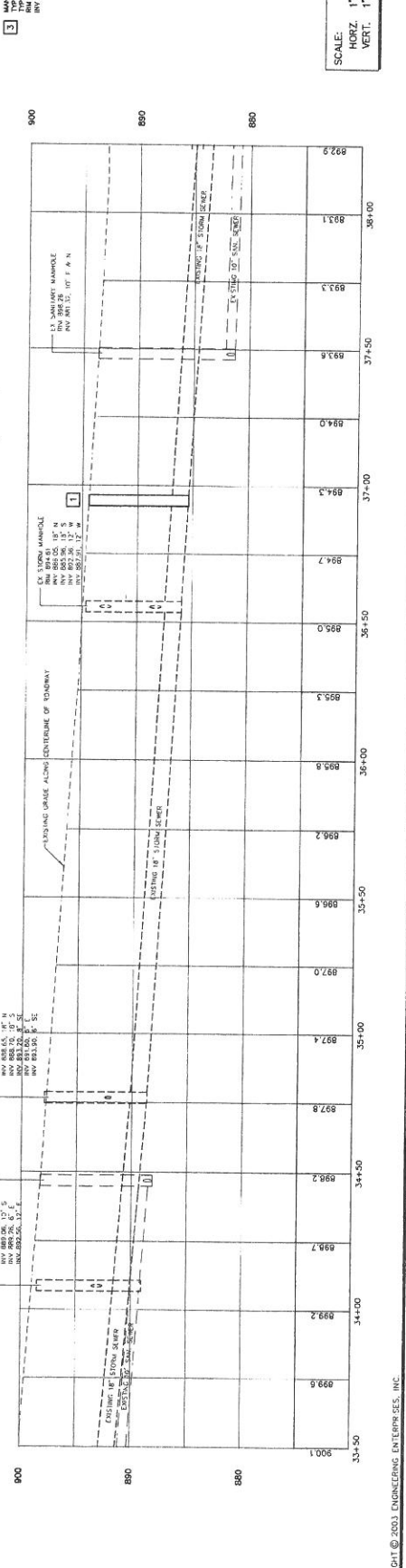
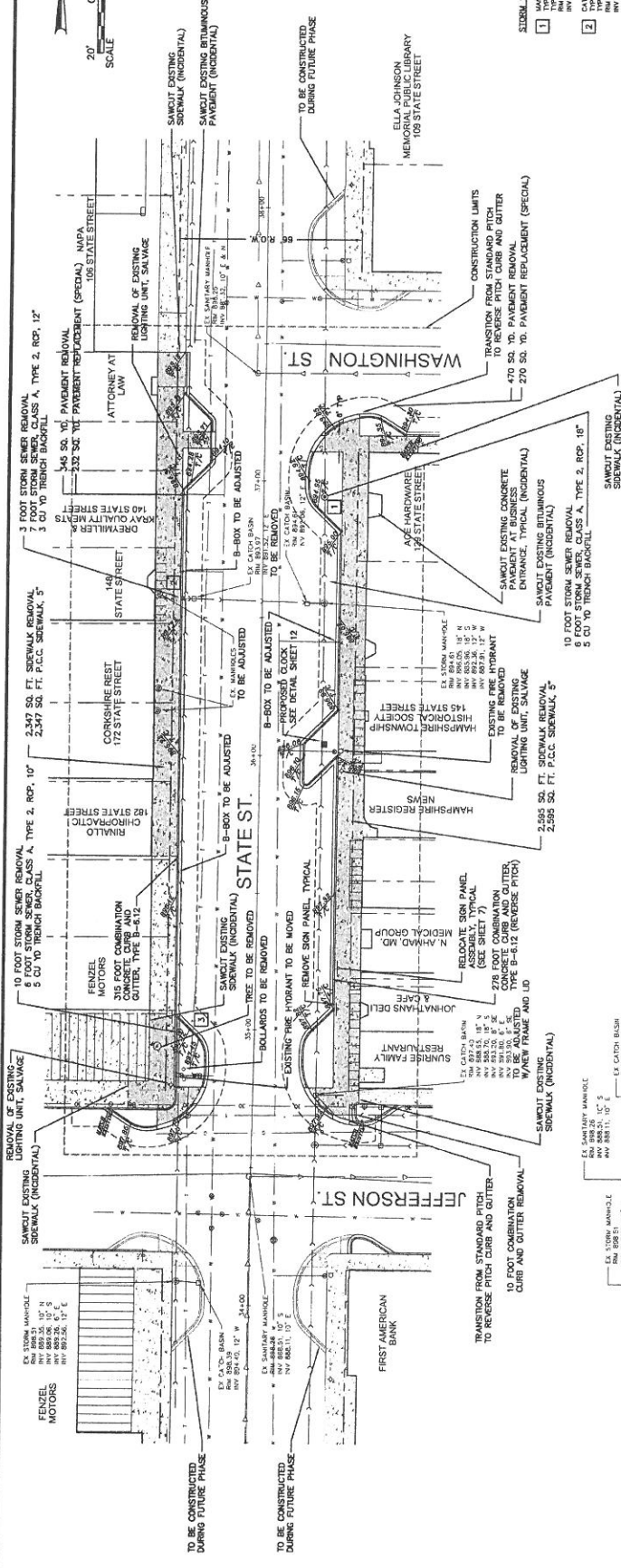
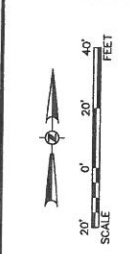

- STORM SEWER SCHEDULE**
- MANHOLE  
TYPE A, 4' DIA.  
INVERT 2.0' TO 4.0'  
INVERT 4.0' TO 6.0'  
INVERT 6.0' TO 8.0'  
INVERT 8.0' TO 10.0'
  - MANHOLE  
TYPE A, 4' DIA.  
INVERT 2.0' TO 4.0'  
INVERT 4.0' TO 6.0'  
INVERT 6.0' TO 8.0'  
INVERT 8.0' TO 10.0'
  - MANHOLE  
TYPE A, 4' DIA.  
INVERT 2.0' TO 4.0'  
INVERT 4.0' TO 6.0'  
INVERT 6.0' TO 8.0'  
INVERT 8.0' TO 10.0'

SCALE: 1" = 20'  
VERT. 1" = 5'

Engineering Enterprises, Inc.  
Consulting Engineers  
52 Wheeler Road  
Sugar Grove, Illinois 60554 630/466-8350

VILLAGE OF HAMPSHIRE  
KANE COUNTY, ILLINOIS

DOWNTOWN IMPROVEMENTS  
PHASE 1

STATE STREET  
PLAN AND PROFILE  
STA 33+50 TO STA 38+25

DATE: JUNE 2003  
PROJ. NO. HA0247  
FILE NO. HA024705

NO. DATE

REVISIONS

4 of 12

Copyright © 2003, ENGINEERING ENTERPRISES, INC.

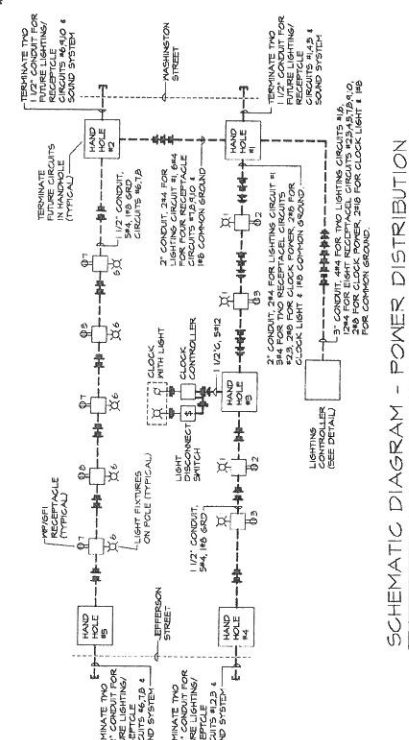
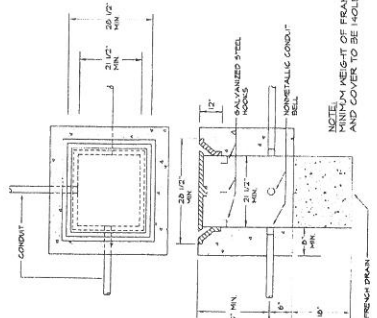
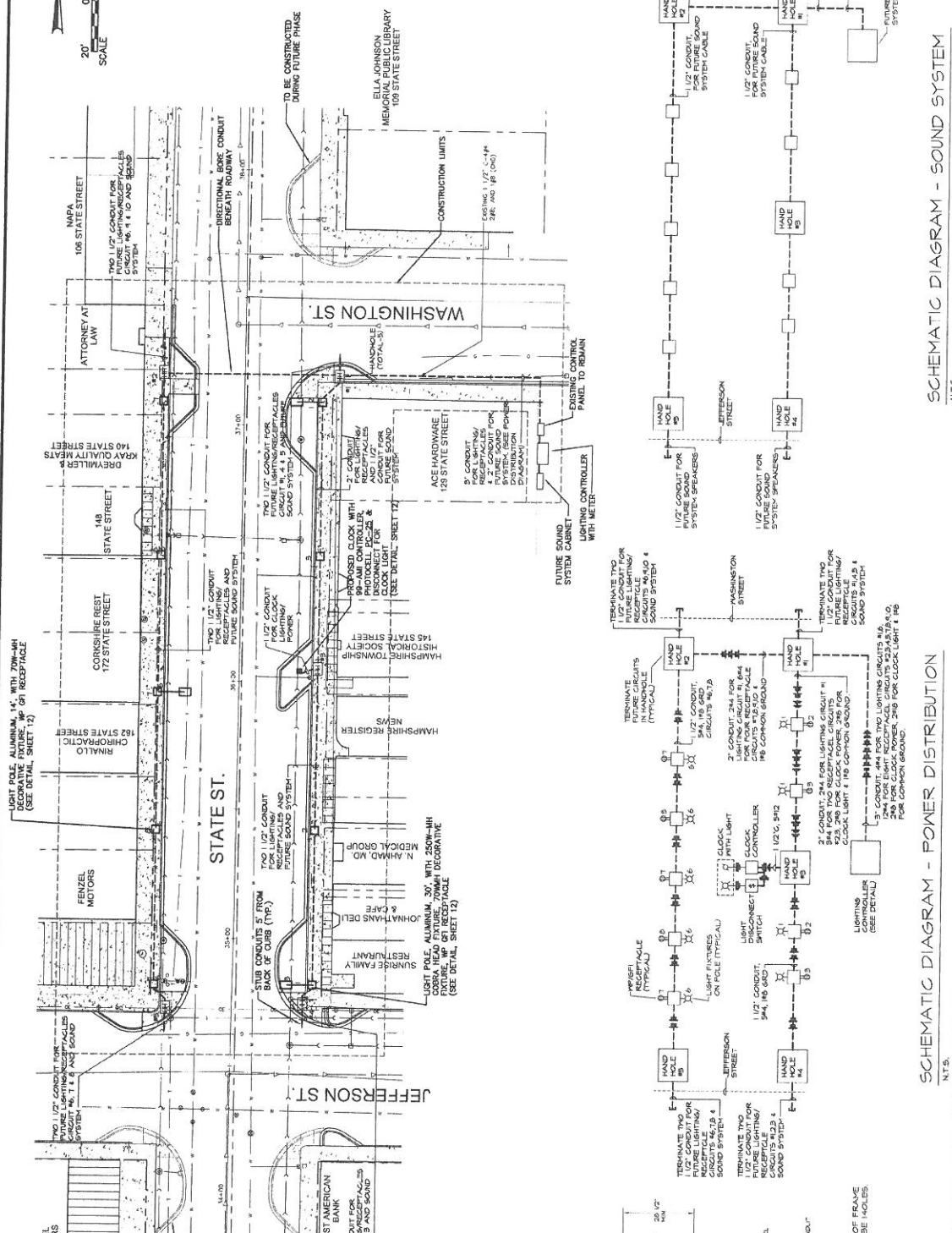
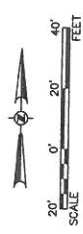

**SCHEMATIC DIAGRAM - POWER DISTRIBUTION**  
N.T.S.

**SCHEMATIC DIAGRAM - SOUND SYSTEM**  
N.T.S.

ENGINEERING ENTERPRISES, INC.  
 CONSULTING ENGINEERS  
 52 WHEELER ROAD  
 SUGAR GROVE, ILLINOIS 60554 630/466-9350

VILLAGE OF HAMPSHIRE  
 KANE COUNTY, ILLINOIS

DOWNTOWN IMPROVEMENTS  
 PHASE 1

LIGHTING PLAN

DATE: JUNE 2003  
 PROJ. NO.: HA0247  
 FILE NO.: HA024706  
 SHEET: 5 OF 12



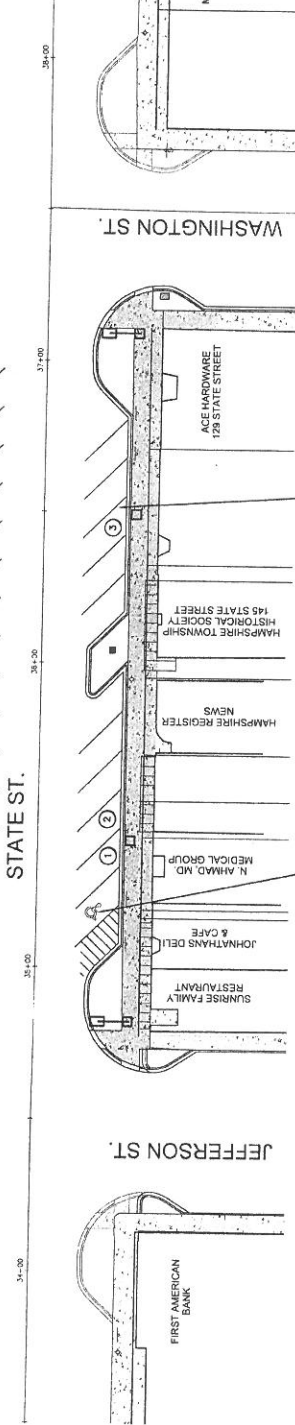
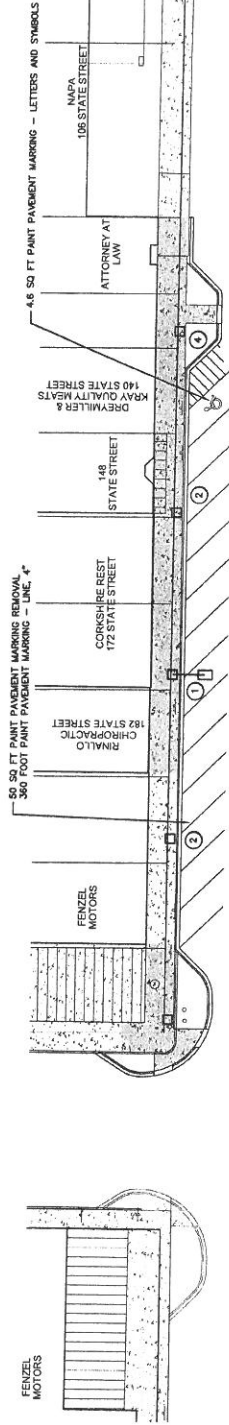
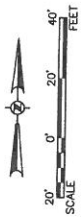

- SIGN PANEL SCHEDULE**
- ① NO PARKING, 1AM TO 6PM
  - ② THREE HOUR PARKING, 6AM TO 9PM, MON - SAT
  - ③ 30 MINUTE PARKING THIS SPACE ONLY
  - ④ ST. CHARLES BORROMEO CATHOLIC SCHOOL

NOTE: ALL SIGNS TO BE MOUNTED TO THE LEFT PANELS WITH THE EXCEPTION OF SCHOOL SIGNS WHICH ARE TO BE PROVIDED BY THE POLE MANUFACTURER.

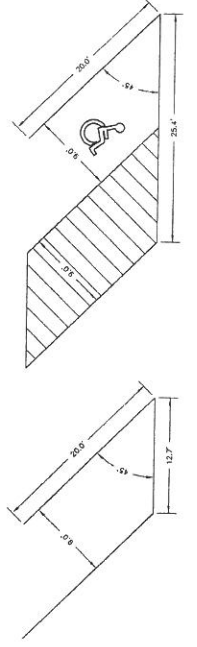

TYPICAL PARKING STALL DIMENSIONS  
NT.5.

Engineering Enterprises, Inc.  
Consulting Engineers  
52 Wheeler Road  
Sugar Grove, Illinois 60554 630/466-9350

VILLAGE OF HAMPSHIRE  
KANE COUNTY, ILLINOIS

DOWNTOWN IMPROVEMENTS  
PHASE 1

PAVEMENT MARKING PLAN

DATE: JUNE 2003  
PROJ. NO.: HA0247  
FILE NO.: HA024712

SHEET 7 OF 12

REVISIONS

NO.	DATE	REVISIONS

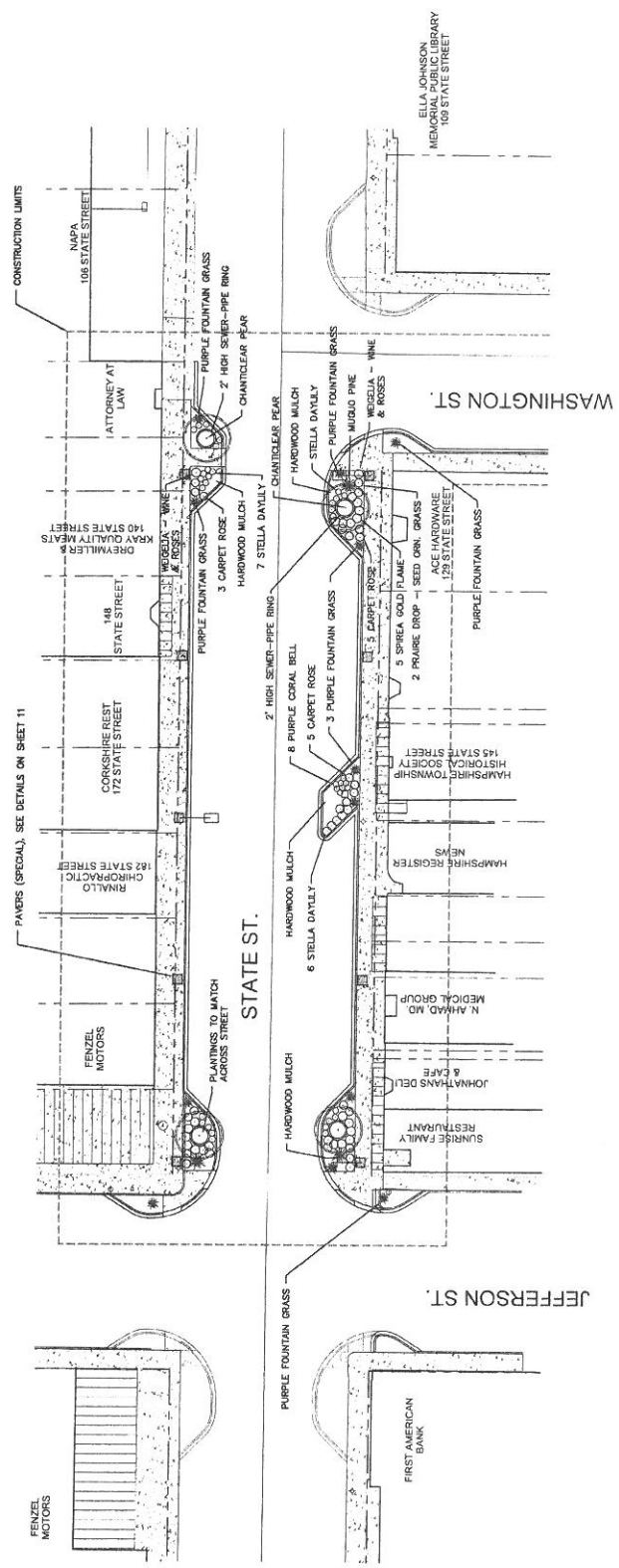
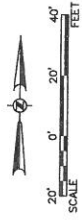

NOTE:  
 1. PAVER COLOR TO BE DETERMINED PRIOR TO INSTALLATION  
 2. PAVER PATTERN TO BE DETERMINED PRIOR TO INSTALLATION

Engineering Enterprises, Inc.  
 Consulting Engineers  
 52 Wheeler Road  
 Sugar Grove, Illinois 60554 630/466-9350

VILLAGE OF HAMPSHIRE  
 KANE COUNTY, ILLINOIS

LANDSCAPE PLAN  
 DOWNTOWN IMPROVEMENTS  
 PHASE 1

DATE: JUNE 2003  
 PROJ. NO.: HA0247  
 FILE NO.: HA02471

8 of 12 SHEET

NO. DATE REVISIONS

COPYRIGHT © 2003 ENGINEERING ENTERPRISES, INC.



SCALE: HORIZ. 1" = 10'  
VERT. 1" = 5'

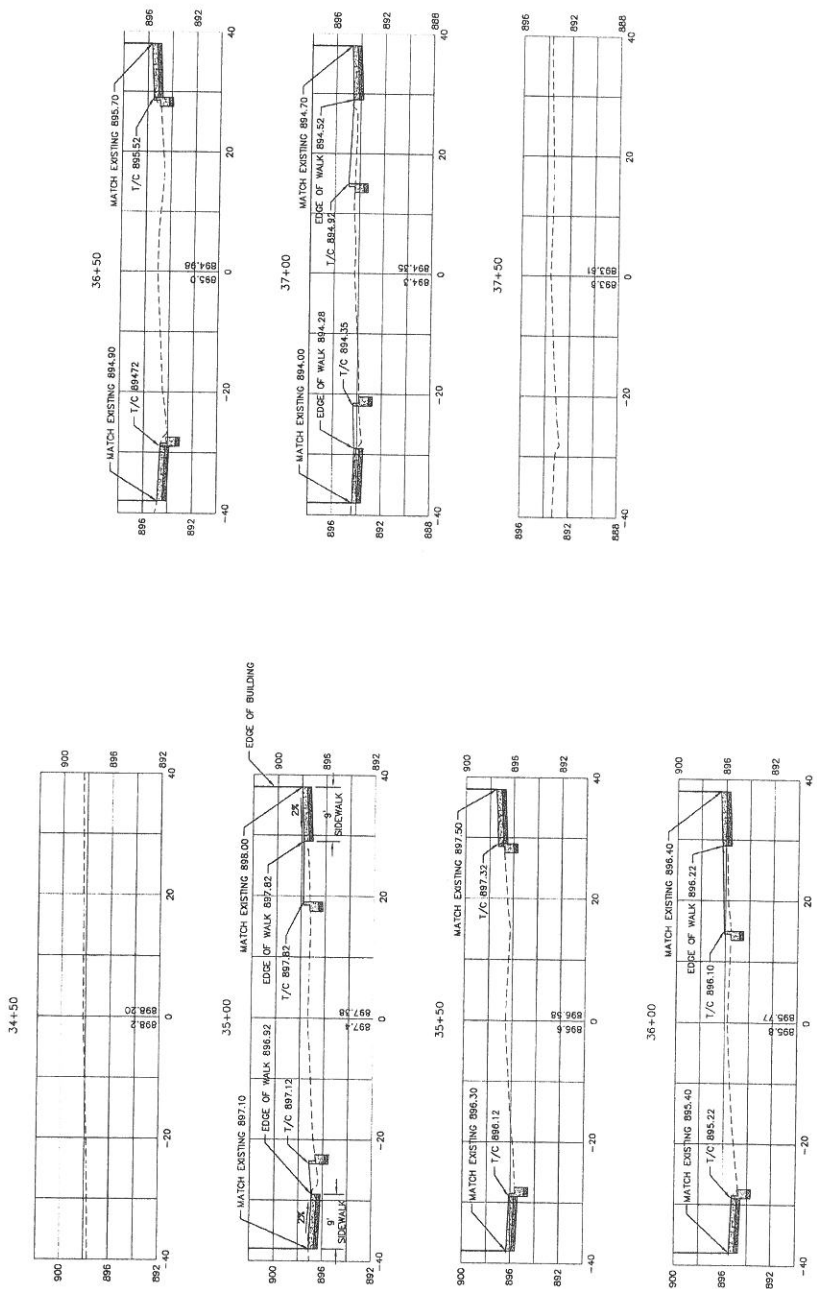

COPYRIGHT © 2003 ENGINEERING ENTERPRISES, INC.

Engineering Enterprises, Inc.  
Consulting Engineers  
52 Wheeler Road  
Sugar Grove, Illinois 60554 630/466-8350



VILLAGE OF HAMPSHIRE  
KANE COUNTY, ILLINOIS

NO.	DATE	REVISIONS

DOWNTOWN IMPROVEMENTS  
PHASE 1

CROSS SECTIONS

DATE: JUNE 2003  
PROJ. NO.: HA0247  
FILE NO.: HA024705  
SHEET: 9 of 12

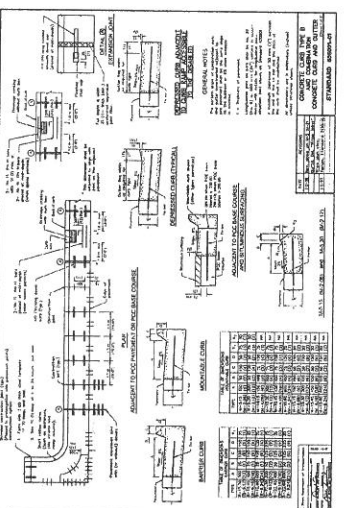
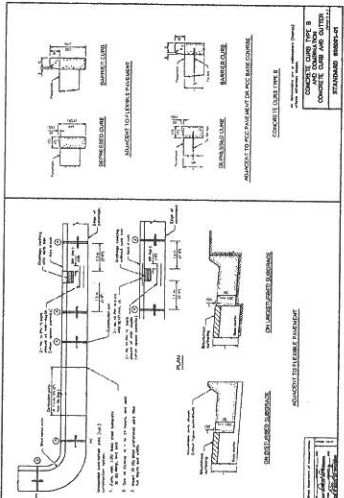
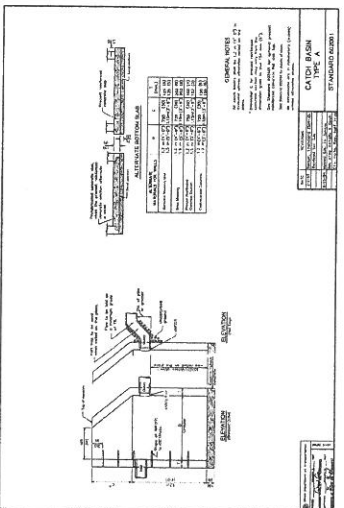
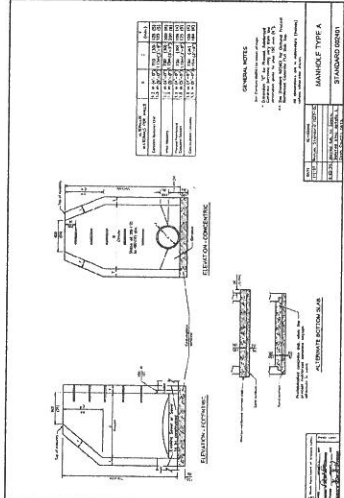
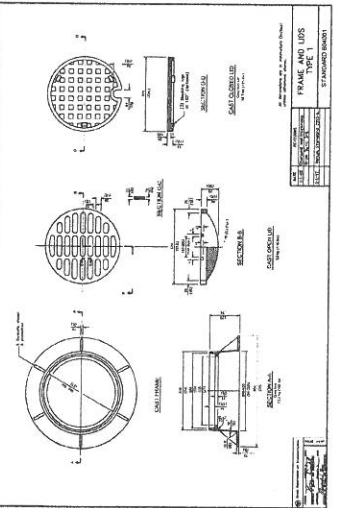
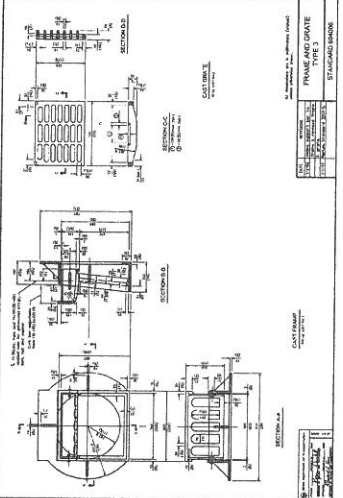
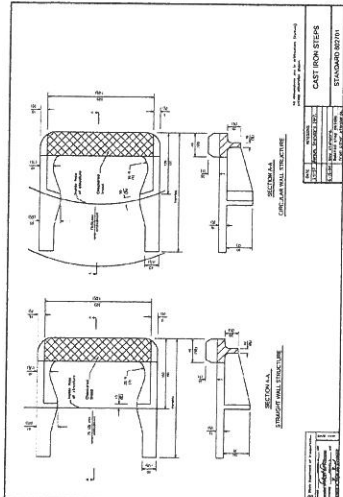

DATE: JUNE 2003  
PROJ. NO.: HA0247  
FILE NO.: HA024704  
SHEET: 10 of 12

TYPICAL DETAILS

DOWNTOWN IMPROVEMENTS  
PHASE 1

VILLAGE OF HAMPSHIRE  
KANE COUNTY, ILLINOIS

Engineering Enterprises, Inc.  
Consulting Engineers  
52 Wheeler Road  
Sugar Grove, Illinois 60554 630/466-9350



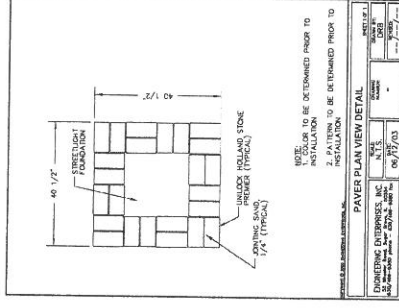
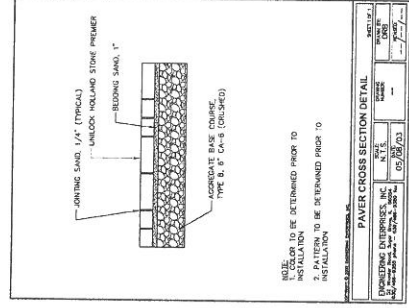
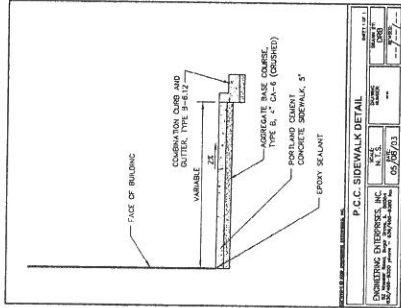
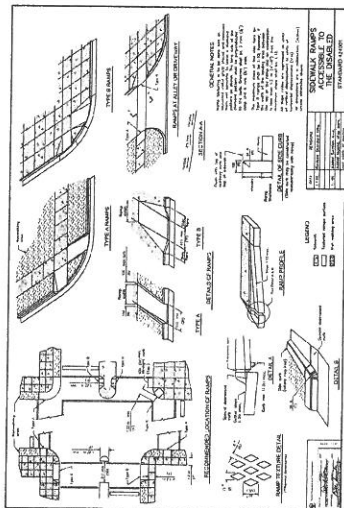
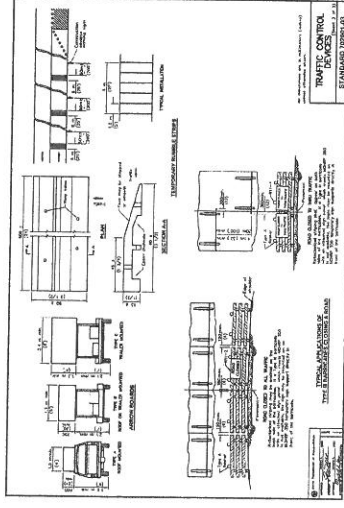
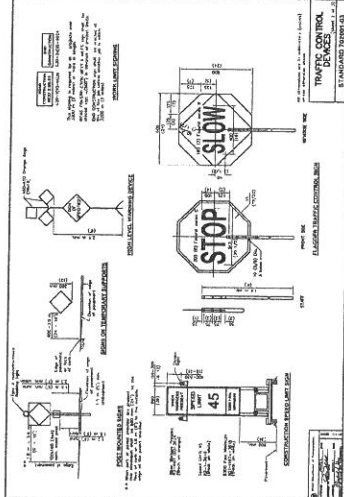
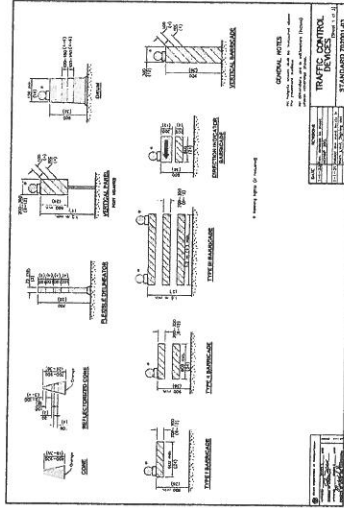

NO.	DATE	REVISIONS

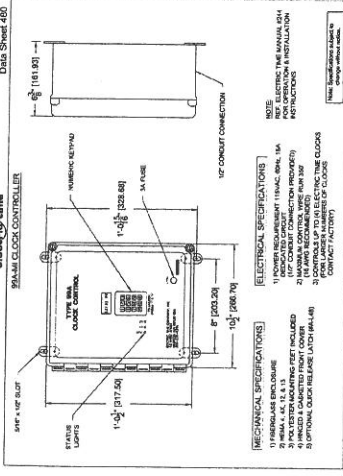

Electric Time Company, Inc. Modified, MA 02057 USA  
 http://www.electrotime.com

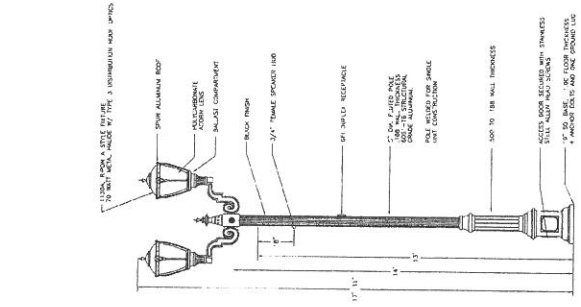
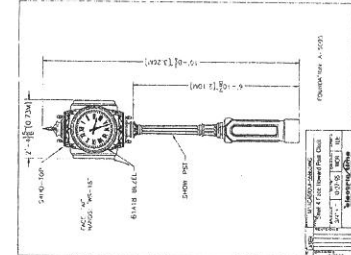
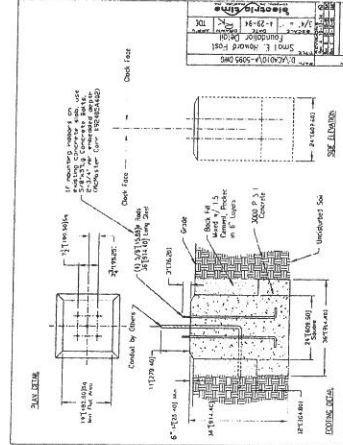
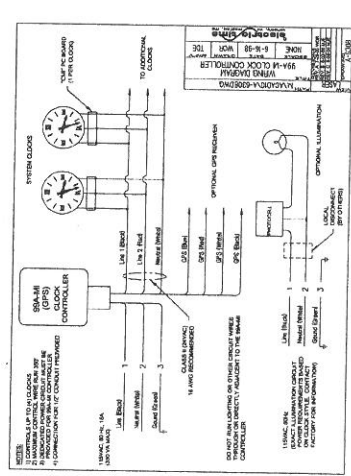

LIGHT POLE, ALUMINUM, 14'  
N.T.S.

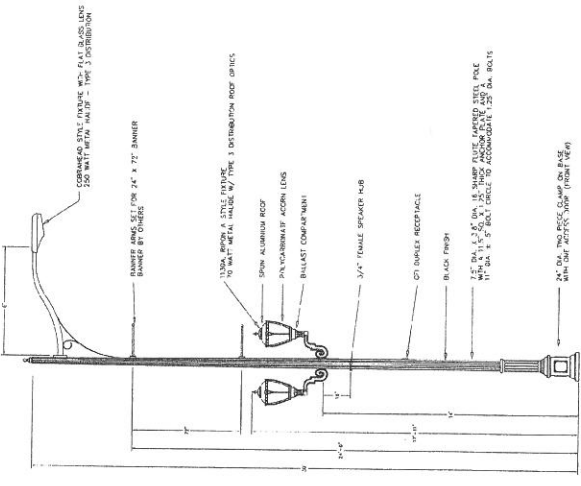

LIGHT POLE, ALUMINUM, 30'  
N.T.S.

## Streetscape Engineering Update from EEI

4/16/20

There are multiple Village utilities that are along State Street that require discussion. There were several separate projects undertaken by the Village during the 2000's that we were involved with. We had to go back and refresh our memories. I will try and summarize below:

### Stormwater/Drainage

- We have staff reviewing the televising info that Dave provided. The review should be complete by the end of the week.
- Please see the attached memo which summarized our findings from a 2008 investigation. This provides good background to some of the issues that were discovered.
- Lining of the main storm sewer line was completed in 2010. This effectively "cut-off" many of the connections that were noted in the memo referenced above. Generally, it is our understanding that this took care of many building related issues.
- The Village undertook another project in 2011, in which storm sewer/drainage improvements were made along Rinn as well as the Alley, west of State Street. This solved many issues also.
- The above noted work went a long way in alleviating the drainage issues. We are not certain if everything has been fully addressed as noted below.
- **Items to note:**
  - **We would recommend reconnecting with the businesses along State Street to obtain current information in regards to drainage issues.**
  - **The storm sewer along State Street that was lined is undersized for the tributary area. There have been several discussions over the years about upsizing and replacing.**

### Sanitary Sewer

- There has been various repairs/replacements performed on the sanitary sewer on State Street. Was this televised recently to confirm the integrity?

### Water Main/Water Services

- In 2007, water services were transferred from the old 4" water main to the newer (installed 1988) 12" water main. The old 4" water main was then abandoned. The area included Jefferson St. to Mill Ave.
- Sidewalk from Jefferson to Washington was also replaced in 2007.
- The Village completed the transfers from Jefferson St. to Jackson Street in 2009.
- We should be good to go with watermain/water services along State Street. **Note that we may need to address old 4" and 6" water main at the State Street intersections of Jefferson and Jackson.**

It would perhaps make sense to have a meeting/video conference to discuss the above and to also get a better understanding of the following:

- What are the current goals of the project?
- What will be the nature of the improvements?
- What is the budget of the project?

- What issues are present from Public Works perspective?
  - Water
  - Sanitary
  - Storm/Drainage
- What issues are present from property owner perspective?
  - Storm/Drainage

Thanks and let us know if you have any questions.