



Village of Hampshire  
Village Board Meeting  
Thursday, November 21, 2024 - 7:00 PM  
Hampshire Village Hall  
234 South State Street, Hampshire, IL 60140

## AGENDA

1. Call to Order
2. Roll Call
3. Pledge of Allegiance
4. Public Comments
5. A Motion to Approve the Meeting Minutes from November 7, 2024
6. Appointments
  - a. Motion to Approve Appointment of Mary Brandes as Deputy Village Clerk
  - b. Motion to Approve Appointment of Mo Khan as Deputy Village Clerk
7. Village Manager's Report
  - a. Motion to Award a Façade Improvement Grant to Neon Cow at 145 S. State St. in the Amount to Not Exceed \$19,965 (75% of Total Project Cost)
  - b. Discussion on a Façade Improvement Grant Award for The Kave at 123 Washington in the Amount to Not Exceed \$17,925 (50% of Total Project Cost) to be Awarded in Fiscal Year 2026
  - c. Resolution Determining the Amount of Funds to be Levied and Setting the Public Hearing for Corporate Tax Levy
  - d. Resolution Authorizing Expenditure for Purchase of a Cab & Chassis for a Snowplow Truck in the Amount of \$122,747
  - e. Resolution Authorizing the Sale of a 2018 Ford Explorer to the Hampshire Fire Protection District in the amount of \$10,500
  - f. Resolution Accepting the Public Improvements to Ryan Drive and Releasing Bonds for Ryan Drive and Old Dominion Development at 200 Ryan Drive
  - g. Presentation on Special Service Area Tax Levies
8. Staff Reports
  - a. Police Report
  - b. Streets Report
  - c. Financial Report
9. Accounts Payable
  - a. A Motion to Approve the November 21, 2024, Accounts Payable to Personnel
  - b. A Motion to Approve the November 21, 2024, Regular Accounts Payable

10. Village Board Committee Reports
  - a. Business Development Commission
11. New Business
12. Announcements
13. Executive Session
  - a. Review of Executive Session Minutes
  - b. Discussion of Personnel Matters
14. Adjournment

Public Comments: The Board will allow each person who is properly registered to speak a maximum time of five (5) minutes, provided the Village President may reduce the maximum time to three (3) minutes before public comments begin if more than five (5) persons have registered to speak. Public comment is meant to allow for expression of opinion on, or for inquiry regarding, public affairs but is not meant for debate with the Board or its members. Good order and proper decorum shall always be maintained.

Recording: Please note that all meetings held by videoconference may be recorded, and all recordings will be made public. While State Law does not require consent, by requesting an invitation, joining the meeting by link or streaming, all participants acknowledge and consent to their image and voice being recorded and made available for public viewing.

Accommodations: The Village of Hampshire, in compliance with the Americans with Disabilities Act, requests that persons with disabilities, who require certain accommodations to allow them to observe and/or participate in the meeting(s) or have questions about the accessibility of the meeting(s) or facilities, contact the Village at 847-683-2181 to allow the Village to make reasonable accommodations for these persons.



Village of Hampshire  
Village Board Meeting Minutes  
Thursday, November 7, 2024 - 7:00 PM  
Hampshire Village Hall  
234 South State Street, Hampshire, IL 60140

**1. Call to Order**

Village President Michael J. Reid Jr. called to order the Village Board Meeting at 7:00 p.m. in the Village of Hampshire Village Board Room, 234 S. State Street, on Thursday, November 7, 2024.

**2. Roll Call by Village Clerk, Karen Stuehler:**

Present: Village President Michael J. Reid Jr., Trustee Fodor, Trustee Kelly, Trustee Koth, Trustee Lionel Mott, Trustee Pollastrini, Trustee Robinson.

Absent: None.

A Quorum was Established.

Others Present: Village Manager Jay Hedges, Village Clerk Karen Stuehler, Chief Pann, Assistant Village Manager for Development Mo Khan, Village Attorney James Vasselli. Finance Director Lori Lyons and Tim Paulson from EEI joined remotely.

**3. Pledge of Allegiance**

President Michael J. Reid Jr. led the Pledge of Allegiance.

**4. Public Comments**

None

**5. A Motion to Approve the Meeting Minutes from October 17, 2024.**

Trustee Pollastrini moved to approve the Meeting Minutes from October 17, 2024.

Seconded by: Trustee Mott.

Roll Call Vote:

Ayes: Fodor, Kelly Koth, Mott, Pollastrini, Robinson.

Nays: None.

Absent: None.

Abstain: None.

Motion Approved.

6. **Proclamation**

President Michael J. Reid Jr. made a Proclamation for the month of November to be Children’s Grief Awareness Month.

7. **A motion to Approve the Appointment of Christine Klein as chairperson of the Planning & Zoning Commission for a Term through May 2026.**

- a. Trustee Koth moved to Approve the Appointment of Christine Klein as chairperson of the Planning & Zoning Commission for a Term through May 2026.

Seconded by: Trustee Fodor.

Roll Call Vote:

Ayes: Fodor, Kelly Koth, Mott, Pollastrini, Robinson.

Nayes: None.

Absent: None.

Abstain: None.

Motion Approved.

- b. **A motion to Approve the Appointment of Ronald Ross as chairperson of the Planning & Zoning Commission for a Term through May 2028.**

Trustee Koth moved to Approve the Appointment of Ronald Ross as chairperson of the Planning & Zoning Commission for a Term through May 2028.

Seconded by: Trustee Fodor.

Roll Call Vote:

Ayes: Fodor, Kelly Koth, Mott, Pollastrini, Robinson.

Nayes: None.

Absent: None.

Abstain: None.

Motion Approved.

8. **Village Manager’s Report**

- a. **A Motion to Approve Ordinance 24-40 a Variance for 200 Red Hawk Dr. to permit a Shed in an Easement.**

Trustee Koth moved to approve Ordinance 24-40 a Variance for 200 Red Hawk Dr. to permit a Shed in an Easement.

Seconded by: Trustee Fodor.

Roll Call Vote:

Ayes: Fodor, Kelly, Koth, Mott, Pollastrini, Robinson

Nayes: None.

Absent: None.

Abstain: None.

Motion Approved.

b. Sharon Durling gave a presentation Regarding Renewal of Aggregation Program for electrical Load.

c. **A Motion to Approve Ordinance 24-41 Approving an Extension to an Intergovernmental Agreement with the City of Elgin regarding a Boundary Line Agreement.**

Trustee Robinson moved to approve an Ordinance 24-41 Approving an Extension to an Intergovernmental Agreement with the City of Elgin regarding a Boundary Line Agreement.

Seconded by: Trustee Koth.

Roll Call Vote:

Ayes: Fodor, Kelly, Koth, Mott, Pollastrini, Robinson.

Nayes: None.

Absent: None.

Abstain: None.

Motion Approved.

d. **A Motion to Approve Resolution 24-39 Approving a Contract with American Pipeline Solutions for Well 13 Raw Watermain Cleaning in the Amount of \$88,862.**

Trustee Mott moved to approve Resolution 24-39 Approving a Contract with American Pipeline Solutions for Well 13 Raw Watermain Cleaning in the Amount of \$88,862.

Seconded by: Trustee Fodor.

Roll Call Vote:

Ayes: Fodor, Kelly, Koth, Mott, Pollastrini, Robinson.

Nayes: None.

Absent: None.

Abstain: None.

Motion Approved.

- e. **A Motion to Approve Resolution 24-40 Waiving Formal Bidding and Approving a Contract with Trojan Technologies for Wastewater Treatment Facility Ultraviolet (UV) Syster Equipment in the Amount of \$292,308.**

Trustee Robinson moved to Approve Resolution 24-40 Waiving Formal Bidding and Approving a Contract with Trojan Technologies for Wastewater Treatment Facility Ultraviolet (UV) Syster Equipment in the Amount of \$292,308.

Seconded by: Trustee Koth.

Roll Call Vote:

Ayes: Fodor, Kelly, Koth, Mott, Pollastrini, Robinson.

Nayes: None.

Absent: None.

Abstain: None.

Motion Approved.

- f. **A Motion to Approve Resolution 24-41 Waiving Formal Bidding and Approving a Contract with Vafcon for Wastewater Treatment Plan Variable Frequency Drives (VFDs) in the Amount of \$160,000.**

Trustee Robinson moved to approve Resolution 24-41 Waiving Formal Bidding and Approving a Contract with Vafcon for Wastewater Treatment Plan Variable Frequency Drives (VFDs) in the Amount of \$160,000.

Seconded by: Trustee Koth.

Roll Call Vote:

Ayes: Fodor, Kelly, Koth, Mott, Pollastrini, Robinson.

Nayes: None.

Absent: None.

Abstain: None.

Motion Approved.

## 9. **Staff Reports**

- a. Building Report:

No Discussion

- b. Engineering Report:

Discussion was had about Safe route to School.

Trustee Pollastrini asked about the Park and Rinn Project and it was reported that it has been approved and waiting for engineering.

#### 10. **Accounts Payable**

- a. A Motion to Approve November 7, 2024 Account Payable to Personnel in the amount of \$304.99.

Trustee Kelly moved to Approve November 7, 2024 Account Payable to Personnel in the amount of \$304.99.

Seconded by: Trustee Pollastrini.

Roll Call Vote.

Ayes: Fodor, Kelly, Koth, Mott, Pollastrini, Robinson.

Nayes: None.

Absent: None.

Abstain: None.

Motion Approved.

- b. A Motion to Approve November 7, 2024, Regular Accounts Payable in the amount of \$383,551.16.

Trustee Koth moved to Approve November 7, 2024, Regular Accounts Payable in the amount of \$383,551.16

Seconded by: Trustee Mott.

Roll Call Vote.

Ayes: Fodor, Kelly, Koth, Mott, Pollastrini, Robinson.

Nayes: None.

Absent: None.

Motion Approved.

#### 11. **Village Board Committee Reports**

- a. Business Development Commission

Trustee Kelly reported that there is a meeting on Wednesday, November 13, 2024 at 6:30 p.m.

#### **New Business**

Discussion was had in regards to Canadian Railway fixing the crossing on State Street.

## 12. **Announcements**

Trustee Kelly wanted to thank Village Attorney, Jim Vasselli and the Board for helping him to understand and for their patience.

Attorney Vasselli thinks that Trustee Kelly is great.

Trustee Robinson would like to Thank all the Veterans for their service.

President Reid informed everyone that there would be a parade and dinner on Monday Night to honor the Veterans. This is being sponsored by Ane Jashari and the Hampshire Township.

Trustee Kelly also said that Copper Barrel is giving dinner to all Veterans.

President Reid Shared that the Pumpkin Smash at Henpeck Park on Saturday ran by Meg Dongarra.

Village Manager Jay Hedges also shared that Flood Brothers would be donating a scale for the Pumpkin smash event.

Trustee Pollastrini and Trustee Mott reminded everyone of the Lions club Meat Raffle on Friday, November 8 at 4:30. Locations will be Copper Barrel, Harps Lounge, Newman's and The Kave. Proceeds will benefit two families.

Trustee Kelly informed everyone that Garden Berry was changing owners, and the New Restaurant would be Angels Pancakes.

## 13. **Executive Session**

No discussion.

## 14. **Adjournment**

Trustee Koth moved to adjourn at 8:52 p.m.

Seconded by: Trustee Mott.

All Call Vote.

Ayes: Fodor, Kelly, Koth, Mott, Pollastrini, Robinson.

Nays: None.

Absent: None.

Motion Approved.





Village of Hampshire  
 234 S. State Street, Hampshire IL 60140  
 Phone: 847-683-2181      www.hampshireil.org

## Agenda Supplement

**TO: President Reid; Board of Trustees**  
**FROM: Mo Khan, Assistant Village Manager for Development**  
**FOR: Village Board Meeting on November 21, 2024**  
**RE: FY2025 Façade Improvement Grant Applications - Consideration & Award**

**Background:** The Village offers a Façade Improvement Grant program for businesses in the Downtown area that seek to renovate and refresh the building’s street facing façade. For Fiscal Year 2025, \$50,000 in potential grants was budgeted. Previously in September 2024, the Village Board awarded three grants totaling \$24,287.85. The remaining amount in the program budget is \$25,712.15.

**Analysis:** At the November 13, 2024 Business Development Commission meeting, the BDC considered a grant application for the property located at 145 S. State St., which is where the Neon Cow is located. The BDC recommended awarding the grant at a 75% reimbursement level. Details of the three previous grants awarded and the recommendation for the Neon Cow are provided in the table below:

<b>Business</b>	<b>Address</b>	<b>Project Description</b>	<b>Project Amount</b>	<b>75% Award Amount</b>
Delta Yoga	184 S. State	Projecting Sign	\$1,493.80	\$1,120.35 <sup>#</sup>
State Farm	185 S. State	Awning & Sign	\$3,590	\$2,692.50 <sup>#</sup>
Style on State	165 S. State	Façade Renovation	\$23,000	\$20,475 <sup>#</sup>
Neon Cow	145 S. State	Front Façade & Awning	\$26,620	\$19,965
			<b>Total:</b>	<b>\$44,252.85</b>
			<b>Remaining:</b>	<b>\$5,747.15</b>

<sup>#</sup> Previously approved and awarded grants

**Recommendation:** For the Village Board to consider and award a Façade Improvement Grant for 145 S. State St.

**Documents Attached:**

1. Neon Cow Façade Grant Application



Village of Hampshire  
234 S. State Street, Hampshire, IL 60140  
Phone: 847-683-2181 • www.hampshireil.org

## FAÇADE IMPROVEMENT PROGRAM APPLICATION

### Applicant Information:

Name: DON LOVERDE Phone: 847-812-8121  
Address: 783 PROVIDENCE Email: LOVERDECONTRACTING@GMAIL.COM  
CRYSTAL LAKE

### Property Owner Information (if different from applicant):

Name: (SAME) Phone: \_\_\_\_\_  
Address: \_\_\_\_\_ Email: \_\_\_\_\_

### Property Information

Business Name: NEON COW Total Eligible Expenses: \_\_\_\_\_  
Address: 145 S. STATE ST. Parcel Identification Number: D1-22-352-003

### Proposed Improvements (Check all that apply):

- |   |   |
|---|---|
| <input type="checkbox"/> Brick Cleaning                               | <input type="checkbox"/> Original architectural features repair and replacement |
| <input type="checkbox"/> Awnings                                      | <input type="checkbox"/> Exterior doors   |
| <input checked="" type="checkbox"/> Tuck Pointing                     | <input type="checkbox"/> Windows and window frames                              |
| <input checked="" type="checkbox"/> Exterior Lighting                 | <input checked="" type="checkbox"/> Shutters                                    |
| <input checked="" type="checkbox"/> Painting                          | <input type="checkbox"/> Stairs, porches, railings                              |
| <input type="checkbox"/> Streetscape elements                         | <input type="checkbox"/> Roof   |
| <input checked="" type="checkbox"/> Wall facade repair or improvement | <input type="checkbox"/> Exterior improvements for ADA                          |
| <input type="checkbox"/> Landscaping                                  |   |
| <input type="checkbox"/> Other  |   |

### Description of proposed work:

1. REMOVE OVERHANG, AND REBUILD. (SHAKES AND PLYWOOD, WHERE NEEDED)
2. INSTALL RAISED SEAM METAL SHEETS, AND SOFFIT & FASCIA
3. REMOVE SHUTTERS & 2 NIGHT FIXTURES
4. INSTALL NEW NIGHTS ON WALL, AND IN OVERHANG
5. TUCKPOINT WALL WHERE NEEDED.
6. PAINT WINDOWS AND DOOR FRAMES.

I agree to comply with the guidelines and standards of the Village of Hampshire facade Improvement Assistance Program and I understand that this is a voluntary program under which the village has the right to approve or deny any project or proposal or portions thereof.



Applicant Signature

Date

Don P. Novak  
Print Name

If the applicant is other than the owner, the owner must complete the following:

I certify that I am the owner of the property located at 145 S. STATE ST., Hampshire, IL, and that I authorize the applicant to apply for assistance under the Village of Hampshire Facade Improvement Program and undertake the approved improvements.

\_\_\_\_\_

Signatures

Date

\_\_\_\_\_

Print Names



**LO VERDE CONTRACTING CO.**

**QUOTE**

20746 LONG GROVE RD.  
 KILDEER, IL. 60047  
 CELL: 847-812-2121  
 EMAIL: loverdecontracting@gmail.com

**Date: 11/6/2024**

**BILL TO:**

145 STATE ST.  
 HAMPSHIRE, IL

<b>OUR #</b>	<b>TERMS</b>
145STATEFACADE	

DESCRIPTION	TOTAL
1. REMOVE CEDAR SHAKES FROM UPPER & LOWER CANAOPIES & DISPOSE OF DEBRIS IN DUMPSTER	\$ 2,500.00
2. INSPECT PLYWOOD & REPLACE WHERE NEEDED	\$ 2,000.00
3. PROVIDE & INSTALL ICE & WATER SHIELD ON ENTIRE AREA	\$ 1,500.00
4. PROVIDE & INSTALL METAL ROOFING MATERIAL & TRIMS (AS PER SAMPLE)	\$ 13,620.00
5. PROVIDE & INSTALL ALUMINUM SOFFIT & FASCIA (WHITE)	\$ 2,500.00
6. REMOVE 2 COACH LIGHTS ON EITHER SIDE OF SIGN, & CAP	\$ 300.00
7. REMOVE SHUTTERS & PATCH HOLES	\$ 250.00
8. TUCKPOINT WHERE NEEDED	\$ 250.00
9. PREP & PAINT WINDOW FRAMES & DOOR FRAME (BLACK)	\$ 900.00
10. CORE CONCRETE, & PROVIDE & INSTALL POSTS & GATE IN FRONT, BETWEEN BUILDINGS	\$ 1,800.00
11. DUMPSTERS & PERMIS	\$ 1,000.00
<b>MATERIAL &amp; LABOR</b>	<b>\$ 26,620.00</b>

**NOTE: BARRICADING OF SIDEWALK & AN OVERSEER FOR SAFETY INCLUDED**

**BAL DUE**

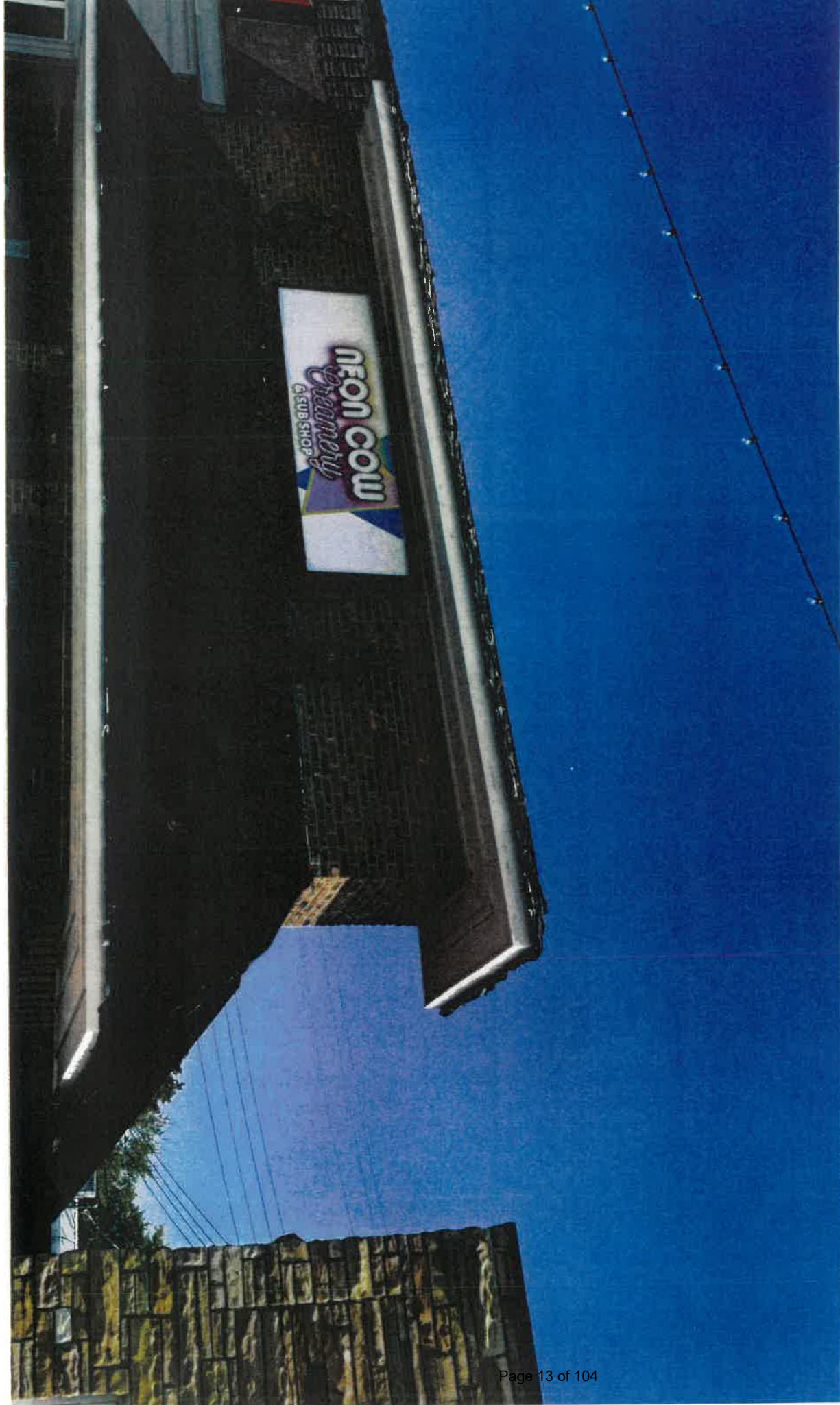



Village of Hampshire  
 234 S. State Street, Hampshire IL 60140  
 Phone: 847-683-2181      www.hampshireil.org

## Agenda Supplement

**TO: President Reid; Board of Trustees**  
**FROM: Mo Khan, Assistant Village Manager for Development**  
**FOR: Village Board Meeting on November 21, 2024**  
**RE: FY2025 Façade Improvement Grant Applications - Consideration & to Award in Fiscal Year 2026**

**Background:** The Village offers a Façade Improvement Grant program for businesses in the Downtown area that seek to renovate and refresh the building’s street facing façade. For Fiscal Year 2025, \$50,000 in potential grants was budgeted. Previously in September 2024, the Village Board awarded three grants totaling \$24,287.85. The remaining amount in the program budget is \$5,747.15, pending the award of a façade grant to the Neon Cow.

**Analysis:** At the November 13, 2024 Business Development Commission meeting, the BDC considered a grant application for The Kave, located at 123 Washington Ave. The BDC recommended awarding the grant at a 50% reimbursement level, which would \$17,925. However, since there is not enough in the budget to fund the project at a 50% reimbursement level, the BDC recommended that the item be brought forth to the Village Board as a discussion item to consider awarding the grant as part of the Fiscal Year 2026 Façade Improvement Grant program, if the program is funded in the next budget.

Details of the three previous grants awarded and the recommendation for the Neon Cow are provided in the table below:

<b>Business</b>	<b>Address</b>	<b>Project Description</b>	<b>Project Amount</b>	<b>75% Award Amount</b>
Delta Yoga	184 S. State	Projecting Sign	\$1,493.80	\$1,120.35 <sup>#</sup>
State Farm	185 S. State	Awning & Sign	\$3,590	\$2,692.50 <sup>#</sup>
Style on State	165 S. State	Façade Renovation	\$23,000	\$20,475 <sup>#</sup>
Neon Cow	145 S. State	Front Façade & Awning	\$26,620	\$19,965
			<b>Total:</b>	<b>\$44,252.85</b>
			<b>Remaining:</b>	<b>\$5,747.15</b>

<sup>#</sup> Previously approved and awarded grants

**Recommendation:** For the Village Board to discuss awarding a façade improvement grant to the Kave as part of the Fiscal Year 2026 program.

**Documents Attached:**

1. The Kave Façade Grant Application



Village of Hampshire  
234 S. State Street, Hampshire, IL 60140  
Phone: 847-683-2181 ▪ www.hampshireil.org

## FAÇADE IMPROVEMENT PROGRAM APPLICATION

### Applicant Information:

Name: GINA PEARSON Phone: 847-346-8165  
Address: 16N 971 GLEN OAKS CT. Email: ginapearson.73@gmail.com  
HAMPSHIRE, IL 60140

### Property Owner Information (if different from applicant):

Name: ORRIS RUTH Phone: 224-828-1209  
Address: 152 SOUTH AV Email: N/A.  
HAMPSHIRE, IL 60140

### Property Information

Business Name: THE KAVE Total Eligible  
Expenses: \_\_\_\_\_  
Address: 123 WASHINGTON AVE Parcel Identification  
Number: 01-22-352-008

### Proposed Improvements (Check all that apply):

- |  |   |
|--|---|
| <input type="checkbox"/> Brick Cleaning                    | <input checked="" type="checkbox"/> <u>Original architectural features repair and replacement</u> |
| <input type="checkbox"/> Awnings                           | <input checked="" type="checkbox"/> Exterior doors  |
| <input checked="" type="checkbox"/> Tuck Pointing          | <input checked="" type="checkbox"/> Windows and window frames                                     |
| <input type="checkbox"/> Exterior Lighting                 | <input type="checkbox"/> Shutters   |
| <input type="checkbox"/> Painting                          | <input type="checkbox"/> Stairs, porches, railings  |
| <input type="checkbox"/> Streetscape elements              | <input type="checkbox"/> Roof   |
| <input type="checkbox"/> Wall facade repair or improvement | <input type="checkbox"/> Exterior improvements for ADA  |
| <input type="checkbox"/> Landscaping                       | <input type="checkbox"/> Other: _____   |



**Description of proposed work:**

REMOVE & REPLACE 9 OR 18 WINDOWS, REMOVE & REPLACE  
1- EXTERIOR DOOR. REFRAME WINDOWS AS NEEDED.  
TUCKPOINT & BRICK REPAIR AS NEEDED, WRAP EXTERIOR  
WINDOWS IN BUTTE ALUMINUM.

**Acknowledgement:**

I agree to comply with the guidelines and standards of the Village of Hampshire facade Improvement Assistance Program and I understand that this is a voluntary program under which the village has the right to approve or deny any project or proposal or portions thereof.

  
Applicant Signature

10-29-24  
Date

GINA K. PEARSON  
Print Name

If the applicant is other than the owner, the owner must complete the following:

I certify that I am the owner of the property located at 123 WASHINGTON AVE  
Hampshire, IL, and that I authorize the applicant to apply for assistance under the Village of  
Hampshire Facade Improvement Program and undertake the approved improvements.

  
Signature

10-29-24  
Date

ORRIS C. RUTH.  
Print Name

**Facade Improvement Program Committee,**

**The KAVE and The Ruth family are preparing to celebrate 89 years of serving Hampshire! That is a lot of Old Style! As we celebrate, we also are continuing to look at the ongoing list of repairs needed on one of Hampshire's oldest downtown buildings. We are so thankful for our previous awarded grants from this committee, we continue to get compliments on the visual improvements of the building. We truly could not have done those past improvements without the Grant program!**

**Enclosed you will find 2 bids from 2 different contractors. One for 9 windows and a door and 18 windows and a door. The other bid is for 18 windows and a door. Our choice for the contractor to perform the job would be MLE Enterprises, he was also the contractor to perform some of the previous Grant work on our building. A Hampshire Alumni himself!**

**We are excited to move forward on yet another BIG project on Big Red! I hope that this new information and updated bids fills your requirements for a new Grant for The KAVE!**

**Thank you for your time,**

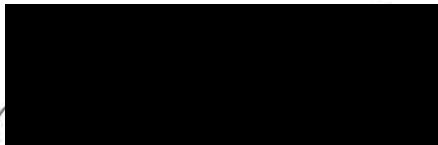

**Gina Pearson and David Ruth**

BID #1

MLE ENTERPRISES IS  
KAVES CHOICE & PREFERENCE  
TO DO THIS JOB. MLE HAS  
DONE OUR PAST FACADE  
IMPROVEMENT JOBS & THEY LOOK  
GREAT!

**EST3607**

Date: Oct 8, 2024

ESTIMATE TO:  
**Bob Pearson**  
 123 Washington Ave  
 Hampshire IL  
 60140  
 bobpearson31@gmail.com

#	Item	Unit Price	Qty	Total
01	<b>Custom Made American Craftsman Replacement Windows</b> Custom made American Craftsman replacement casement windows. Low E glass Argon filled, black exterior white interior	\$897.20	18	\$16,149.60
02	<b>New Steel Door</b> New Jeld-Wen pre hung 6 panel door	\$280.13	1	\$280.13
03	<b>Door amd Window Installation</b> •Remove and replace existing entry door •Remove and dispose of current windows and boarded up window openings in back •Replace any damaged jams as needed •Reframe boarded up openings •Install 18 windows •Install window foam as needed	\$15,000.00	1	\$15,000.00
04	<b>Masonry</b> •Install and supply new concrete sill on one boarded up unit •Tuckpoint brick around windows •Tuckpoint all sills	\$2,529.27	1	\$2,529.27
05	<b>Aluminum Cladding Install</b> •Wrap exterior wood on sides and top arch with Black Aluminum •Caulk all windows and aluminum with black Quad exterior caulk	\$1,891.00	1	\$1,891.00
Subtotal				\$35,850.00
<b>Grand Total</b>				<b>\$35,850.00</b>

Thank you!

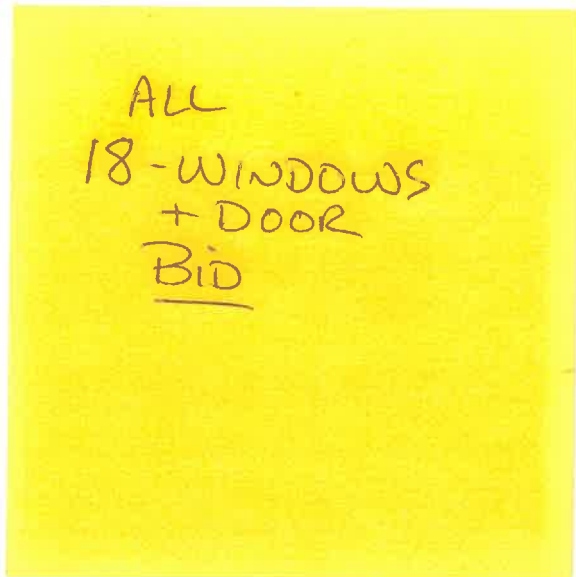

*Mark Ellett*

ESTIMATE TO:  
**Bob Pearson**  
 123 Washington Ave  
 Hampshire IL  
 60140  
 bobpearson31@gmail.com

**EST3608**

Date: Oct 8, 2024

#	Item	Unit Price	Qty	Total
01	<b>Custom Made American Craftsman Replacement Windows</b> Custom made American Craftsman replacement casement windows. Low E glass Argon filled, black exterior white interior	\$897.20	9	\$8,074.80
02	<b>New Steel Door</b> New Jeld-Wen pre hung 6 panel door	\$280.13	1	\$280.13
03	<b>Door and Window Installation</b> •Remove and replace existing entry door •Remove and dispose of current windows •Replace any damaged jams as needed •Reframe boarded up openings •Install 18 windows •Install window foam as needed	\$8,550.00	1	\$8,550.00
04	<b>Masonry</b> •Tuckpoint brick around windows •Tuckpoint sills for new windows	\$1,600.00	1	\$1,600.00
05	<b>Aluminum Cladding Install</b> •Wrap exterior wood on sides and top arch with Black Aluminum •Caulk all windows and aluminum with black Quad exterior caulk	\$1,491.00	1	\$1,491.00
Subtotal				\$19,995.93
Grand Total				\$19,995.93

Thank you!

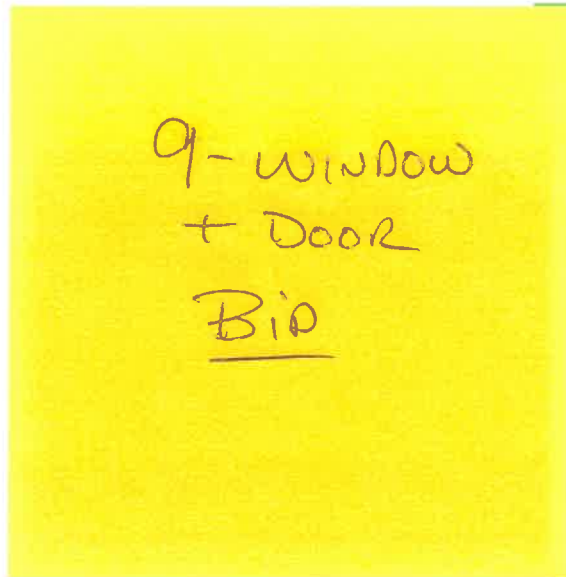

*Matt Ellett*

# The Home Depot Special Order Quote

Customer Agreement #: H1948-115318

Printed Date: 10/8/2024

**Customer:** MATT ELLETT

**Address:**

**Phone:** 815-375-8989

**Email:** MJELLETT1@GMAIL.COM

**Store:** 1948

**Associate:** CHARLES

**Address:** 251 Spring Hill Rd  
Carpentersville, IL 60110

**Phone:** (847)783-0766

**Pre-Savings Total:** \$14,816.16

**Total Savings:** (\$0.00)

**Pre-Tax Price:** \$14,816.16

**Tax -** 1,333.44

**TOTAL #** 16,149.60

All prices are subject to change. Customer is responsible for verifying product selections. The Home Depot will not accept returns for the below products.



Catalog Version 7AS

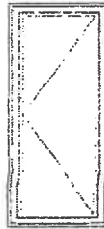

Standard Width = RO: 28 7/8" | UNIT: 28 3/8"

Standard Height = RO: 65 5/16" | UNIT: 64 13/16"

Frame Width = 28 3/8

Frame Height = 64 813/1000

Line Number	Item Summary	Room Location	Was Price	New Price	Quantity	Total Savings	Total Price
100-1	70 Series NF Single Casement-70NCW1, Left, 28.375 x 64.813, Black Painted / White, FL# 21335	Second Floor	\$823.12	\$823.12	18	\$0.00	\$14,816.16
			<del>\$823.12</del>	<del>\$823.12</del>		<del>\$0.00</del>	<del>\$14,816.16</del>

**Begin Line 100 Description**

**--- Line 100-1 ---**

70 Series NF Single Casement-70NCW1  
 Overall Rough Opening = 28 7/8" x 65 5/16"  
 Overall Unit = 28 3/8" x 64 13/16"  
 Installation Zip Code = 60140  
 U.S. ENERGY STAR® Climate Zone = Northern  
 ENERGY STAR Required = No  
 Standard Width = RO: 28 7/8" | UNIT: 28 3/8"  
 Standard Height = RO: 65 5/16" | UNIT: 64 13/16"  
 Frame Width = 28 3/8  
 Frame Height = 64 813/1000  
 Unit Code = 24x54  
 Venting / Hanging = Left  
 Hinge Style = Hinge with Wash Mode  
 Hinge Type = Standard

Exterior Color = Black Painted  
 Interior Finish Color = White  
 Performance Rating = PG30  
 Glass Construction Type = Dual Pane  
 Glass Option = Low-E SC Argon  
 High Altitude Breather Tubes = No  
 Glass Strength = Standard  
 Glass Tint = Gray  
 Specialty Glass = None  
 Gas Fill = Argon  
 None  
 Insect Screen Type = Full Screen  
 Drywall Return = No  
 Extension Jamb Type = None

Room Location = Second Floor  
 Unit U-Factor = 0.27  
 Unit Solar Heat Gain Coefficient (SHGC) = 0.2  
 U.S. ENERGY STAR Certified = No  
 Florida Product Approval Number (FL#) = 21335  
 Clear Opening Width = 16.187  
 Clear Opening Height = 59.563  
 Clear Opening Area = 6.6955  
 SKU = 1001796703  
 SKU Description = S/O AC 70 CASEMENT LONG LT  
 Vendor Name = S/O SILVER LINE BLDG PRD  
 Vendor Number = 60660514  
 Customer Service = (866) 486-1222  
 Catalog Version Date = 07/18/2024

**End Line 100 Description**

EXISTING DOOR TO BE REPLACED



ABOVE DOOR,  
BRICK IN  
NEED OF  
REPAIR &  
TUCK POINTING.



SOUTH  
WALL WHERE WINDOWS  
ARE BOARDED UP, &  
NEW WINDOWS WILL  
HAVE TO BE  
FRAMED IN.

THERE ARE 6  
WINDOW OPENINGS  
ON THE SOUTH WALL.

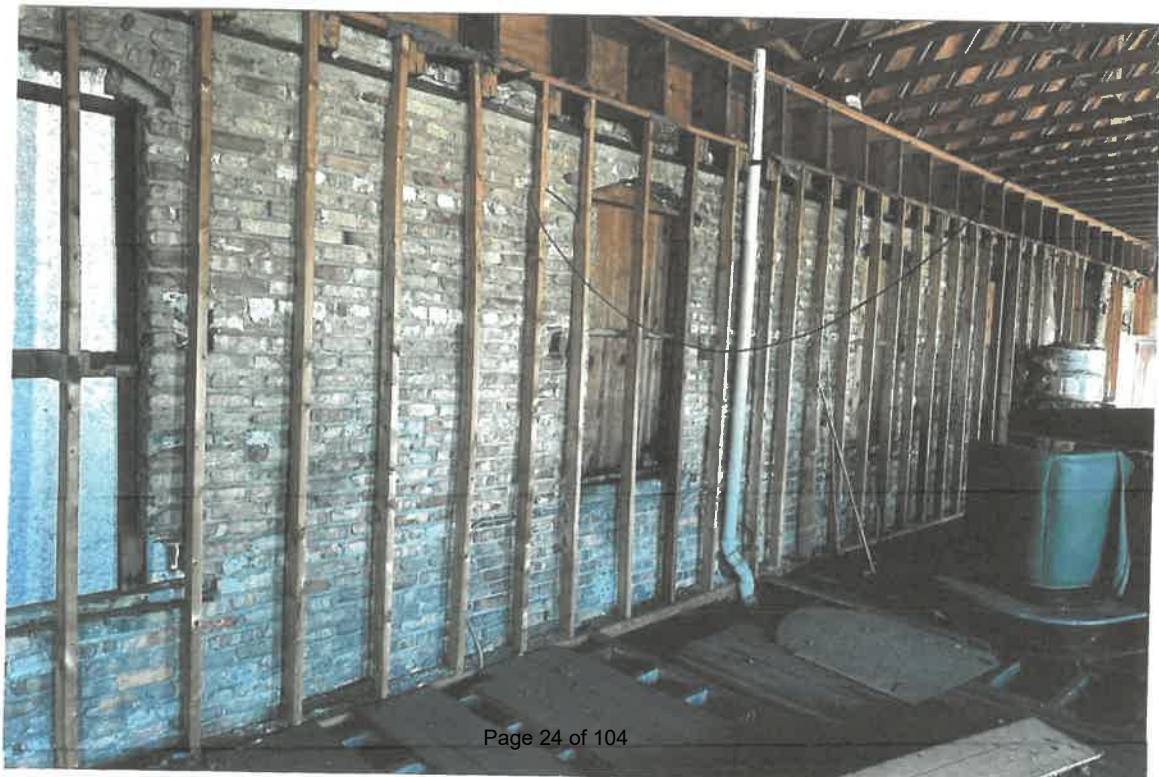





ONE OF THE WINDOW  
OPENINGS  
ON THE WEST  
WALL.

1 of 3 window  
openings

WEST WALL -  
THERE ARE 3 WINDOW  
OPENINGS THAT ARE BOARDED  
UP. NEED FRAMING TO ACCEPT  
NEW WINDOWS.



Bid #2

---

## Estimate - Notification from Jeff Zopfi

---

Heit Construction <quickbooks@notification.intuit.com>

Thu, Oct 10, 2024 at 1:54 PM

Reply-To: jeff@heitconstruction.com

To: bobpearson31@gmail.com

ESTIMATE 1378 DETAILS



Heit Construction

**\$38,690.00**

Review and approve

Powered by QuickBooks

Dear Valued Client,

Please find your sales form below. If you need to remit payment, please do so at your earliest convenience.

Thank you for your business - we appreciate it very much.

Sincerely,

Jeff Zopfi

**Address**

Kave  
123 Washington Ave.

**Services**

**\$30,400.00**

Remove (18) windows on second story of building and replace with Lindsay vinyl casement windows.  
All windows to be black with black hardware.  
Wrap new window trim with aluminum

**Services**

**\$1,090.00**

Remove existing door and replace with new custom cut down door, 33- 1/2" x 78-3/4"

**Services**

**\$7,200.00**

Repair brick where needed around window openings

---

**Total      \$38,690.00**

Review and approve

Heit Construction

P.O. box 902 Hampshire IL 60140 Hampshire, IL 60140

+1 8478156136    [jeff@heitconstruction.com](mailto:jeff@heitconstruction.com)

---

If you receive an email that seems fraudulent, please check with the business owner before paying.

---

---

## AGENDA SUPPLEMENT

---

---

**TO:** President Reid and Village Board

**FROM:** Lori Lyons, Finance Director

**FOR:** November 21, 2024 Village Board Meeting

**RE:** Resolution Determining the Request of \$1,605,600.00 to be Levied for the 2024 Tax Year through Real Estate Taxes for the Village

---

**Background.** The resolution determining the amount of fund to be levied for the 2024 tax year through real estate taxes is attached for your review. Each year corporate authorities for the Village of Hampshire are required to estimate the revenue required to conduct the various functions of the Village. Included in the revenues are those funded through property taxes. Therefore, the Village must estimate the amount required for the property tax levy so that the funds generated through this revenue instrument will become available during the upcoming fiscal year. The estimated levy must be approved by the Village Board and submitted to the County Clerks in both Kane and McHenry counties by the last Tuesday in December.

**Analysis.** The 2024 levy request is for \$1,605,600, an increase of 15% over the last year's adjusted extension of \$1,396,167. In March 2025, the County Clerk will provide the limiting extension and if the Village's requested has exceeded the tax extension limitation, the levy amount will be reduced accordingly. If the EAV and new construction values met staff estimate, it is expected that the extension will be reduced by more than \$60,000 upon applying the limitation calculation. It is always best to request more than is expected to be received based on the estimated EAVs and the new construction estimates that are published on the Kane County Tax Extension website and McHenry County Clerk's website. If the levy request does not meet or exceed the limitation figure, the Village will not have the ability to increase the levy to make up the difference without a referendum. It's crucial that the original request be higher than the anticipated levy extension in order to capture all new growth in the community and the property tax revenue the Villate is authorized to receive under the Property Tax Extension Limitation Law or PTELL.

Since the proposed tax levy request reflects an increase of more than 5% when compared to the previous extension a public hearing is required for the 2024 tax levy request. It is proposed the public hearing be held on December 19, 2024. Consideration of the tax levy ordinance is also scheduled for the same meeting date. A schedule of the levy process follows the resolution referenced above.

**Recommendation.** Staff recommends approval of the attached resolution setting the levy request for 2024 (collection in 2025) at \$1,605,600 and setting the public hearing for December 19, 2204.



Resolution 24-XX

DETERMINING THE AMOUNT OF FUNDS TO BE LEVIED  
FOR THE 2024 TAX YEAR THROUGH REAL ESTATE TAXES  
FOR THE VILLAGE OF HAMPSHIRE, KANE and MCHENRY COUNTIES, ILLINOIS

**WHEREAS**, the Village of Hampshire historically levies taxes for the purpose of conducting Village business for its residents and local businesses; and

**WHEREAS**, it has been determined the requested levy amount is an increase of fifteen percent (15.0%) over the 2023 levy amount; and

**WHEREAS**, it is in the interest of the Village of Hampshire for the 2024 tax levy request to not exceed 115 percent of the 2023 tax year extension; and

**WHEREAS**, a Public Hearing as required by the Truth in Taxation Act of 1981 will be held on December 19, 2024; and

**WHEREAS**, consideration of the Tax Levy Ordinance has been scheduled for December 19, 2024 at the regular meeting of the Hampshire Village Board.

**NOW THEREFORE, BE IT RESOLVED BY THE PRESIDENT AND VILLAGE BOARD OF THE VILLAGE OF HAMPSHIRE, KANE AND MCHENRY COUNTIES, ILLINOIS** that it has determined the amount of taxes to be levied by the Village of Hampshire exclusive of elections costs, shall be 1,605,600.

ADOPTED THIS 21<sup>st</sup> day of November 2024, pursuant to a roll call vote as follows:

AYES:

NAYS:

ABSTAIN:

ABSENT:

APPROVED by the Village President and Board of Trustees of the Village of Hampshire this 21<sup>ST</sup> day of November 2024.

---

Michael J. Reid, Jr., Village President

Attest:

---

Karen Stuehler, Village Clerk

**2024 Property Tax Levy Process  
(Collected in 2025)**

**November 2024**

- Municipalities must estimate the revenues required from property taxes and consider a levy estimate at a public meeting which must be approved by the majority of the elected body. The estimate must be considered at least 20 days prior to the consideration and passage of the tax levy ordinance. Resolution on the agenda for the second Village Board Meeting in November (21 days prior to the scheduled consideration and approval of the tax levy ordinance). 11/21/2024
  
- Notice of the levy amount must be posted either at the top of the Village's website home page or must be available by a link from the home page for not less than 30 days. 11/15/2024
  
- If the estimated levy is more than 105% of the prior year's levy amount, the municipality must hold a public hearing prior to the passage of the tax levy ordinance. A notice of the hearing must also be published. The notice must be published not more than 14 or less than 7 days prior to the public hearing. Publication of hearing notice scheduled following the second meeting of Village Board in November. Publication of hearing  
scheduled between 12/5  
& 12/12/2024

**December 2024**

- The public hearing is held prior to the passage of the tax levy ordinance. During the hearing, the corporate authorities are required to explain the reasons for the proposed increase. Public comments must also be permitted. Public hearing will be scheduled for night of the first December Village Board Meeting at the start 7:00 Board Meeting. Public hearing scheduled  
for 12/19/2024
  
- Upon closure of the public hearing, the Village can immediately consider a tax levy ordinance. The tax levy ordinance must be passed and filed with the County Clerk no later than the last Tuesday of December . the goal is to file before the week of the Christmas holiday. Tax levy ordinance on  
agenda for 12/19/24. Tax  
levy request filed with  
the Co Clerks by 12/31/24

**March 2025**

- The County Clerk finalizes the compilation of the Equalized Assessed Valuation statistics in March.
  
- The County Clerk evaluates the Village's levy request in light of property tax extension and limitation legislation (levy, exclusive of new growth and annexations, cannot increase more than 5% or the rate of inflation whichever is less).

**April 2025**

- The County Clerk applies the limitation criteria and resubmits the extension to the Village for review.
  
- The Village reviews the limitation information, makes any changes desired, and resubmits (usually within 24 hours).
  
- The County Clerks issue the final tax levy information.



---

---

## AGENDA SUPPLEMENT

---

---

**TO:** President Reid and Village Board

**FROM:** Lori Lyons, Finance Director

**FOR:** November 21, 2024 Village Board Meeting

**RE:** Authorization to Purchase a Snow Plow/Dump Truck

---

**Background.** The FY26 operating budget and Village Capital Plan will include the acquisition of a new Snow Plow/Dump truck to aid snow and other operations in the Street Division. Following this agenda supplement, you will find a map of the snow plow routes and a listing of drivers and routes. As the Village grows, additional personnel and equipment is required for the safety and security of our residents. The plowing of streets in Prairie Ridge North's neighborhoods T, Z & AA will necessitate the addition of another truck in the Village's fleet.

Supply chain problems forced makers to stop or limit the production of new trucks in the last 4-5 years and while production appears to have somewhat increased it is still very difficult to obtain a truck in a manner considered timely. The Village has been provided with a unique opportunity as Street Supervisor David Starrett has been working with Duane Schaefers of Transchicago Truck Group (TCTG) in Elmhurst. TCTG is a Freightliner dealer. Mr. Schaefers was able to find a build spot for February 2025 for a new 2025 Freightliner cab and chassis. Assuming the spot is available upon execution of the proposal attached, the truck will likely be at the dealership awaiting upfitting at the beginning of FY2026. Due to the long lead time, staff is asking the Board to authorize the purchase at this time. This TCTG proposal is off of a Sourcewell cooperative purchasing contract eliminating the need for further competitive bidding.

**Analysis.** The truck specifications are detailed on the TCTG proposal that also follows this agenda supplement. The cost of the cab and chassis is \$122,747.00. Additional upfitting will be required to (dump bed, ice control applicators, plow, etc.) Staff will return with that cost and information at a future meeting.

**Recommendation.** Staff requests authorization by resolution to sign the quotation document for a new 2025 Freightliner plow truck cab and chassis at a purchase cost of \$122,747.00.

**No. 24 – XX**

**A RESOLUTION APPROVING THE PURCHASE OF A  
2024 FREIGHTLINER 108SD PLUS  
FOR THE VILLAGE OF HAMPSHIRE**

WHEREAS, THE Village of Hampshire, Kane and McHenry Counties, Illinois (the “Village”) is a duly organized and existing municipal corporation created under the provisions of the laws of the State of Illinois and under the provisions of the Illinois Municipal Code, as from time to time supplemented and amended; and

WHEREAS, the Village is in need of a plow truck to provide public works services to the community; and

WHEREAS, Village staff has reviewed options in obtaining a truck that satisfies the Village’s specifications and will best address the Village’s need, and

WHEREAS, Village has the opportunity to obtain a build spot in February 2025 for a 2025 Freightliner 108SD Plus Cab and Chassis (Truck) through Transchicago Truck Group of Elmhurst, Illinois (Vendor), and

WHEREAS, the Village is a member of Sourcewell a public agency that provides cooperative purchasing solutions for government and educational agencies, and

WHEREAS, Sourcewell has identified the Vendor as a qualified bidder and awarded a contract to the Vendor for the purchase of the Truck in the amount of \$122,747.00, and

WHEREAS, Village staff has determined that Sourcewell’s purchasing policies satisfy all competitive bidding requirements, and

WHEREAS, the Village will budget sufficient funds in the Fiscal Year 2025 budget for the purchase of the Truck, and

WHEREAS, the President and Trustees of the Village of Hampshire have determined that it is in the best interest of the Village and the public to approve the purchase of the Truck from the Vendor as set for in this resolution:

**NOW, THEREFORE, BE IT RESOLVED BY THE PRESIDENT AND BOARD OF TRUSTEES OF THE VILLAGE OF HAMPSHIRE, KANE AND MCHENRY COUNTIES, ILLINOIS, AS FOLLOWS:**

Section one. The purchase of a 2025 Freightliner 109SD Plus cab and chassis for snow operations as specified and detailed in Exhibit A attached hereto and incorporated herein by this reference is hereby approved.

Section two. The Village Manager, or his designee, is authorized to execute, on behalf of the Village, all documents acceptable and necessary to complete the purchase of the Truck from Vendor as authorized by pursuant to this Ordinance.

Section two. This resolution shall take full force and effect upon its passage and approval as provided by law.

ADOPTED THIS 21<sup>st</sup> day of November 2024, pursuant to roll call vote as follows:

AYES: \_\_\_\_\_

NAYS: \_\_\_\_\_

ABSTAIN: \_\_\_\_\_

ABSENT: \_\_\_\_\_

APPROVED THIS 21<sup>st</sup> day of November 2024.

\_\_\_\_\_  
Michael J. Reid, Jr.  
Village President

ATTEST:

\_\_\_\_\_  
Karen Stuehler  
Village Clerk

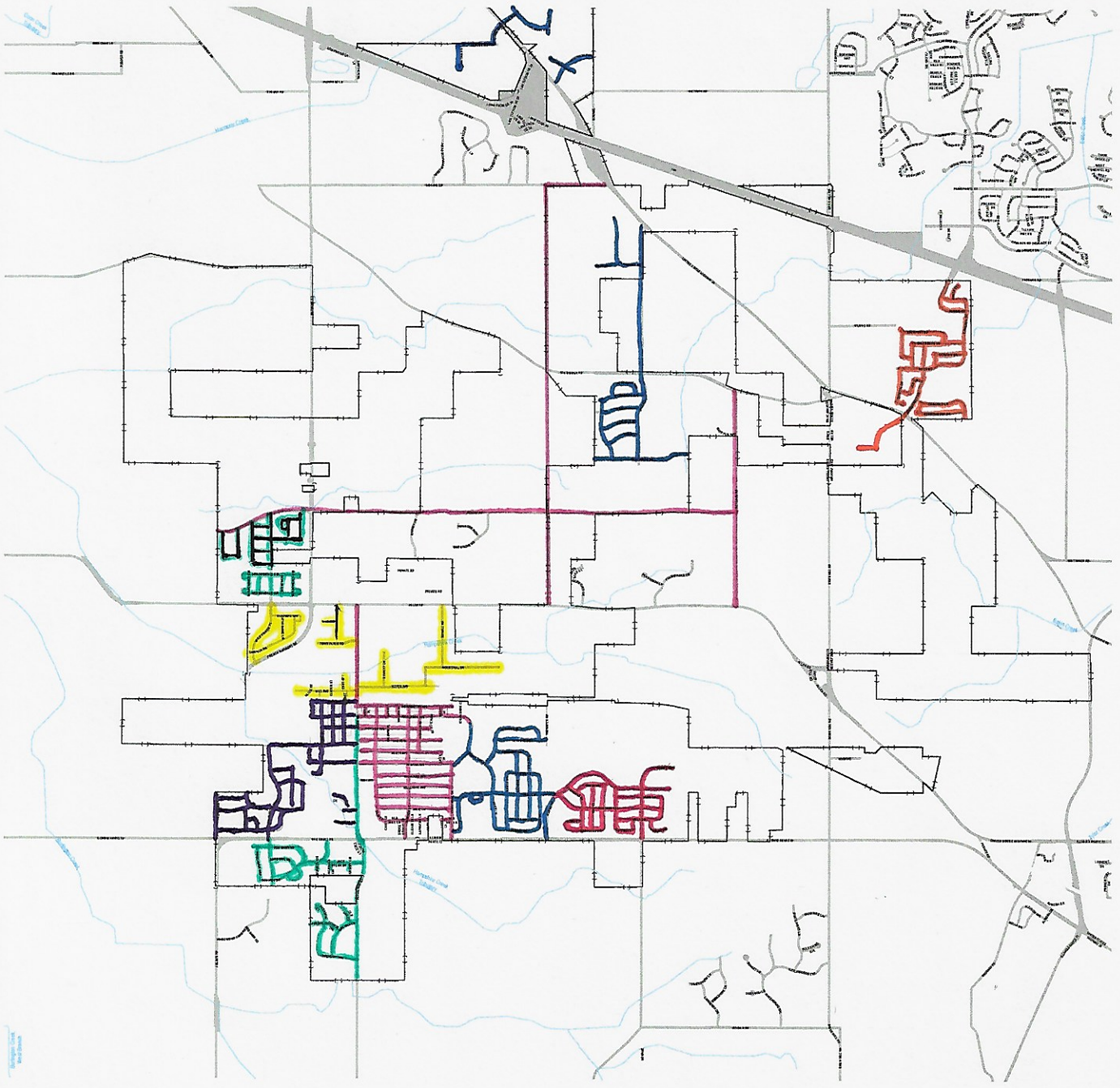

**Engineering Enterprises, Inc.**  
 52 Wheeler Road  
 Sugar Grove, Illinois 60554  
 (630) 466-6700  
[www.eeivet.com](http://www.eeivet.com)

**Village of Hampshire**  
 224 S. State Street  
 Hampshire, IL 60140  
[www.hampshireil.org](http://www.hampshireil.org)

DATE:	8/10/17 2:10
PROJECT NO.:	11111111
BY:	JAC
PATH:	H:\GIS\DATA\HAMP\HAMP2019
FILE:	HAMP_2019_Maps.mxd



**Street Map  
 2019**



# Snow Plow Routes 2024 / 2025

1. **Bill Panzloff** – Old Town West and Hampshire Prairie (Purple)
2. **Garrett Ferrell** – Hills, Fields, Meadows, Getzelman rd and State st south of downtown (Green south of downtown)
3. **Andy Kasiba** – Lakewood Crossing and Big Timber school (Orange)
4. **Adam Schumacher** – Kelley rd, Widmayer, Ketchum rd, portion of Higgins and State st north of downtown (Magenta)
5. **Jake Bell** – Gast rd from the High School to rt 20, Hampshire Business Park and the Truck Stop. Jake will also be plowing Tamms Farm next year (Blue)
6. **Dawid Szlag** – Stonegate and Prairie Ridge Neighborhood L,K and M (Green north of downtown)
7. **Sean Horne** – Parkside, Terrabrook, Wyndam, Town Place rd and the Industrial Park (Yellow)
8. **Tony Bachara** – Tuscany Woods (Red)
9. **Austin Collins** – Old Mill Manor and Old Town East (Magenta)
10. **Christian Jones** – Hampshire Highlands and White oak Ponds (Blue)
11. **Dalton Collins** – Alleys, Parking lots, Street Scape and shovel front and back of Village Hall.
12. **New Employee for additional truck** – Prairie Ridge Neighborhood T, Z and AA

**No. 24 – XX**

**A RESOLUTION APPROVING THE PURCHASE OF A  
2024 FREIGHTLINER 108SD PLUS  
FOR THE VILLAGE OF HAMPSHIRE**

WHEREAS, THE Village of Hampshire, Kane and McHenry Counties, Illinois (the “Village”) is a duly organized and existing municipal corporation created under the provisions of the laws of the State of Illinois and under the provisions of the Illinois Municipal Code, as from time to time supplemented and amended; and

WHEREAS, the Village is in need of a plow truck to provide public works services to the community; and

WHEREAS, Village staff has reviewed options in obtaining a truck that satisfies the Village’s specifications and will best address the Village’s need, and

WHEREAS, Village has the opportunity to obtain a build spot in February 2025 for a 2025 Freightliner 108SD Plus Cab and Chassis (Truck) through Transchicago Truck Group of Elmhurst, Illinois (Vendor), and

WHEREAS, the Village is a member of Sourcewell a public agency that provides cooperative purchasing solutions for government and educational agencies, and

WHEREAS, Sourcewell has identified the Vendor as a qualified bidder and awarded a contract to the Vendor for the purchase of the Truck in the amount of \$122,747.00, and

WHEREAS, Village staff has determined that Sourcewell’s purchasing policies satisfy all competitive bidding requirements, and

WHEREAS, the Village will budget sufficient funds in the Fiscal Year 2025 budget for the purchase of the Truck, and

WHEREAS, the President and Trustees of the Village of Hampshire have determined that it is in the best interest of the Village and the public to approve the purchase of the Truck from the Vendor as set for in this resolution:

**NOW, THEREFORE, BE IT RESOLVED BY THE PRESIDENT AND BOARD OF TRUSTEES OF THE VILLAGE OF HAMPSHIRE, KANE AND MCHENRY COUNTIES, ILLINOIS, AS FOLLOWS:**

Section one. The purchase of a 2025 Freightliner 109SD Plus cab and chassis for snow operations as specified and detailed in Exhibit A attached hereto and incorporated herein by this reference is hereby approved.

Section two. The Village Manager, or his designee, is authorized to execute, on behalf of the Village, all documents acceptable and necessary to complete the purchase of the Truck from Vendor as authorized by pursuant to this Ordinance.

Section two. This resolution shall take full force and effect upon its passage and approval as provided by law.

ADOPTED THIS 21<sup>st</sup> day of November 2024, pursuant to roll call vote as follows:

AYES: \_\_\_\_\_

NAYS: \_\_\_\_\_

ABSTAIN: \_\_\_\_\_

ABSENT: \_\_\_\_\_

APPROVED THIS 21<sup>st</sup> day of November 2024.

\_\_\_\_\_  
Michael J. Reid, Jr.  
Village President

ATTEST:

\_\_\_\_\_  
Karen Stuehler  
Village Clerk

Prepared for:  
DAVID STARETT  
HAMPSHIRE VILLAGE OF  
234S STATE ST  
PO BOX 457  
HAMPSHIRE, IL 60140  
Phone: 847-683-9489

Prepared by:  
Duane Schaefer  
TRANSHICAGO TRUCK  
GROUP  
776 N. YORK STREET  
ELMHURST, IL 60126  
Phone: 815-509-9079

*A proposal for*  
**HAMPSHIRE VILLAGE OF**  
*For CY25MY26*  
**Customer Draft # 3**

*Prepared by*  
**TRANSHICAGO TRUCK GROUP**  
*Duane Schaefer*

*Oct 29, 2024*

**Freightliner 108SD Plus**



Components shown may not reflect all spec'd options and are not to scale





Prepared for:  
 DAVID STARETT  
 HAMPSHIRE VILLAGE OF  
 234S STATE ST  
 PO BOX 457  
 HAMPSHIRE, IL 60140  
 Phone: 847-683-9489

Prepared by:  
 Duane Schaefer  
 TRANSCHICAGO TRUCK  
 GROUP  
 776 N. YORK STREET  
 ELMHURST, IL 60126  
 Phone: 815-509-9079

## S P E C I F I C A T I O N   P R O P O S A L

Description	Weight Front	Weight Rear
<b>Price Level</b>		
SD PRL-29D (EFF:MY26 ORDERS)		
<b>Data Version</b>		
SPECPRO21 DATA RELEASE VER 015		
<b>Vehicle Configuration</b>		
108SD PLUS CONVENTIONAL CHASSIS	6,829	3,748
2026 MODEL YEAR SPECIFIED		
SET BACK AXLE - TRUCK		
TOWING PROVISION AT END OF FRAME WITH SAE J560, WITHOUT END OF FRAME AIR CONNECTIONS	15	15
LH PRIMARY STEERING LOCATION		
<b>General Service</b>		
TRUCK/TRAILER CONFIGURATION		
DOMICILED, USA 50 STATES (INCLUDING CALIFORNIA AND CARB OPT-IN STATES)		
CARB CLEAN IDLE LABELS NOT FOR INITIAL REGISTRATION IN STATES REQUIRING CARB EMISSIONS CERTIFICATION (INCLUDES 6X4 INCH LABELS ON LOWER FORWARD OF DRIVER DOOR)		
UTILITY/REPAIR/MAINTENANCE SERVICE		
GOVERNMENT BUSINESS SEGMENT		
DIRT/SAND/ROCK COMMODITY		
TERRAIN/DUTY: 100% (ALL) OF THE TIME, IN TRANSIT, IS SPENT ON PAVED ROADS		
MAXIMUM 8% EXPECTED GRADE		
SMOOTH CONCRETE OR ASPHALT PAVEMENT - MOST SEVERE IN-TRANSIT (BETWEEN SITES) ROAD SURFACE		
FREIGHTLINER LEVEL III WARRANTY		
EXPECTED FRONT AXLE(S) LOAD : 20000.0 lbs		

Application Version 12.0.009  
 Hampshire MY26 108SD L9 SA  
 24Sept



10/29/2024 12:06 PM

Page 2 of 31

Prepared for:  
 DAVID STARETT  
 HAMPSHIRE VILLAGE OF  
 234S STATE ST  
 PO BOX 457  
 HAMPSHIRE, IL 60140  
 Phone: 847-683-9489

Prepared by:  
 Duane Schaefer  
 TRANSSHICAGO TRUCK  
 GROUP  
 776 N. YORK STREET  
 ELMHURST, IL 60126  
 Phone: 815-509-9079

Description	Weight Front	Weight Rear
EXPECTED REAR DRIVE AXLE(S) LOAD : 23000.0 lbs		
EXPECTED GROSS VEHICLE WEIGHT CAPACITY : 43000.0 lbs		
EXPECTED GROSS COMBINATION WEIGHT : 45000.0 lbs		

**Truck Service**

FRONT PLOW/END DUMP BODY  
 EXPECTED TRUCK BODY LENGTH : 10.0 ft  
 MONROE TRUCK EQUIPMENT

**Engine**

CUM L9 350 HP @ 2200 RPM; 2200 GOV RPM,  
 1050 LB-FT @ 1200 RPM

**Electronic Parameters**

65 MPH ROAD SPEED LIMIT  
 CRUISE CONTROL SPEED LIMIT SAME AS ROAD SPEED LIMIT  
 PTO RPM CONTROL WITH STEERING WHEEL SWITCHES  
 PTO RPM WITH CRUISE RESUME SWITCH - 1100 RPM  
 PTO GOVERNOR RAMP RATE - 25 RPM PER SECOND  
 FUEL DOSING OF AFTERTREATMENT ENABLED IN PTO MODE-CLEANS HYDROCARBONS AT HIGH TEMPERATURES ONLY  
 CRUISE CONTROL BUTTON PTO CONTROL  
 PTO SPEED 1 SETTING - 700 RPM  
 PTO MINIMUM RPM - 700  
 REGEN INHIBIT SPEED THRESHOLD - 5 MPH  
 PTO 1, DASH SWITCH, ENGAGE WHILE DRIVING  
 ENGINE MOUNT PTO, DASH SWITCH ENGAGES PTO MODE, DRIVING OPERATION

**Engine Equipment**

EPA 2010 GHG 2024/CARB 2024 ULTRALOW NOX CONFIGURATION  
 STANDARD OIL PAN  
 OIL FILL AND DIPSTICK LOCATED FOR ENHANCED SERVICEABILITY



Prepared for:  
 DAVID STARETT  
 HAMPSHIRE VILLAGE OF  
 234S STATE ST  
 PO BOX 457  
 HAMPSHIRE, IL 60140  
 Phone: 847-683-9489

Prepared by:  
 Duane Schaefer  
 TRANSCHICAGO TRUCK  
 GROUP  
 776 N. YORK STREET  
 ELMHURST, IL 60126  
 Phone: 815-509-9079

Description	Weight Front	Weight Rear
SIDE OF HOOD AIR INTAKE WITH FIREWALL MOUNTED DONALDSON AIR CLEANER WITH SAFETY ELEMENT AND INSIDE/OUTSIDE AIR WITH SNOW DOOR	10	
DR 12V 160 AMP 28-SI QUADRAMOUNT PAD ALTERNATOR WITH REMOTE BATTERY VOLT SENSE		
(2) DTNA GENUINE, FLOODED STARTING, MIN 2000CCA, 370RC, THREADED STUD BATTERIES		
BATTERY BOX FRAME MOUNTED		
STANDARD BATTERY JUMPERS		
SINGLE BATTERY BOX FRAME MOUNTED LH SIDE UNDER CAB		
WIRE GROUND RETURN FOR BATTERY CABLES WITH ADDITIONAL FRAME GROUND RETURN		
NON-POLISHED BATTERY BOX COVER		
NON-ESSENTIAL POSITIVE LOAD DISCONNECT, IN CAB CONTROL SWITCH MOUNTED OUTBOARD OF DRIVER SEAT	2	
POSITIVE AND NEGATIVE POSTS FOR JUMPSTART LOCATED ON FRAME NEXT TO STARTER	2	
PROGRESSIVE LOW VOLTAGE DISCONNECT AT 12.3 VOLTS FOR DESIGNATED CIRCUITS	2	
CUMMINS TURBOCHARGED 18.7 CFM AIR COMPRESSOR WITH INTERNAL SAFETY VALVE		
ELECTRONIC ENGINE INTEGRAL WARNING AND DERATE PROTECTION SYSTEM		
CUMMINS ENGINE INTEGRAL BRAKE WITH VARIABLE GEOMETRY TURBO ON/OFF	20	
RH OUTBOARD UNDER STEP MOUNTED HORIZONTAL AFTERTREATMENT SYSTEM ASSEMBLY WITH RH B-PILLAR MOUNTED VERTICAL TAILPIPE	30	25
ENGINE AFTERTREATMENT DEVICE, AUTOMATIC OVER THE ROAD ACTIVE REGENERATION AND VIRTUAL REGENERATION REQUEST SWITCH IN CLUSTER AND DASH MOUNTED INHIBIT SWITCH		
10 FOOT 06 INCH (126 INCH+0/-5.9 INCH) EXHAUST SYSTEM HEIGHT		
STANDARD CURVE BRIGHT UPPER STACK(S)		
RH CURVED VERTICAL TAILPIPE B-PILLAR MOUNTED ROUTED FROM STEP		
6 GALLON DIESEL EXHAUST FLUID TANK	-35	-10

Application Version 12.0.009  
 Hampshire MY26 108SD L9 SA  
 24Sept



10/29/2024 12:06 PM

Page 4 of 31

Prepared for:  
 DAVID STARETT  
 HAMPSHIRE VILLAGE OF  
 234S STATE ST  
 PO BOX 457  
 HAMPSHIRE, IL 60140  
 Phone: 847-683-9489

Prepared by:  
 Duane Schaefer  
 TRANSCHICAGO TRUCK  
 GROUP  
 776 N. YORK STREET  
 ELMHURST, IL 60126  
 Phone: 815-509-9079

Description	Weight Front	Weight Rear
100 PERCENT DIESEL EXHAUST FLUID FILL		
STANDARD DIESEL EXHAUST FLUID PUMP MOUNTING		
LH MEDIUM DUTY STANDARD DIESEL EXHAUST FLUID TANK LOCATION		
STANDARD DIESEL EXHAUST FLUID TANK CAP		
STAINLESS STEEL AFTERTREATMENT DEVICE/MUFFLER/TAILOPIPE SHIELD		
AIR POWERED ON/OFF ENGINE FAN CLUTCH		
AUTOMATIC FAN CONTROL WITHOUT DASH SWITCH, NON ENGINE MOUNTED		
CUMMINS SPIN ON FUEL FILTER		
COMBINATION FULL FLOW/BYPASS OIL FILTER		
FLEETGUARD PLAIN COOLANT FILTER		
1115 SQUARE INCH ALUMINUM RADIATOR		
ANTIFREEZE TO -60F, OAT (NITRITE AND SILCATE FREE) EXTENDED LIFE COOLANT		
GATES BLUE STRIPE COOLANT HOSES OR EQUIVALENT		
CONSTANT TENSION HOSE CLAMPS FOR COOLANT HOSES		
RADIATOR DRAIN VALVE		
1350 ADAPTER FLANGE FOR FRONT PTO PROVISION	20	
ELECTRIC GRID AIR INTAKE WARMER		
DELCO 12V 38MT HD STARTER WITH INTEGRATED MAGNETIC SWITCH		

**Transmission**

ALLISON 3000 RDS AUTOMATIC TRANSMISSION WITH PTO PROVISION

**Transmission Equipment**

ALLISON VOCATIONAL PACKAGE 223 - AVAILABLE ON 3000/4000 PRODUCT FAMILIES WITH VOCATIONAL MODELS RDS, HS, MH AND TRV

ALLISON VOCATIONAL RATING FOR ON/OFF HIGHWAY APPLICATIONS AVAILABLE WITH ALL PRODUCT FAMILIES

PRIMARY MODE GEARS, LOWEST GEAR 1, START GEAR 1, HIGHEST GEAR 6, AVAILABLE FOR 3000/4000 PRODUCT FAMILIES ONLY



**Prepared for:**  
 DAVID STARETT  
 HAMPSHIRE VILLAGE OF  
 234S STATE ST  
 PO BOX 457  
 HAMPSHIRE, IL 60140  
 Phone: 847-683-9489

**Prepared by:**  
 Duane Schaefer  
 TRANSCHICAGO TRUCK  
 GROUP  
 776 N. YORK STREET  
 ELMHURST, IL 60126  
 Phone: 815-509-9079

Description	Weight Front	Weight Rear
SECONDARY MODE GEARS, LOWEST GEAR 1, START GEAR 1, HIGHEST GEAR 6, AVAILABLE FOR 3000/4000 PRODUCT FAMILIES ONLY		
S5 PERFORMANCE LIMITING PRIMARY SHIFT SCHEDULE, AVAILABLE FOR 3000/4000 PRODUCT FAMILIES ONLY		
S5 PERFORMANCE LIMITING SECONDARY SHIFT SCHEDULE, AVAILABLE FOR 3000/4000 PRODUCT FAMILIES ONLY		
2200 RPM PRIMARY MODE SHIFT SPEED		
2200 RPM SECONDARY MODE SHIFT SPEED		
2ND GEAR ENGINE BRAKE ALTERNATE PRESELECT WITH MODERATE DOWNSHIFT STRATEGY		
NEUTRAL AT STOP ENABLED		
DRIVER SWITCH INPUT - DEFAULT - NO SWITCHES		
DIRECTION CHANGE ENABLED WITH MULTIPLEXED SERVICE BRAKES - ALLISON 5TH GEN TRANSMISSIONS		
MAXIMUM ENGINE SPEED FOR PTO ENGAGEMENT 900 RPM		
MAXIMUM ENGINE SPEED FOR PTO OPERATION 2700 RPM		
MAXIMUM OUTPUT SPEED FOR PTO ENGAGEMENT 250 RPM		
MAXIMUM OUTPUT SPEED FOR PTO OPERATION 4000 RPM - ALLISON 5TH GEN TRANSMISSIONS		
NO AMT HOLD MODE		
QUICKFIT BODY LIGHTING CONNECTOR UNDER CAB, WITH CAP		
ELECTRONIC TRANSMISSION WIRING TO CUSTOMER INTERFACE CONNECTOR		
CUSTOMER INSTALLED CHELSEA 870 SERIES PTO		
PTO MOUNTING, LH SIDE OF MAIN TRANSMISSION ALLISON		
MAGNETIC PLUGS, ENGINE DRAIN, TRANSMISSION DRAIN, AXLE(S) FILL AND DRAIN		
PUSH BUTTON ELECTRONIC SHIFT CONTROL, DASH MOUNTED		
TRANSMISSION PROGNOSTICS - ENABLED 2013		



Prepared for:  
 DAVID STARETT  
 HAMPSHIRE VILLAGE OF  
 234S STATE ST  
 PO BOX 457  
 HAMPSHIRE, IL 60140  
 Phone: 847-683-9489

Prepared by:  
 Duane Schaefer  
 TRANSSHICAGO TRUCK  
 GROUP  
 776 N. YORK STREET  
 ELMHURST, IL 60126  
 Phone: 815-509-9079

Description	Weight Front	Weight Rear
WATER TO OIL TRANSMISSION COOLER, IN RADIATOR END TANK	15	
TRANSMISSION OIL CHECK AND FILL WITH CROSSOVER TO CLEAR LH PTO AND DIRECT MOUNT PUMP		
SYNTHETIC TRANSMISSION FLUID (TES-295 COMPLIANT)		

### Front Axle and Equipment

DETROIT DA-F-20.0-5 20,000# FL1 71.0 KPI/3.74 DROP SINGLE FRONT AXLE	190	
MERITOR 16.5X6 Q+ CAST SPIDER CAM FRONT BRAKES, DOUBLE ANCHOR, FABRICATED SHOES	10	
NON-ASBESTOS FRONT BRAKE LINING		
CAST IRON OUTBOARD FRONT BRAKE DRUMS		
FRONT BRAKE DUST SHIELDS	5	
FRONT OIL SEALS		
VENTED FRONT HUB CAPS WITH WINDOW, CENTER AND SIDE PLUGS - OIL		
STANDARD SPINDLE NUTS FOR ALL AXLES		
HALDEX AUTOMATIC FRONT SLACK ADJUSTERS WITH STAINLESS STEEL CLEVIS PINS		
STANDARD KING PIN BUSHINGS		
TRW THP-60 POWER STEERING WITH RCH45 AUXILIARY GEAR	130	
POWER STEERING PUMP		
4 QUART POWER STEERING RESERVOIR		
OIL/AIR POWER STEERING COOLER		
CURRENT AVAILABLE SYNTHETIC 75W-90 FRONT AXLE LUBE		

### Front Suspension

20,000# FLAT LEAF FRONT SUSPENSION	310	
GRAPHITE BRONZE BUSHINGS WITH SEALS - FRONT SUSPENSION		
FRONT SUSPENSION WITH LEFT HAND OFFSET SHACKLE BRACKET	4	
FRONT SHOCK ABSORBERS		

### Rear Axle and Equipment

MERITOR RS-23-160 23,000# R-SERIES SINGLE REAR AXLE	180	
---	-----	--

Application Version 12.0.009  
 Hampshire MY26 108SD L9 SA  
 24Sept



10/29/2024 12:06 PM

Page 7 of 31

**Prepared for:**  
 DAVID STARETT  
 HAMPSHIRE VILLAGE OF  
 234S STATE ST  
 PO BOX 457  
 HAMPSHIRE, IL 60140  
 Phone: 847-683-9489

**Prepared by:**  
 Duane Schaefer  
 TRANSCHICAGO TRUCK  
 GROUP  
 776 N. YORK STREET  
 ELMHURST, IL 60126  
 Phone: 815-509-9079

Description	Weight Front	Weight Rear
5.63 REAR AXLE RATIO		
IRON REAR AXLE CARRIER WITH STANDARD AXLE HOUSING		
SPL140HD DANA SPICER MAIN DRIVELINE WITH HALF ROUND YOKES	5	5
DRIVER CONTROLLED TRACTION DIFFERENTIAL - SINGLE REAR AXLE		20
(1) DRIVER CONTROLLED DIFFERENTIAL LOCK REAR VALVE FOR SINGLE DRIVE AXLE		
INDICATOR LIGHT AND BUZZER FOR EACH DIFFERENTIAL LOCKOUT SWITCH, ENGAGE AT SPEEDS 5 MPH PR LESS, DISENGAGE W/IGN OFF OR SPEEDS EXCEEDING 25 MPH		
MERITOR 16.5X7 Q+ CAST SPIDER HEAVY DUTY CAM REAR BRAKES, DOUBLE ANCHOR, FABRICATED SHOES		
NON-ASBESTOS REAR BRAKE LINING		
BRAKE CAMS AND CHAMBERS ON FORWARD SIDE OF DRIVE AXLE(S) WITH AUXILIARY SUPPORT BRACKETS		
CAST IRON OUTBOARD REAR BRAKE DRUMS		-10
REAR BRAKE DUST SHIELDS		5
REAR OIL SEALS		
BENDIX EVERSURE LONGSTROKE 1-DRIVE AXLE SPRING PARKING CHAMBERS		
HALDEX AUTOMATIC REAR SLACK ADJUSTERS WITH STAINLESS STEEL CLEVIS PINS		
CURRENT AVAILABLE SYNTHETIC 75W-90 REAR AXLE LUBE		
STANDARD REAR AXLE BREATHER(S)		

### Rear Suspension

AIRLINER 23,000# REAR SUSPENSION WITH CHAIN CLEARANCE		110
AIRLINER HIGH POSITION RIDE HEIGHT		
STANDARD AXLE SEATS IN AXLE CLAMP GROUP		
IGNITION CONTROLLED ELECTRIC DUMP SWITCH FOR AIR SUSPENSION WITH STATE RETENTION AND GAUGE		
REAR AIR SUSPENSION DUMP VALVE AUTOFILL >5 MPH WITH INDICATOR LIGHT		
DUAL AIR REAR SUSPENSION LEVELING VALVES		
TRANSVERSE CONTROL RODS		



Prepared for:  
 DAVID STARETT  
 HAMPSHIRE VILLAGE OF  
 234S STATE ST  
 PO BOX 457  
 HAMPSHIRE, IL 60140  
 Phone: 847-683-9489

Prepared by:  
 Duane Schaefer  
 TRANSSHICAGO TRUCK  
 GROUP  
 776 N. YORK STREET  
 ELMHURST, IL 60126  
 Phone: 815-509-9079

Description	Weight Front	Weight Rear
REAR SHOCK ABSORBERS - ONE AXLE (AIR RIDE SUSPENSION)		
<b>Pusher / Tag Equipment</b>		
NO PUSHER/TAG BRAKE DUST SHIELDS		
<b>Brake System</b>		
WABCO 4S/4M ABS WITH TRACTION CONTROL WITH ATC SHUT OFF SWITCH		
REINFORCED NYLON, FABRIC BRAID AND WIRE BRAID CHASSIS AIR LINES		
FIBER BRAID PARKING BRAKE HOSE		
STANDARD BRAKE SYSTEM VALVES		
STANDARD AIR SYSTEM PRESSURE PROTECTION SYSTEM		
STD U.S. FRONT BRAKE VALVE		
RELAY VALVE WITH 5-8 PSI CRACK PRESSURE, NO REAR PROPORTIONING VALVE		
BW AD-9 BRAKE LINE AIR DRYER WITH HEATER	20	
AIR DRYER MOUNTED INBOARD ON RH RAIL		
STEEL AIR TANKS MOUNTED AFT INSIDE AND/OR BELOW FRAME JUST FORWARD OF REAR SUSPENSION, NO TRIPLE OR TORPEDO TANKS		
BW DV-2 AUTO DRAIN VALVE WITH HEATER - WET TANK, PETCOCKS ALL OTHERS		
<b>Trailer Connections</b>		
NO TRAILER AIR HOSE		
NO AIR HOSE HANGER		
(2) QUICKFIT PROGRAMMABLE SOLENOIDS W/STATE RETENTION PLUMBED TO BACK OF CAB		
PRIMARY CONNECTOR/RECEPTACLE WIRED FOR SEPARATE STOP/TURN, CENTER PIN POWERED THROUGH IGNITION WITH STOP SIGNAL PREWIRE PACKAGE		
PDI INSTALLED ELECTRIC BRAKE CONTROLLER		
SAE J560 7-WAY PRIMARY TRAILER CABLE RECEPTACLE MOUNTED END OF FRAME		
NO TRAILER ELECTRICAL CABLE		
<b>Wheelbase &amp; Frame</b>		
3825MM (151 INCH) WHEELBASE		





Prepared for:  
 DAVID STARETT  
 HAMPSHIRE VILLAGE OF  
 234S STATE ST  
 PO BOX 457  
 HAMPSHIRE, IL 60140  
 Phone: 847-683-9489

Prepared by:  
 Duane Schaefer  
 TRANSCHICAGO TRUCK  
 GROUP  
 776 N. YORK STREET  
 ELMHURST, IL 60126  
 Phone: 815-509-9079

Description	Weight Front	Weight Rear
7/16X3-9/16X11-1/8 INCH STEEL FRAME (11.11MMX282.6MM/0.437X11.13 INCH) 120KSI TEM TO EVALUATE AND INSTALL FRAME RAIL REINFORCEMENT AS NEEDED FOR FRONT FRAME MOUNTED EQUIPMENT 1750MM (69 INCH) REAR FRAME OVERHANG FRAME OVERHANG RANGE: 61 INCH TO 70 INCH	110	170
24 INCH INTEGRAL FRONT FRAME EXTENSION CALC'D BACK OF CAB TO REAR SUSP C/L (CA) : 85.04 in CALCULATED EFFECTIVE BACK OF CAB TO REAR SUSPENSION C/L (CA) : 82.04 in CALC'D FRAME LENGTH - OVERALL : 284.65 in CALCULATED FRAME SPACE LH SIDE : 49.36 in CALCULATED FRAME SPACE RH SIDE : 53.42 in CALC'D SPACE AVAILABLE FOR DECKPLATE : 0.0 in SQUARE END OF FRAME FRONT CLOSING CROSSMEMBER LIGHTWEIGHT HEAVY DUTY ALUMINUM ENGINE CROSSMEMBER STANDARD MIDSHIP #1 CROSSMEMBER(S) STANDARD REARMOST CROSSMEMBER HEAVY DUTY SUSPENSION CROSSMEMBER	140	-20
	-12	30

### Chassis Equipment

14 INCH PAINTED STEEL BUMPER  
 BUMPER MOUNTING FOR SINGLE LICENSE  
 PLATE  
 NO MUDFLAP BRACKETS  
 NO REAR MUDFLAPS  
 GRADE 8 THREADED HEX HEADED FRAME  
 FASTENERS  
 EXTERIOR HARNESES WRAPPED IN  
 ABRASION TAPE, SECONDARY COVERING, &  
 CONNECTOR PROTECTION  
 D15-16004-000 CENTER PUNCH TO MARK  
 CENTERLINE OF REAR SUSPENSION ON  
 FRAME WEB  
 CLEAR FRAME RAILS FROM BACK OF CAB TO  
 FRONT REAR SUSPENSION BRACKET, BOTH  
 RAILS OUTBOARD



Prepared for:  
 DAVID STARETT  
 HAMPSHIRE VILLAGE OF  
 234S STATE ST  
 PO BOX 457  
 HAMPSHIRE, IL 60140  
 Phone: 847-683-9489

Prepared by:  
 Duane Schaefer  
 TRANSCHICAGO TRUCK  
 GROUP  
 776 N. YORK STREET  
 ELMHURST, IL 60126  
 Phone: 815-509-9079

Description	Weight Front	Weight Rear
<b>Fifth Wheel</b>		
NO FIFTH WHEEL		
<b>Fuel Tanks</b>		
50 GALLON/189 LITER SHORT RECTANGULAR ALUMINUM FUEL TANK - LH RECTANGULAR FUEL TANK(S) PLAIN ALUMINUM/PAINTED STEEL FUEL/HYDRAULIC TANK(S) WITH PAINTED BANDS FUEL TANK(S) FORWARD POLISHED STEP FINISH FUEL TANK CAP(S)	-10	
DAVCO 245 FUEL/WATER SEPARATOR WITH 12 VOLT HEAT AND WATER IN FUEL SENSOR EQUIFLO INBOARD FUEL SYSTEM HIGH TEMPERATURE REINFORCED NYLON FUEL LINE	5	
<b>Tires</b>		
CONTINENTAL HAU 3 WT 315/80R22.5 20 PLY RADIAL FRONT TIRES	100	
CONTINENTAL HDR2+ 11R22.5 14 PLY RADIAL REAR TIRES		92
<b>Hubs</b>		
CONMET PRESET PLUS PREMIUM IRON FRONT HUBS CONMET PRESET PLUS PREMIUM IRON REAR HUBS		
<b>Wheels</b>		
MAXION WHEELS 10041 22.5X9.00 10-HUB PILOT 5.25 INSET 5-HAND STEEL DISC FRONT WHEELS	66	
MAXION WHEELS 90260 22.5X8.25 10-HUB PILOT 2-HAND HD STEEL DISC REAR WHEELS FRONT WHEEL MOUNTING NUTS REAR WHEEL MOUNTING NUTS WHEEL STUDS FOR CUSTOMER INSTALLED HUB PILOTED DUALED ALUMINUM WHEELS, ALL		80
<b>Cab Exterior</b>		
108 INCH BBC FLAT ROOF ALUMINUM CONVENTIONAL CAB		



**Prepared for:**  
 DAVID STARETT  
 HAMPSHIRE VILLAGE OF  
 234S STATE ST  
 PO BOX 457  
 HAMPSHIRE, IL 60140  
 Phone: 847-683-9489

**Prepared by:**  
 Duane Schaefer  
 TRANSCHICAGO TRUCK  
 GROUP  
 776 N. YORK STREET  
 ELMHURST, IL 60126  
 Phone: 815-509-9079

Description	Weight Front	Weight Rear
AIR CAB MOUNTING		
CAB ROOF REINFORCEMENTS FOR ROOF MOUNTED COMPONENTS	2	
NONREMOVABLE BUGSCREEN MOUNTED BEHIND GRILLE		
SHORT FENDER WITH MUDFLAP		
BOLT-ON MOLDED FLEXIBLE FENDER EXTENSIONS	10	
SAFETY YELLOW LH AND RH INTERIOR GRAB HANDLES AND LH AND RH EXTERIOR GRAB HANDLES WITH SINGLE RUBBER INSERT		
STATIONARY BLACK GRILLE		
BLACK HOOD MOUNTED AIR INTAKE GRILLE		
FIBERGLASS HOOD WITH ACCESS HATCHES	10	
CAB FLOOR, TOE BOARD AND FIREWALL HEAT SHIELD	5	
SINGLE 14 INCH ROUND HADLEY AIR HORN UNDER LH DECK		
SINGLE ELECTRIC HORN		
REAR LICENSE PLATE MOUNT END OF FRAME		
HALOGEN COMPOSITE HEADLAMPS WITH BLACK BEZELS		
LED AERODYNAMIC MARKER LIGHTS		
WIRING AND SWITCH FOR CUSTOMER FURNISHED SNOW PLOW LAMPS WITH SINGLE CONNECTION AT LH FORWARD		
DAYTIME RUNNING LIGHTS		
INTEGRAL STOP/TAIL/BACKUP LIGHTS		
STANDARD FRONT TURN SIGNAL LAMPS		
DUAL WEST COAST MOLDED-IN COLOR HEATED MIRRORS WITH LH AND RH REMOTE		
DOOR MOUNTED MIRRORS		
102 INCH EQUIPMENT WIDTH		
LH AND RH 8 INCH MOLDED-IN COLOR CONVEX MIRRORS MOUNTED UNDER PRIMARY MIRRORS		
RH AND LH 8 INCH HEATED STAINLESS STEEL FENDER MOUNTED CONVEX MIRRORS WITH TRIPOD BRACKETS	12	
STANDARD SIDE/REAR REFLECTORS		
RH AFTERTREATMENT SYSTEM CAB ACCESS WITH POLISHED DIAMOND PLATE COVER		



Prepared for:  
 DAVID STARETT  
 HAMPSHIRE VILLAGE OF  
 234S STATE ST  
 PO BOX 457  
 HAMPSHIRE, IL 60140  
 Phone: 847-683-9489

Prepared by:  
 Duane Schaefer  
 TRANSCHICAGO TRUCK  
 GROUP  
 776 N. YORK STREET  
 ELMHURST, IL 60126  
 Phone: 815-509-9079

Description	Weight Front	Weight Rear
2-STAGE ELECTRIC HORN AND HAZARD LAMP ALERT CONTROLLED BY PARTICULATE FILTER REGENERATION REQUIRED STATUS		
63X14 INCH TINTED REAR WINDOW		
TINTED DOOR GLASS LH AND RH WITH TINTED OPERATING WING WINDOWS		
RH AND LH ELECTRIC POWERED WINDOWS		
1-PIECE BONDED HEATED WIPER PARK SOLAR GREEN GLASS WINDSHIELD		
8 LITER (2 GAL) WINDSHIELD WASHER RESERVOIR, CAB MOUNTED, WITH FLUID LEVEL INDICATOR		
<b>Cab Interior</b>		
RUGGED TRIM PACKAGE		
GRAY & CARBON VINYL INTERIOR "RUGGED"		
CARBON WITH PREMIUM GUNMETAL ACCENT (RUGGED)		
MOLDED PLASTIC DOOR PANEL		
MOLDED PLASTIC DOOR PANEL		
BLACK MATS WITH SINGLE INSULATION		
(1)DASH MOUNTED 12V POWER OUTLET, (1)DASH MOUNTED DUAL USB-C OUTLET		
FORWARD ROOF MOUNTED CONSOLE		
CENTER STORAGE CONSOLE MOUNTED ON BACKWALL	20	
LH AND RH KICKPLATES		
DIGITAL ALARM CLOCK IN DRIVER DISPLAY		
(2) CUP HOLDERS LH AND RH DASH		
M2/SD DASH		
HEATER, DEFROSTER AND AIR CONDITIONER		
STANDARD HVAC DUCTING WITH SNOW SHIELD FOR FRESH AIR INTAKE		
MAIN HVAC CONTROLS WITH RECIRCULATION SWITCH		
STANDARD HEATER PLUMBING WITH BALL SHUTOFF VALVES AT SUPPLY LINES ONLY		
VALEO HEAVY DUTY A/C REFRIGERANT COMPRESSOR		
BINARY CONTROL, R-134A		
PREMIUM INSULATION		
SOLID-STATE CIRCUIT PROTECTION AND FUSES		



Prepared for:  
 DAVID STARETT  
 HAMPSHIRE VILLAGE OF  
 234S STATE ST  
 PO BOX 457  
 HAMPSHIRE, IL 60140  
 Phone: 847-683-9489

Prepared by:  
 Duane Schaefer  
 TRANSCHICAGO TRUCK  
 GROUP  
 776 N. YORK STREET  
 ELMHURST, IL 60126  
 Phone: 815-509-9079

	Description	Weight Front	Weight Rear
	12V NEGATIVE GROUND ELECTRICAL SYSTEM		
	PREMIUM LED CAB LIGHTING		
	NO SECURITY DEVICE		
	DOOR LOCKS AND IGNITION SWITCH KEYED THE SAME		
	KEY QUANTITY OF 4		
	LH AND RH ELECTRIC DOOR LOCKS WITH AUTO UNLOCK FEATURE WHEN DOOR IS SET FROM OPEN TO CLOSED POSITION		
	NO MATTRESS	-20	-15
	BASIC ISRINGHAUSEN HIGH BACK AIR SUSPENSION DRIVERS SEAT WITH MECHANICAL LUMBAR AND INTEGRATED CUSHION EXTENSION	30	
N	BASIC ISRINGHAUSEN HIGH BACK AIR SUSPENSION PASSENGER SEAT WITH MECHANICAL LUMBAR AND INTEGRATED CUSHION EXTENSION	25	10
	DUAL DRIVER AND PASSENGER SEAT ARMRESTS	8	
	LH AND RH INTEGRAL DOOR PANEL ARMRESTS		
	BLACK CORDURA PLUS CLOTH DRIVER SEAT COVER		
	BLACK CORDURA PLUS CLOTH PASSENGER SEAT COVER		
	HIGH VISIBILITY ORANGE SEAT BELTS		
	ADJUSTABLE TILT AND TELESCOPING STEERING COLUMN		
	4-SPOKE 18 INCH (450MM) BLACK STEERING WHEEL WITH SWITCHES		
	DRIVER AND PASSENGER INTERIOR SUN VISORS		

### Instruments & Controls

- \* 4 EXTRA PROGRAMMABLE SWITCHES/INDICATORS
- \$C1B0082ZZ,C1C0083ZZ,C1D0084ZZ,C1E0085ZZ
- ELECTRONIC ACCELERATOR CONTROL
- NO INSTRUMENT PANEL-DRIVER
- FULLY CONFIGURABLE CENTER INSTRUMENT PANELS
- ENGINE REMOTE INTERFACE WITHOUT INTERLOCKS
- BRIGHT ARGENT FINISH GAUGE BEZELS



Prepared for:  
 DAVID STARETT  
 HAMPSHIRE VILLAGE OF  
 234S STATE ST  
 PO BOX 457  
 HAMPSHIRE, IL 60140  
 Phone: 847-683-9489

Prepared by:  
 Duane Schaefer  
 TRANSCHICAGO TRUCK  
 GROUP  
 776 N. YORK STREET  
 ELMHURST, IL 60126  
 Phone: 815-509-9079

Description	Weight Front	Weight Rear
LOW AIR PRESSURE INDICATOR LIGHT AND AUDIBLE ALARM		
DUAL NEEDLE PRIMARY AND SECONDARY AIR PRESSURE GAUGE		
NO AIR CLEANER RESTRICTION GAUGE		
97 DB BACKUP ALARM MOUNTED INBOARD OF RAIL		3
ELECTRONIC CRUISE CONTROL WITH CONTROLS ON STEERING WHEEL SPOKES		
KEY OPERATED IGNITION SWITCH AND INTEGRAL START POSITION; 4 POSITION OFF/RUN/START/ACCESSORY		
PREMIUM INSTRUMENT CLUSTER WITH 5.0 INCH TFT COLOR DISPLAY		
DIGITAL PANEL LAMP DIMMER SWITCH IN DRIVER DISPLAY		
HEAVY DUTY ONBOARD DIAGNOSTICS INTERFACE CONNECTOR LOCATED BELOW LH DASH		
2 INCH ELECTRIC FUEL GAUGE		
ENGINE REMOTE INTERFACE FOR REMOTE THROTTLE		
QUICKFIT POWERTRAIN INTERFACE CONNECTOR UNDER CAB WITH CAPS		
QUICKFIT PROGRAMMABLE INTERFACE CONNECTOR 1 UNDER CAB, CONNECTOR 2 BETWEEN SEATS, BOTH W/CAPS		
ENGINE REMOTE INTERFACE CONNECTOR AT POWERTRAIN INTERFACE CONNECTOR		
ELECTRICAL ENGINE COOLANT TEMPERATURE GAUGE		
ELECTRIC ENGINE OIL PRESSURE GAUGE		
DIGITAL TRANSMISSION OIL TEMPERATURE IN DRIVER DISPLAY		
ELECTRONIC OUTSIDE TEMPERATURE SENSOR DISPLAY IN DRIVER MESSAGE CENTER		
ENGINE AND TRIP HOUR METERS INTEGRAL WITHIN DRIVER DISPLAY		
PTO CONTROLS FOR ENHANCED VEHICLE ELECTRIC/ELECTRONIC ARCHITECTURE		
NO OBSTACLE DETECTION SYSTEM		
NO DR ASSIST SYSTEM		



**Prepared for:**  
 DAVID STARETT  
 HAMPSHIRE VILLAGE OF  
 234S STATE ST  
 PO BOX 457  
 HAMPSHIRE, IL 60140  
 Phone: 847-683-9489

**Prepared by:**  
 Duane Schaefer  
 TRANSCHICAGO TRUCK  
 GROUP  
 776 N. YORK STREET  
 ELMHURST, IL 60126  
 Phone: 815-509-9079

Description	Weight Front	Weight Rear
ELECTRONIC STABILITY CONTROL,4X2 W/SAFETY MIN BODY WEIGHT EXCEEDS 4,000LBS REQ  NO LANE DEPARTURE WARNING SYSTEM  NO REVERSE PROXIMITY SENSOR  NO OVERHEAD INSTRUMENT PANEL  1 QUIKFIT PROGRAMABLE MODULE (QPMXMC) W/ (8) 20AMP FUSED RELAYS  GENERIC TELEMATICS PREWIRE (CONSTANT BATTERY POWER/IGNITION/GROUND/J1939); RP1226 TYPE CONNECTOR AT PASSENGER SIDE OF DASH  7" B-PANEL INTERACTIVE TOUCHSCREEN DISPLAY RADIO W/ USB-C, APPLE CARPLAY, ANDROID AUTO, BLUETOOTH/AM/FM/SXM/WB, WITH MICROPHONE  DASH MOUNTED RADIO  (2) RADIO SPEAKERS IN CAB  NO AM/FM RADIO ANTENNA  NO CB RADIO MOUNTING PROVISION  SHARKFIN MULTI-BAND ANTENNA: AM/FM/WEATHERBAND, WIFI/BLUETOOTH, SDAR/SIRIUSXM, GNSS/GPS  INTEROPERABLE SDAR ANTENNA  ELECTRONIC MPH SPEEDOMETER WITH SECONDARY KPH SCALE, WITHOUT ODOMETER  STANDARD VEHICLE SPEED SENSOR  ELECTRONIC 3000 RPM TACHOMETER  DETROIT CONNECT PLATFORM HARDWARE  3 YEARS DAIMLER CONNECTIVITY BASE PACKAGE ON (FEATURES VARY BY MODEL) POWERED BY DETROIT CONNECT ON CUMMINS ENGINES  NO ASE DATA SVCE EXTENSION  NO EXTENSIONS  TMC RP1226 ACCESSORY CONNECTOR LOCATED BEHIND PASSENGER SIDE REMOVEABLE DASH PANEL  IGNITION SWITCH CONTROLLED ENGINE STOP  NO HARDWIRE SWITCH #1  NO HARDWIRE SWITCH #2  NO HARDWIRE SWITCH #3		



Prepared for:  
 DAVID STARETT  
 HAMPSHIRE VILLAGE OF  
 234S STATE ST  
 PO BOX 457  
 HAMPSHIRE, IL 60140  
 Phone: 847-683-9489

Prepared by:  
 Duane Schaefer  
 TRANSCHICAGO TRUCK  
 GROUP  
 776 N. YORK STREET  
 ELMHURST, IL 60126  
 Phone: 815-509-9079

Description	Weight Front	Weight Rear
PRE-TRIP INSPECTION FEATURE FOR EXTERIOR LAMPS AND SERVICE BRAKES (1) OVERHEAD MOUNTED LANYARD CONTROL FOR DRIVER AIR HORN NO TRAILER HAND CONTROL BRAKE VALVE DIGITAL TURBO AIR PRESSURE IN DRIVER DISPLAY DIGITAL VOLTAGE DISPLAY INTEGRAL WITH DRIVER DISPLAY SINGLE ELECTRIC WINDSHIELD WIPER MOTOR WITH DELAY WHEN PARK BRAKE SET, TRANSITION TO SLOWEST SPEED ROTARY HEADLAMP SWITCH, MARKER LIGHTS/HEADLIGHTS SWITCH WITH PULL OUT FOR OPTIONAL FOG/ROAD LAMPS ONE VALVE PARKING BRAKE SYSTEM WITH WARNING INDICATOR SELF CANCELING TURN SIGNAL SWITCH WITH DIMMER, HEADLAMP FLASH, WASH/WIPE/INTERMITTENT INTEGRAL ELECTRONIC TURN SIGNAL FLASHER WITH 40 AMP (20 AMP PER SIDE) TRAILER LAMP CAPACITY NO WRG/SW-OPTL #2, CHAS, AIR		

**Design**

PAINT: ONE SOLID COLOR

**Color**

CAB COLOR A: L0006EY WHITE ELITE EY  
 BLACK, HIGH SOLIDS POLYURETHANE CHASSIS  
 PAINT  
 POWDER BLACK (N0001EA) FRONT  
 WHEELS/RIMS (PKBLK21, BK, PB1)  
 POWDER BLACK (N0001EA) REAR  
 WHEELS/RIMS (PKBLK21, BK, PB1)  
 STANDARD BLACK BUMPER PAINT  
 STANDARD E COAT/UNDERCOATING

**Certification / Compliance**

U.S. FMVSS CERTIFICATION, EXCEPT SALES  
 CABS AND GLIDER KITS

**Secondary Factory Options**

CORPORATE PDI CENTER OPTION  
 INSTALLATION/MODIFICATION ONLY





**Prepared for:**  
 DAVID STARETT  
 HAMPSHIRE VILLAGE OF  
 234S STATE ST  
 PO BOX 457  
 HAMPSHIRE, IL 60140  
 Phone: 847-683-9489

**Prepared by:**  
 Duane Schaefer  
 TRANSCHICAGO TRUCK  
 GROUP  
 776 N. YORK STREET  
 ELMHURST, IL 60126  
 Phone: 815-509-9079

## TOTAL VEHICLE SUMMARY

### Weight Summary

	Weight Front	Weight Rear	Total Weight
Factory Weight <sup>+</sup>	8085 lbs	4438 lbs	12523 lbs
Total Weight <sup>+</sup>	8085 lbs	4438 lbs	12523 lbs

### Extended Warranty

CUMMINS ENGINE CARB COMPLIANT: L9 HD1 MD DTY 6 YEARS /  
 150,000 MILES / 241,500 KM EXTENDED WARRANTY. FEX APPLIES  
 CUMMINS AFTERTREATMENT CARB22: L9 AT3 MD DTY 6 YEARS /  
 150,000 MILES / 241,500 KM EXTENDED WARRANTY. FEX APPLIES  
 ALLISON 3000 RDS SERIES TRANSMISSION EXTEND WARRANTY, 5  
 YEARS/UNLIMITED MILES FEX  
 TOWING: 6 MONTHS/UNLIMITED MILES/KM EXTENDED TOWING  
 COVERAGE \$750 CAP FEX APPLIES

(+) Weights shown are estimates only.

If weight is critical, contact Customer Application Engineering.

(\*\*\*) All cost increases for major components (Engines, Transmissions, Axles, Front and Rear Tires) and government mandated requirements, tariffs, and raw material surcharges will be passed through and added to factory invoices.



Prepared for:  
 DAVID STARETT  
 HAMPSHIRE VILLAGE OF  
 234S STATE ST  
 PO BOX 457  
 HAMPSHIRE, IL 60140  
 Phone: 847-683-9489

Prepared by:  
 Duane Schaefer  
 TRANSSHICAGO TRUCK  
 GROUP  
 776 N. YORK STREET  
 ELMHURST, IL 60126  
 Phone: 815-509-9079

## D I M E N S I O N S

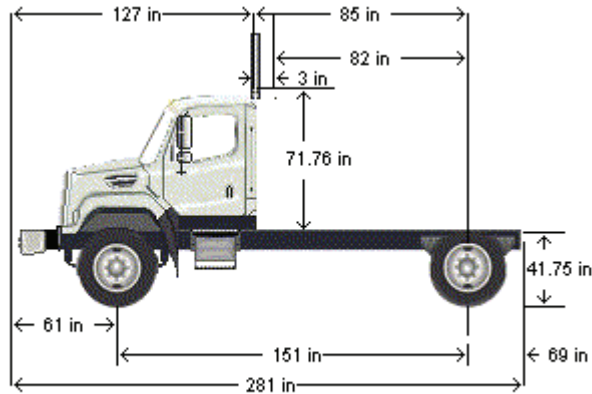

### VEHICLE SPECIFICATIONS SUMMARY - DIMENSIONS

Wheelbase (545) .....	3825MM (151 INCH) WHEELBASE
Rear Frame Overhang (552).....	1750MM (69 INCH) REAR FRAME OVERHANG
Fifth Wheel (578).....	NO FIFTH WHEEL
Mounting Location (577) .....	NO FIFTH WHEEL LOCATION
Maximum Forward Position (in).....	0
Maximum Rearward Position (in) .....	0
Amount of Slide Travel (in).....	0
Slide Increment (in).....	0
Desired Slide Position (in).....	0.0
Cab Size (829).....	108 INCH BBC FLAT ROOF ALUMINUM CONVENTIONAL CAB
Sleeper (682).....	NO SLEEPER BOX/SLEEPER CAB
Exhaust System (016) .....	RH OUTBOARD UNDER STEP MOUNTED HORIZONTAL AFTERTREATMENT SYSTEM ASSEMBLY WITH RH B-PILLAR MOUNTED VERTICAL TAILPIPE



**Prepared for:**  
 DAVID STARETT  
 HAMPSHIRE VILLAGE OF  
 234S STATE ST  
 PO BOX 457  
 HAMPSHIRE, IL 60140  
 Phone: 847-683-9489

**Prepared by:**  
 Duane Schaefer  
 TRANSCHICAGO TRUCK  
 GROUP  
 776 N. YORK STREET  
 ELMHURST, IL 60126  
 Phone: 815-509-9079

**TABLE SUMMARY - DIMENSIONS**

Dimensions	Inches
Bumper to Back of Cab (BBC)	127.0
Bumper to Centerline of Front Axle (BA)	61.4
Front Axle to Back of Cab (AC)	65.6
Min. Cab to Body Clearance (CB)	3.0
Back of Cab to Centerline of Rear Axle(s) (CA)	85.0
Effective Back of Cab to Centerline of Rear Axle(s) (Effective CA)	82.0
Back of Cab Protrusions (Exhaust/Intake) (CP)	2.0
Back of Cab Protrusions (Side Extenders/Trim Tab) (CP)	0.0
Back of Cab Protrusions (CNG Tank)	0.0
Back of Cab Clearance (CL)	3.0
Back of Cab to End of Frame	153.9
Cab Height (CH)	71.8
Wheelbase (WB)	150.6
Frame Overhang (OH)	68.9
Overall Frame Length	284.6
Overall Length (OAL)	280.9
Rear Axle Spacing	0.0
Unladen Frame Height at Centerline of Rear Axle	41.8

Performance calculations are estimates only. If performance calculations are critical, please contact Customer Application Engineering.



**Prepared for:**  
 DAVID STARETT  
 HAMPSHIRE VILLAGE OF  
 234S STATE ST  
 PO BOX 457  
 HAMPSHIRE, IL 60140  
 Phone: 847-683-9489

**Prepared by:**  
 Duane Schaefer  
 TRANSCHICAGO TRUCK  
 GROUP  
 776 N. YORK STREET  
 ELMHURST, IL 60126  
 Phone: 815-509-9079

**G V W R**

**VEHICLE SPECIFICATIONS SUMMARY - GVWR**

Cab Size (829)..... 108 INCH BBC FLAT ROOF ALUMINUM CONVENTIONAL CAB  
 Expected Front Axle(s) Load (lbs)..... 20000.0  
 Expected Pusher Axle(s) Load (lbs)..... 0.0  
 Expected Rear Axle(s) Load (lbs)..... 23000.0  
 Expected Tag Axle(s) Load (lbs)..... 0.0  
 Expected GVW (lbs)..... 43000  
 Expected GCW (lbs)..... 45000.0  
 Front Axle (400)..... DETROIT DA-F-20.0-5 20,000# FL1 71.0 KPI/3.74 DROP SINGLE FRONT AXLE  
 Front Suspension (620)..... 20,000# FLAT LEAF FRONT SUSPENSION  
 Front Hubs (418)..... CONMET PRESET PLUS PREMIUM IRON FRONT HUBS  
 Front Disc Wheels (502) MAXION WHEELS 10041 22.5X9.00 10-HUB PILOT 5.25 INSET 5-HAND STEEL DISC FRONT WHEELS  
 Front Tires (093)..... CONTINENTAL HAU 3 WT 315/80R22.5 20 PLY RADIAL FRONT TIRES  
 Front Brakes (402)..... MERITOR 16.5X6 Q+ CAST SPIDER CAM FRONT BRAKES, DOUBLE ANCHOR, FABRICATED SHOES  
 Steering Gear (536)..... TRW THP-60 POWER STEERING WITH RCH45 AUXILIARY GEAR  
 Rear Axle (420)..... MERITOR RS-23-160 23,000# R-SERIES SINGLE REAR AXLE  
 Rear Suspension (622)..... AIRLINER 23,000# REAR SUSPENSION WITH CHAIN CLEARANCE  
 Rear Hubs (450)..... CONMET PRESET PLUS PREMIUM IRON REAR HUBS  
 Rear Disc Wheels (505)..... MAXION WHEELS 90260 22.5X8.25 10-HUB PILOT 2-HAND HD STEEL DISC REAR WHEELS  
 Rear Tires (094)..... CONTINENTAL HDR2+ 11R22.5 14 PLY RADIAL REAR TIRES  
 Rear Brakes (423) . MERITOR 16.5X7 Q+ CAST SPIDER HEAVY DUTY CAM REAR BRAKES, DOUBLE ANCHOR, FABRICATED SHOES  
 Pusher / Tag Axle (443)..... NO PUSHER OR TAG AXLE  
 Pusher / Tag Suspension (626)..... NO PUSHER OR TAG SUSPENSION  
 Pusher / Tag Hubs (449)..... NO PUSHER OR TAG HUBS  
 Dead/Pusher/Tag Disc Wheels (509)..... NO PUSHER/TAG DISC WHEELS  
 Pusher / Tag Tires (095)..... NO PUSHER/TAG TIRES  
 Pusher / Tag Brakes (456)..... NO PUSHER/TAG BRAKES



**Prepared for:**  
 DAVID STARETT  
 HAMPSHIRE VILLAGE OF  
 234S STATE ST  
 PO BOX 457  
 HAMPSHIRE, IL 60140  
 Phone: 847-683-9489

**Prepared by:**  
 Duane Schaefer  
 TRANSSHICAGO TRUCK  
 GROUP  
 776 N. YORK STREET  
 ELMHURST, IL 60126  
 Phone: 815-509-9079

**TABLE SUMMARY - GVWR**

	Front	Rear
<b>Axle Component Weight Ratings</b>		
Axles	20000	23000
Suspension	20000	23000
Hubs	23000	26000
Brakes	20000	23000
Wheels	20000	31200
Tires	20000	23360
Power Steering	22000	N/A
GAWR (per axle)	20000	23000
GAWR (per axle system)	20000	23000
Expected Load (per axle system)	20000	23000
GVWR due to Frame	90000	
GVWR due to Transmission	80000	
<b>Vehicle GVWR Summary</b>		
Calculated GVWR	43000	
Expected GVWR	43000	
<i>All weights displayed in pounds</i>		

Performance calculations are estimates only. If performance calculations are critical, please contact Customer Application Engineering.



**Prepared for:**  
 DAVID STARETT  
 HAMPSHIRE VILLAGE OF  
 234S STATE ST  
 PO BOX 457  
 HAMPSHIRE, IL 60140  
 Phone: 847-683-9489

**Prepared by:**  
 Duane Schaefer  
 TRANSCHICAGO TRUCK  
 GROUP  
 776 N. YORK STREET  
 ELMHURST, IL 60126  
 Phone: 815-509-9079

**F R A M E R B M**

**VEHICLE SPECIFICATIONS SUMMARY - FRAME RBM**

Wheelbase (545) .....3825MM (151 INCH) WHEELBASE  
 Frame Rails (546)..... 7/16X3-9/16X11-1/8 INCH STEEL FRAME (11.11MMX282.6MM/0.437X11.13 INCH) 120KSI(546)  
     Yield Strength (psi) ..... 120000  
     Section Modulus (per rail) (cu in) ..... 21.6  
     RBM (per rail) (lbf-in) ..... 2592000  
 Inner Frame Reinforcement (547)..... NO INNER FRAME REINFORCEMENT  
 Outer Frame Reinforcement (548)..... TEM TO EVALUATE AND INSTALL FRAME RAIL REINFORCEMENT AS NEEDED FOR FRONT FRAME MOUNTED EQUIPMENT

**TABLE SUMMARY - FRAME RBM**

Item	Description / Value
Wheelbase	3825MM (151 INCH) WHEELBASE
Frame	7/16X3-9/16X11-1/8 INCH STEEL FRAME (11.11MMX282.6MM/0.437X11.13 INCH) 120KSI
Inner Frame Reinforcement	NO INNER FRAME REINFORCEMENT
Outer Frame Reinforcement	TEM TO EVALUATE AND INSTALL FRAME RAIL REINFORCEMENT AS NEEDED FOR FRONT
Yield Strength (psi)	120000
Section Modulus - per rail (cu. in.)	21.60
Frame RBM - per rail (lbf-in)	2592000

Performance calculations are estimates only. If performance calculations are critical, please contact Customer Application Engineering.



Prepared for:  
 DAVID STARETT  
 HAMPSHIRE VILLAGE OF  
 234S STATE ST  
 PO BOX 457  
 HAMPSHIRE, IL 60140  
 Phone: 847-683-9489

Prepared by:  
 Duane Schaefer  
 TRANSCHICAGO TRUCK  
 GROUP  
 776 N. YORK STREET  
 ELMHURST, IL 60126  
 Phone: 815-509-9079

## TURNING RADIUS

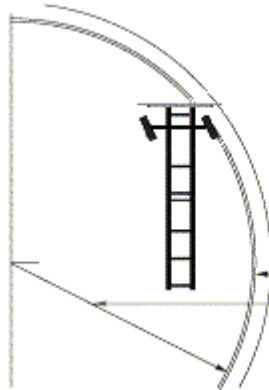

Turning radius graphic and data provided strictly for comparisons between model configurations. Weather, road surfaces, and tire treads affect the results. It is strongly suggested that actual vehicles be measured before constructing any roads/driveways using this information. For specific figures regarding your configuration, please contact your CAE representative.

	Dimensions	Tolerance
Wall to Wall Diameter (ft)	53.9	+/- 3.0
Curb to Curb Diameter (ft)	47.5	+/- 3.0
Turning Radius (ft)	23.2	+/- 1.5

### VEHICLE SPECIFICATIONS SUMMARY - TURNING RADIUS

Cab Size (829)	108 INCH BBC FLAT ROOF ALUMINUM CONVENTIONAL CAB
Wheelbase (545)	3825MM (151 INCH) WHEELBASE
Front Tires (093)	CONTINENTAL HAU 3 WT 315/80R22.5 20 PLY RADIAL FRONT TIRES
Width (in)	12.4
Front Axle (400)	DETROIT DA-F-20.0-5 20,000# FL1 71.0 KPI/3.74 DROP SINGLE FRONT AXLE
Kingpin Intersection (in)	71
Bumper (556)	14 INCH PAINTED STEEL BUMPER
Width (in)	97.6
Bumper Miter to Front Axle (in)	66.112
Primary Steering Location (003)	LH PRIMARY STEERING LOCATION
Steering Gear (536)	TRW THP-60 POWER STEERING WITH RCH45 AUXILIARY GEAR
Dual Steering Gear	RCH45
Ram	NONE
Rear Axle (420)	MERITOR RS-23-160 23,000# R-SERIES SINGLE REAR AXLE
Axle Spacing (624)	NO AXLE SPACING

Performance calculations are estimates only. If performance calculations are critical, please contact Customer Application Engineering.

**Prepared for:**  
DAVID STARETT  
HAMPSHIRE VILLAGE OF  
234S STATE ST  
PO BOX 457  
HAMPSHIRE, IL 60140  
Phone: 847-683-9489

**Prepared by:**  
Duane Schaefer  
TRANSCHICAGO TRUCK  
GROUP  
776 N. YORK STREET  
ELMHURST, IL 60126  
Phone: 815-509-9079

## SWITCH SELECTOR - 4CH - DASH PANEL

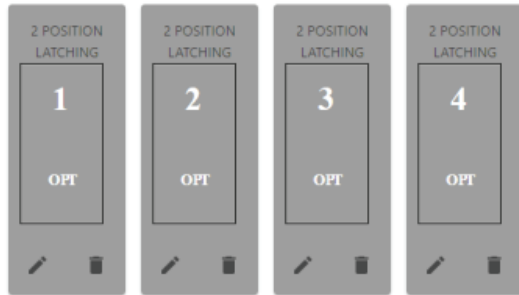



**Prepared for:**  
DAVID STARETT  
HAMPSHIRE VILLAGE OF  
234S STATE ST  
PO BOX 457  
HAMPSHIRE, IL 60140  
Phone: 847-683-9489

**Prepared by:**  
Duane Schaefer  
TRANSCHICAGO TRUCK  
GROUP  
776 N. YORK STREET  
ELMHURST, IL 60126  
Phone: 815-509-9079

**SWITCH SELECTOR - 4Cx - HARDWIRED SWITCHES**

switch #1

switch #2

switch #3

switch #4



**Prepared for:**  
DAVID STARETT  
HAMPSHIRE VILLAGE OF  
234S STATE ST  
PO BOX 457  
HAMPSHIRE, IL 60140  
Phone: 847-683-9489

**Prepared by:**  
Duane Schaefer  
TRANSCHICAGO TRUCK  
GROUP  
776 N. YORK STREET  
ELMHURST, IL 60126  
Phone: 815-509-9079

**SWITCH SELECTOR - 4CG - AUXILIARY  
PANEL**



Prepared for:  
 DAVID STARETT  
 HAMPSHIRE VILLAGE OF  
 234S STATE ST  
 PO BOX 457  
 HAMPSHIRE, IL 60140  
 Phone: 847-683-9489

Prepared by:  
 Duane Schaefer  
 TRANSCHICAGO TRUCK  
 GROUP  
 776 N. YORK STREET  
 ELMHURST, IL 60126  
 Phone: 815-509-9079

## Q U O T A T I O N

### 108SD PLUS CONVENTIONAL CHASSIS

SET BACK AXLE - TRUCK CUM L9 350 HP @ 2200 RPM; 2200 GOV RPM, 1050 LB- FT @ 1200 RPM ALLISON 3000 RDS AUTOMATIC TRANSMISSION WITH PTO PROVISION MERITOR RS-23-160 23,000# R-SERIES SINGLE REAR AXLE AIRLINER 23,000# REAR SUSPENSION WITH CHAIN CLEARANCE DETROIT DA-F-20.0-5 20,000# FL1 71.0 KPI/3.74 DROP SINGLE FRONT AXLE 20,000# FLAT LEAF FRONT SUSPENSION	108 INCH BBC FLAT ROOF ALUMINUM CONVENTIONAL CAB 3825MM (151 INCH) WHEELBASE NO FIFTH WHEEL 7/16X3-9/16X11-1/8 INCH STEEL FRAME (11.11MMX282.6MM/0.437X11.13 INCH) 120KSI 1750MM (69 INCH) REAR FRAME OVERHANG TEM TO EVALUATE AND INSTALL FRAME RAIL REINFORCEMENT AS NEEDED FOR FRONT FRAME MOUNTED EQUIPMENT
--	--

<b>BALANCE DUE – Bare chassis only</b>	<b>(LOCAL CURRENCY) \$</b>	<b>122,747 \$</b>	<b>122,747</b>
<b>Extended warranties on page 18.</b>			

#### ADDITIONAL TERMS AND CONDITIONS

1. As used in this Sales Order the terms (a) Dealer; shall mean the authorized Dealer to whom this Sales Order is addressed and who shall become a party hereto by its acceptance hereof, (b) Purchaser; shall mean the party executing this Sales Order as such on the face hereof, and (c) Manufacturer; shall mean the Corporation that manufactured the vehicle or chassis, it being understood by Purchaser and Dealer that Dealer is not the agent of Manufacturer, that Dealer and Purchaser are the sole parties to this Sales Order and that reference to Manufacturer herein is for the purpose of explaining generally certain contractual relationships existing between Dealer and Manufacturer with respect to new motor vehicles.
2. Manufacturer has reserved the right to change the price the Dealer charges for new motor vehicles without notice. In the event the price to Dealer of a new motor vehicle of the series and body type ordered hereunder is changed by Manufacturer prior to delivery of the new motor vehicle ordered hereunder to Purchaser, Dealer reserves the right to change the cash delivered price of such motor vehicle to Purchaser accordingly.
3. Notwithstanding any terms and conditions contained in Purchaser's Purchase Order, Purchaser agrees that Dealer's terms and conditions set forth in this Sales Order shall be the only terms and conditions regarding any purchase by Purchaser from Dealer. Purchaser expressly waives the provisions of Purchaser's terms and conditions and agrees to be bound exclusively by Dealer's terms and conditions as set forth herein. If Purchaser is an entity, the undersigned represents and warrants to Dealer that the undersigned has authority to bind Purchaser to the terms and conditions outlined herein, and the terms and conditions as outlined herein are enforceable against Purchaser in accordance with their terms.
4. All used motor vehicles which are to be traded in as part of the consideration for the motor vehicle ordered hereunder are subject to Dealer's Trade Terms and Conditions which are incorporated herein by reference. Although Dealer may provide Purchaser with an initial appraisal(s) of the value of and allowance for any used motor vehicle, such initial appraisal and allowance are not binding. Each used motor vehicle shall be reappraised at that time of actual delivery to Dealer for acquisition, and such reappraisal value shall determine the actual allowance made for such motor vehicle. If such reappraised value is lower than the original appraised value and allowance therefor shown on the front of this Sales Order, Purchaser may, if dissatisfied herewith, cancel this Sales Order, provided, however, that such right to cancel must be exercised prior to the delivery of the motor vehicle ordered hereunder to the Purchaser.

Application Version 12.0.009  
 Hampshire MY26 108SD L9 SA  
 24Sept



10/29/2024 12:06 PM

Page 28 of 31

**Prepared for:**  
DAVID STARETT  
HAMPSHIRE VILLAGE OF  
234S STATE ST  
PO BOX 457  
HAMPSHIRE, IL 60140  
Phone: 847-683-9489

**Prepared by:**  
Duane Schaefer  
TRANSCHICAGO TRUCK  
GROUP  
776 N. YORK STREET  
ELMHURST, IL 60126  
Phone: 815-509-9079

5. Purchaser agrees to deliver to Dealer satisfactory evidence of title to any used motor vehicle traded in as part of the consideration for the motor vehicle ordered hereunder at the time of delivery of such used motor vehicle to Dealer. Purchaser warrants any such used motor vehicle to be his or its property free and clear of all liens and encumbrances except as otherwise noted within.

6. Dealer shall have the right, upon failure or refusal of Purchaser to accept delivery of the motor vehicle ordered hereunder or to comply with any of the other terms of this Sales Order, to retain any cash deposit made by Purchaser without the waiver of any other right or remedy available to Dealer.

7. Manufacturer has reserved the right to change the design of any new motor vehicle, chassis, accessories or parts thereof at any time without notice and without obligation to make the same or any similar change upon any motor vehicle, chassis, accessories or parts thereof previously purchased by or shipped to Dealer or being manufactured or sold in accordance with Dealer's orders. Correspondingly, in the event of any such change by Manufacturer, Dealer shall have no obligation to Purchaser to make the same or any similar change in any motor vehicle, chassis, accessories or parts thereof covered by this Sales Order either before or subsequent to delivery thereof to Purchaser.

8. Dealer shall not be liable for failure to deliver or delay in delivering the motor vehicle covered by this Sales Order where such failure or delay is due, in whole or in part, to any cause beyond the control or without the fault or negligence of Dealer.

9. The price for the motor vehicle specified on the face of this Sales Order includes reimbursement for Federal Excise taxes, but does not include sales taxes, use taxes or occupational taxes based on sales volume, (Federal, State or Local) unless expressly so stated. Purchaser assumes and agrees to pay, unless prohibited by law, any such sales, use or occupational taxes imposed on or applicable to the transaction covered by this Sales Order, regardless of which party may have primary tax liability therefor.

10. There are no warranties, whether expressed or implied, made by the Dealer herein, or the Manufacturer, on the vehicle or chassis described on the face hereof except in the case of a new vehicle or chassis for which the warranty shall be limited to such warranty as provided for in writing on the face of this Sales Order or in a separate writing furnished to and signed by Purchaser and Dealer. The printed new vehicle warranty delivered to Purchaser with such vehicle or chassis is made a part hereof as though fully set forth herein, and it is the only warranty applicable to such new vehicle or chassis and is expressly in lieu of all other warranties, whether expressed or implied, including any implied warranty of merchantability or fitness for a particular purpose.

11. Any used motor vehicle sold to Purchaser by Dealer under this Sales Order is sold at the time of delivery by Dealer without any guarantee or warranty, whether expressed or implied, including without limitation, any implied warranty of merchantability or fitness for a particular purpose, as to its condition or the condition of any part thereof except as may be otherwise specifically provided in writing on the face of this Sales Order or in a separate writing furnished to and signed by Purchaser by Dealer.

12. The Purchaser, before or at the time of delivery of the motor vehicle covered by this Sales Order will execute such forms of agreement or documents as may be required by the terms and conditions of payment indicated on the front of this Sales Order.

13. In the event Purchaser desires to modify or otherwise change the equipment content of a vehicle specifically ordered for him from the Manufacturer, the change will be made only if the Manufacturer has sufficient time to accommodate the request. Moreover, any service charge or fee made by the Manufacturer as a result of such request will be borne by the purchaser.

14. The parties agree that they will comply with all Federal, State, and local laws and regulations, including those governing and/or restricting export of products or any technical data relating thereto outside of the United States. In carrying on Purchaser's business, each of Purchaser, its officers, directors, employees or agents (collectively and individually in this clause "Purchaser") must comply with its obligations under the law including without limitation, the following: (a) not violate any anti-bribery or anti-corruption law of any jurisdiction applicable to this Order, including those of the United States of America's Foreign Corrupt Practices Act (FCPA); and any similar anti-corruption or anti-bribery laws and regulations applicable to the Purchaser or related to this Order: (b) not pay, offer or promise to pay, or authorize the payment of, any monies or



**Prepared for:**  
DAVID STARETT  
HAMPSHIRE VILLAGE OF  
234S STATE ST  
PO BOX 457  
HAMPSHIRE, IL 60140  
Phone: 847-683-9489

**Prepared by:**  
Duane Schaefer  
TRANSCHICAGO TRUCK  
GROUP  
776 N. YORK STREET  
ELMHURST, IL 60126  
Phone: 815-509-9079

anything of value, directly or indirectly, to any government official or employee, any official or employee of a state-run or state-owned or controlled enterprise or entity, any official or employee of a public international organization, any candidate for political or public office, any official or employee of any political party, or any family member or relative of such persons or any political party for the purpose of influencing any act or decision of any such official, employee, candidate, political party, enterprise or entity, public organization, or government to obtain or retain business, or direct business to any person or entity, or for any other improper advantage or purpose; (c) warrants that as at the date of this Order, none of its owners, officers, directors, employees or agents or any immediate family member of such persons, is presently (or has been recently) an official or employee of any government, state-run or state-owned or controlled enterprise or entity, or political party, or a candidate for political or public office. Purchaser must provide written notification to Dealer within ten (10) days of any of the above persons becoming such official, employee or candidate; (d) comply with all applicable export and import laws and regulations, including associated embargo and sanction regulations; and (e) certifies that no vehicle or chassis subject to this Order, nor any direct products thereof, will be made available or re-exported, directly or indirectly, by Purchaser (or by any employee or contractor of Purchaser) to any prohibited person, entity or country (including to nationals of any prohibited country, wherever they may be located) unless such prior written authorization as may be required is obtained by Purchaser from the appropriate U.S. government agency(ies), including, as applicable, the U.S. Office of Export Licensing of the U.S. Department of Commerce, in accordance with the U.S. Export Administration Regulations (15 CFR, Parts 779 et seq. or any similar regulation) issued by the Department of Commerce of the United States in the administration of the Export Administration Act of 1979, as amended from time to time, or any subsequently issued similar rule, law or regulation. Purchaser will designate an officer to be responsible for compliance with all such legislation and upon the request of Dealer will certify compliance with such legislation. In the event Purchaser breaches its obligations under this paragraph, or Dealer learns of or has a reasonable suspicion that Purchaser has breached this paragraph, notwithstanding any other provision hereunder to the contrary, Dealer may immediately terminate this Order and Purchaser hereby waives any and all claims against Dealer for any loss, cost or expense, including, but not limited to, loss or profits, incidental or consequential damages, that Purchaser may incur by virtue of such termination.

15. Purchaser shall, from the execution of this Order and for a period of one (1) year after the completion of this Order maintain all records, together with such supporting or underlying documents and materials, related to the motor vehicle ordered hereunder, including but not limited to all records related to the use, the location(s) of such use, the repair and the sale, lease or other transfer of such motor vehicle or any interest therein, as well as Purchaser's compliance with the FCPA and any other applicable anti-corruption or anti-bribery laws or regulations. Purchaser shall at any time requested by Dealer whether during or after completion of this Order, with five (5) days' notice and at Purchaser's own expense make such records available for inspection and audit (including copies and extracts of records as required) by Dealer. Such records shall be made available to Dealer during normal business hours at a time and location that is convenient for Dealer.

16. Documentary Fee. Documentary fee is not an official fee. A documentary fee is not required by law, but may be charged to buyers for handling documents and performing services related to closing of a sale. The base documentary fee beginning 1/1/20 was \$300. The maximum amount that may be charged for a documentary fee is the base documentary fee of \$300, which shall be subject to an annual rate adjustment equal to the percentage of change in the Bureau of Labor Statistics Consumer Price Index. This notice is required by law.

17. Purchaser shall pay on demand all of Dealer's cost and expenses, including its attorney's fees incurred in enforcing the terms of this Sales Order, including but not limited to defending any claims by Purchaser, collecting any payments due hereunder or repossessing the vehicle.

18. The remedies herein reserved shall be cumulative and in addition to any further remedies provided to Dealer whether at law or in equity. No delay or failure by the Dealer to exercise or enforce at any time, any right or provision in this Sales Order, will be considered a waiver thereof or of Dealer's right thereafter to exercise or enforce each and every right and provision of this Sales Order. To be valid, any waiver shall be in writing, but need not be supported by consideration. No single waiver shall constitute a continuing or subsequent waiver.

19. This Sales Order has been negotiated, executed and delivered in Illinois, and shall be construed and enforced in accordance with the laws of the State of Illinois, without reference to the choice of law or conflicts of law principles of any other state.



**Prepared for:**  
DAVID STARETT  
HAMPSHIRE VILLAGE OF  
234S STATE ST  
PO BOX 457  
HAMPSHIRE, IL 60140  
Phone: 847-683-9489

**Prepared by:**  
Duane Schaefer  
TRANSCHICAGO TRUCK  
GROUP  
776 N. YORK STREET  
ELMHURST, IL 60126  
Phone: 815-509-9079

20. Purchaser hereby consents to the exclusive jurisdiction of any state or federal court located in DuPage County, Illinois regarding any disputes regarding this matter. Purchaser waives any trial by jury and waives any objection based on improper venue or forum non conveniens in any action or proceeding to which Purchaser and Dealer may be parties arising out of, or in connection with, or in any way pertaining to this Sales Order. It is agreed and understood by Purchaser that this waiver constitutes a waiver of trial by jury of all claims by Purchaser against the Dealer. This waiver is knowingly, willingly and voluntarily made by Purchaser and Purchaser hereby represents that no representations of fact or opinion have been made by any individual to induce this waiver of trial by jury or to, in any way, modify or nullify its effect. Purchaser further represents and warrants that it either has been represented in the signing of this Sales Order and the making of this Sales Order by the attorney of its choosing, or it has had time to seek independent counsel selected of Purchaser's own free will, and to discuss the terms and conditions of this Sales Order with such counsel.

21. In the event that any provision of this Sales Order shall be deemed to be invalid by reason of the operation of any law or by reason of the interpretation placed on this Sales Order by any court, this Sales Order shall be construed as not containing such provision to the extent of the invalidity and the invalidity of such provision shall not affect the validity of any and all provisions hereby which are otherwise lawful and valid, and such other provisions shall remain in full force and effect.

22. All notices and other communications required hereunder shall be in writing and delivered by personal delivery, overnight delivery service, or certified or registered mail, postage prepaid, return receipt requested. Any such notice shall be deemed to have been given on the date it is received during regular office hours at the address listed on the applicable order or at such other address as the affected party may have previously designated for notices.

23. To the full extent permitted by laws, Purchaser waives all rights against Dealer for any damage to its property or that of third parties, or for injury to any person, however caused. In no event shall Dealer's total liability exceed Dealer's anticipated net profit on the specified purchase price of the vehicles covered by this Sales Order.

24. This Sales Order constitutes the entire agreement between the parties hereto relating to the subject matter hereof and supersedes all prior oral and written and all contemporaneously oral negotiations, commitments and understandings of the parties, except as otherwise expressly set forth in this Sales Order. This Sales Order may not be changed or amended except by writing and executed by both Purchaser and Dealer.

25. Customer must hold title for a minimum of 12 months from retail sale date. Selling trucks earlier will result in volume reduction and a \$ 15,000 per unit penalty. Initial Here \_\_\_\_\_

26. \_\_\_\_\_ units need to be funded within 30 days of arrival at dealership or before shipping if drop shipped. Initial Here \_\_\_\_\_

IN WITNESS WHEREOF, the Purchaser has executed these terms and conditions as of the date herein written below.

\_\_\_\_\_  
Purchaser  
V2020.1

\_\_\_\_\_  
Title

\_\_\_\_\_  
Date





Village of Hampshire  
234 S. State Street, Hampshire IL 60140  
Phone: 847-683-2181      www.hampshireil.org

## Memo to the Board

---

**TO: President Reid; Board of Trustees**  
**FROM: Douglas Pann, Chief of Police**  
**FOR: Village Board Meeting on November 21, 2024**  
**RE: Sale of 2018 Ford Explorer**

---

The Village of Hampshire owns a gray 2018 Ford Explorer which is one of nine vehicles currently in the Police Department fleet. This Ford Explorer was recently replaced with a 2024 Dodge Durango. As a good steward of resources, the Police Department would like to sell this vehicle to partially offset the costs of replacement.

The Explorer was fully equipped as a squad car when in service. At this point, some of the equipment has been transferred to the new squad car; however, the emergency lighting, center console, and other minor equipment remain. The removal of other equipment, such as the prisoner cage has left holes which cannot be repaired. The spotlight remains mounted on the vehicle. The tires are in good condition and do not need to be replaced. The vehicle mileage is 121,134. These conditions reduce the value of the vehicle.

The current Kelley Blue Book (KBB) value of this vehicle is \$11,474 - \$13,827 in good condition.

The Police Department was aware that the Hampshire Township Fire Protection District actively seeks used emergency vehicles, and thus contacted the Fire Protection District to solicit an offer without suggesting a price. After examining the condition of the vehicle and discussing the price with staff, the Hampshire Township Fire Protection District has offered to pay \$10,500 for the vehicle. A \$10,500 sale price is 83% of the mid KBB value.

Police Department staff recommends the sale of the 2018 Ford Explorer to the Hampshire Fire Department for \$10,500.

## Lori Lyons

---

**From:** Trevor Herrmann  
**Sent:** Thursday, November 14, 2024 7:26 AM  
**To:** Douglas Pann  
**Cc:** Eric Larson; James Neblock; sstadie hampshirefire.org  
**Subject:** [EXTERNAL] Vehicle

My board approved purchasing the vehicle, please let us know when its available and we will cut a check for \$10,500.  
Thanks!

*Trevor Herrmann CFO  
Fire Chief  
Hampshire Fire Protection District  
224-629-0382*



**No. 24 - XX**

**AN ORDINANCE  
AUTHORIZING THE SALE OF CERTAIN MUNICIPAL PERSONAL PROPERTY  
(2018 Ford Explorer)  
BY THE VILLAGE OF HAMPSHIRE**

WHEREAS, THE Village of Hampshire, Kane and McHenry Counties, Illinois (the "Village") is a duly organized and existing municipal corporation created under the provisions of the laws of the State of Illinois and under the provisions of the Illinois Municipal Code, as from time to time supplemented and amended; and

WHEREAS, the Village of Hampshire is the owner of a certain motor vehicle, being a 2018 For Explorer, VIN 1FM5K8AR9JGC43256, which had in the past been utilized by the Police Department; and

WHEREAS, said vehicle has exceeded it useful life in the Village and the Hampshire Police Department has no other need for the motor vehicle; and

WHEREAS, the Corporate Authorities have therefore determined that the motor vehicle is not necessary or useful to the Village and that the best interests of the Village would be served by the sale and conveyance of said vehicle; and

WHEREAS, the Village is authorized under the Illinois Municipal Code, Section 11-76-4, to authorize the sale of personal property in such manner as the corporate authorities may designated, with or without advertising the sale; and

WHEREAS, the Village will sell the vehicle for the sum of Ten Thousand, Five Hundred and no/100 dollars (\$10,000.00).

NOW THEREFORE, BE IT ORDAINED BY THE PRESIDENT AND BOARD OF TRUSTEES OF THE VILLAGE OF HAMPSHIRE, KANE AND MCHENRY COUNTIES, ILLINOIS AS FOLLOWS:

Section 1. Pursuant to Section 11-76-4 of the Illinois Municipal Code, 65 ILCS 5/11-76-4, the Corporate Authorities determine and find that the following described personal property, to wit: a 2018 Ford Explorer VIN: 1FM5K8AR9JGC43256, now owned by the Village, is no longer necessary or useful to the Village and the best interests of the Village will be served by its sale.

Section 2. The Village shall be and hereby is authorized and directed to transfer and sell said personal property to the Hampshire Fire Protection District., Hampshire, IL for the sum

of Ten Thousand Five Hundred and no/100 dollars (\$10,500.00), and the Village Finance Director shall be and hereby is authorized to execute and deliver to the Buyer the appropriate Motor Vehicle and/or Bill of Sale, upon receipt of said sum.

Section 3. Any and all ordinances, resolutions, and orders, or parts thereof, which are in conflict with the provisions of this Ordinance, to the extent of any such conflict, are hereby superseded and waived.

Section 4. If any section, subdivision, sentence or phrase of this Ordinance is for any reason held to be void, invalid, or unconstitutional, such decision shall not affect the validity of the remaining portions of this Ordinance.

Section 5. This Ordinance shall be in full force and effect from and after its passage and approval as provided by law.

ADOPTED THIS 21<sup>st</sup> day of November, 2024, pursuant to roll call vote as follows:

AYES: \_\_\_\_\_

NAYS: \_\_\_\_\_

ABSENT: \_\_\_\_\_

ABSTAIN: \_\_\_\_\_

APPROVED THIS 21<sup>st</sup> day of November, 2024.

\_\_\_\_\_

Michael J. Reid, Jr.  
Village President

ATTEST:

\_\_\_\_\_  
Karen Stuehler  
Village Clerk



November 13, 2024

Mr. Jay Hedges (Via Email)  
Village Manager  
Village of Hampshire  
234 S. State Street  
Hampshire, IL 60140-0457

**Re: Hampshire Grove Business Park 2  
Ryan Drive and Old Dominion  
Bond Reduction Request and Acceptance of Public Improvements  
Village of Hampshire**

Mr. Hedges:

We have reviewed the bond reduction requests for Hampshire Grove Business Park 2 for public improvements on Ryan Drive and the Old Dominion project as documented by the attached spreadsheets submitted by the Developer's Engineer. In addition, we have completed punch list inspections in coordination with Public Works to verify completion of the public improvements. See attached Certificate of Acceptance.

The Developer is requesting release of their construction surety bonds and will post maintenance bonds for the required one year maintenance period following acceptance of the improvements. The value of the maintenance bonds will be 10% of the cost of the completed improvements. The required value for the Ryan Drive Maintenance Bond is **\$160,587** and the required value for the Old Dominion Maintenance Bond is **\$64,903**.

We recommend Village acceptance of the public improvements for Hampshire Grove Business Park 2. In addition, we recommend the release of Bond No. 107733058 and Bond No. 107733053 following submittal of the required maintenance bonds for the project.

If you have any questions or need additional information, please contact our office.

Respectfully Submitted,  
ENGINEERING ENTERPRISES, INC.

A handwritten signature in blue ink, appearing to read 'Timothy N. Paulson', written over a white background.

Timothy N. Paulson, P.E., CFM  
Senior Project Manager

TNP/pgw2

Enclosures

pc: Karen Stuehler, Village Clerk (via e-mail)  
Lori Lyons, Finance Director (via e-mail)  
Mo Kahn, Assistant Village Manager (via e-mail)  
James Vasselli, Village Attorney (via e-mail)  
Kevin McDonough, Northern Builders (via e-mail)  
Daniel Stevens, Spaceco, Inc..

G:\Public\Hampshire\2022\HA2208 Jafari Property-Northern Builders (Hampshire Grove, Lot 2)\Construction\Acceptance\RyanDriveLOCReduction&Acceptance01.doc



FINAL  
ENGINEER'S OPINION OF  
PROBABLE CONSTRUCTION COST  
FOR  
BONDING PURPOSES

PROJECT: **RYAN DRIVE EXTENSION-PHASE 2 AT  
HAMPSHIRE GROVE BUSINESS CENTER**

LOCATION: HAMPSHIRE, ILLINOIS

PROJECT NO.: 10366.02

CLIENT : **NORTHERN BUILDERS, INC.**  
5060 RIVER ROAD  
SCHILLER PARK, IL 60176

DATE PREPARED: 10/14/2024  
LAST REVISED:

PREPARED BY: GD  
CHECKED BY: DCS

GROUP MANAGER:

  
(HAND WRITTEN INITIALS)



*THE PRICES USED IN THIS LIST ARE BASED ON THE AVERAGE PRICES FROM CONTRACTOR'S  
BID PRICES REVIEWED WITHIN THE PAST YEAR BY SPACECO, INC. FOR SIMILAR PROJECTS  
AND/OR AVAILABLE MATERIAL & LABOR COST DATA. SOME UNIT PRICES HAVE BEEN ADJUSTED  
TO ALLOW FOR SPECIAL CONDITIONS. THESE UNIT PRICES DO NOT INCLUDE ENGINEERING FEES.*

**CONSULTING ENGINEERS \* SITE DEVELOPMENT ENGINEERS \* LAND SURVEYORS**

Engineer's Opinion of Probable Construction Cost

ITEM	QNTY	UNIT	UNIT		COMPLETED QUANTITY	COMPLETED AMOUNT	REMAINING QUANTITY	REMAINING AMOUNT
			PRICE	AMOUNT				
<b>A. Soil Erosion Sediment Control</b>								
1. Stormwater Inlet Protection	12	EACH	\$200.00	\$2,400	12	\$2,400.00		\$0.00
2. Silt Fence	230	L.F.	\$2.00	\$460	230	\$460.00		\$0.00
3. Stabilized Entrance	1	EACH	\$5,000.00	\$5,000	1	\$5,000.00		\$0.00
5. Concrete Washout	1	EACH	\$2,000.00	\$2,000	1	\$2,000.00		\$0.00
6. Erosion Control Blanket	5,223	S.Y.	\$5.00	\$26,115	5223	\$26,115.00		\$0.00
7. Permanent Seeding	8,335	S.Y.	\$2.50	\$20,838	8335	\$20,837.50		\$0.00
8. Temporary Seeding	0.63	ACRE	\$5,000.00	\$3,150	0.63	\$3,150.00		\$0.00
A. Soil Erosion Sediment Control			Sub-Total =	\$59,963		\$59,962.50		\$0.00
<b>B. Earthwork Improvements</b>								
1. Topsoil Strip to Respread	2,600	C.Y.	\$10.00	\$26,000	2600	\$26,000.00		\$0.00
2. Topsoil Strip to Clay Borrow	2,600	C.Y.	\$5.00	\$13,000	2600	\$13,000.00		\$0.00
3. Clay Cut to Site Fill	1	L.S.	\$200,000.00	\$200,000	1	\$200,000.00		\$0.00
4. Fine Grading of Pavement Areas	4,100	S.Y.	\$5.75	\$23,575	4100	\$23,575.00		\$0.00
5. Backfill Curbs	2,170	L.F.	\$3.00	\$6,510	2170	\$6,510.00		\$0.00
6. Retaining Wall With Handrail	2,900	S.F.F.	\$45.00	\$130,500	2900	\$130,500.00		\$0.00
B. Earthwork Improvements			Sub-Total =	\$399,585		\$399,585.00		\$0.00
<b>C. Drainage Improvements</b>								
1. 12" Storm Sewer, RCP CL IV	271	L.F.	\$30.00	\$8,130.00	271	\$8,130.00		\$0.00
2. 15" Storm Sewer, RCP CL IV	579	L.F.	\$35.00	\$20,265.00	579	\$20,265.00		\$0.00
3. 24" DIA. Inlet	5	EACH	\$1,750.00	\$8,750.00	5	\$8,750.00		\$0.00
4. 48" DIA. Catch Basin	5	EACH	\$3,000.00	\$15,000.00	5	\$15,000.00		\$0.00
5. 48" DIA. Manhole	6	EACH	\$2,750.00	\$16,500.00	6	\$16,500.00		\$0.00
6. Trench Backfill	265	L.F.	\$45.00	\$11,925.00	265	\$11,925.00		\$0.00
C. Drainage Improvements			Sub-Total =	\$80,570		\$80,570.00		\$0.00
<b>D. Watermain Improvements</b>								
1. 6" Watermain, DIP CL 52	15	L.F.	\$65.00	\$975	15	\$975.00		\$0.00
2. 10" Watermain, DIP CL 52	83	L.F.	\$75.00	\$6,225.00	83	\$6,225.00		\$0.00
3. 12" Watermain, DIP CL 52	936	L.F.	\$82.50	\$77,220.00	936	\$77,220.00		\$0.00
4. 10" Valve in Vault	1	EACH	\$7,000.00	\$7,000.00	1	\$7,000.00		\$0.00
5. 12" Valve in Vault	3	EACH	\$8,000.00	\$24,000.00	3	\$24,000.00		\$0.00
6. Fire Hydrant	3	EACH	\$9,000.00	\$27,000.00	3	\$27,000.00		\$0.00
7. Trench Backfill	91	L.F.	\$45.00	\$4,095.00	91	\$4,095.00		\$0.00
8. Test and Chlorinate Watermain	1	L.S.	\$5,000.00	\$5,000.00	1	\$5,000.00		\$0.00
D. Watermain Improvements			Sub-Total =	\$151,515		\$151,515.00		\$0.00
<b>E. Sanitary Sewer Improvements</b>								
1. 8" Sanitary Sewer, PVC SDR 18	70	L.F.	\$60.00	\$4,200.00	70	\$4,200.00		\$0.00
2. 4" PVC Forcemain DR18	900	L.F.	\$75.00	\$67,500.00	900	\$67,500.00		\$0.00
3. Sanitary Manhole, 48" DIA.	2	EACH	\$7,000.00	\$14,000.00	2	\$14,000.00		\$0.00
4. Trench Backfill	216	L.F.	\$45.00	\$9,720.00	216	\$9,720.00		\$0.00
5. Test Sanitary Systems as Required	1	L.S.	\$5,000.00	\$5,000.00	1	\$5,000.00		\$0.00
6. Sanitary Sewer Lift Station Complete	1	L.S.	\$385,000.00	\$385,000.00	1	\$385,000.00		\$0.00
E. Sanitary Sewer Improvements			Sub-Total =	\$485,420		\$485,420.00		\$0.00

**Engineer's Opinion of Probable Construction Cost**

ITEM	QNTY	UNIT	UNIT		COMPLETED QUANTITY	COMPLETED AMOUNT	REMAINING QUANTITY	REMAINING AMOUNT
			PRICE	AMOUNT				
<b>F. Roadway Improvements</b>								
1. Curb & Gutter (B6.12)	2,170	L.F.	\$21.25	\$46,112.50	2170	\$46,112.50		\$0.00
2. Concrete Sidewalk (5" P.C.C/4" Agg. Base, CA-6)	3,580	S.F.	\$7.50	\$26,850.00	3580	\$26,850.00		\$0.00
3. ADA Ramps	120	S.F.	\$20.00	\$2,400.00	120	\$2,400.00		\$0.00
<u>Asphalt Pavement</u>								
4. 1.5" HMA Surface Course, N70	3,860	S.Y.	\$9.00	\$34,740.00	3860	\$34,740.00		\$0.00
5. 5.5" HMA Binder Course IL 19.0, N70	3,860	S.Y.	\$27.00	\$104,220.00	3860	\$104,220.00		\$0.00
6. 12" Aggregate Base Course, CA-6, Type A	3,860	S.Y.	\$16.00	\$61,760.00	3860	\$61,760.00		\$0.00
7. 1.5" HMA Surface Course, Mix "C", N50	245	S.Y.	\$9.00	\$2,205.00	245	\$2,205.00		\$0.00
8. 2.5" HMA Binder Course, IL 19.0, N50	245	S.Y.	\$18.00	\$4,410.00	245	\$4,410.00		\$0.00
9. 12" Aggregate Base Course, Type B	245	S.Y.	\$15.00	\$3,675.00	245	\$3,675.00		\$0.00
<u>Concrete Pavement</u>								
8. 8" PCC Pavement reinforced with 6" x 6" wire mesh	285	S.Y.	\$70.00	\$19,950.00	285	\$19,950.00		\$0.00
9. 4" Aggregate Base Course, Type B	285	S.Y.	\$7.00	\$1,995.00	285	\$1,995.00		\$0.00
<u>Miscellaneous</u>								
10. Street Lighting	5	EACH	\$17,000.00	\$85,000.00	5	\$85,000.00		\$0.00
11. Stop Sign	1	EACH	\$1,000.00	\$1,000.00	1	\$1,000.00		\$0.00
12. Stop Bar, 24"	1	EACH	\$2,500.00	\$2,500.00	1	\$2,500.00		\$0.00
13. Landscaping	1	LS	\$32,000.00	\$32,000.00	1	\$32,000.00		\$0.00
F. Roadway Improvements				Sub-Total =	\$428,818	\$428,817.50		\$0.00
				<b>SUB-TOTAL =</b>	<b>\$1,605,870</b>	<b>\$1,605,870.00</b>		<b>\$0.00</b>
				10% CONTINGENCY =	\$160,587	\$160,587.00		\$0.00
				<b>TOTAL =</b>	<b>\$1,766,457</b>	<b>\$1,766,457.00</b>		<b>\$0.00</b>

**NOTES:**

- This estimate is prepared based on "Site Improvement Plans for Ryan Drive Extension-Phase 2 at Hampshire Grove Business Park" Dated 10/07/22, last revised 11/09/22.
- This estimate is prepared as a guide only. SPACECO makes no warranty that actual costs will not vary from the amounts indicated, and assumes no liability for such variance.
- Ryan Drive Improvements included for Sta. 50+00 to Sta. 60+00 (1000 LF)
- This estimate DOES NOT include:
  - PERMIT FEES
  - REVIEW FEES
  - UNSUITABLE UNDERCUT REMOVAL
- This estimate DOES NOT include:
  - Maintenance costs for: EROSION CONTROL



FINAL  
ENGINEER'S OPINION OF  
PROBABLE CONSTRUCTION COST  
FOR  
EROSION CONTROL, STORMWATER MANAGEMENT FACILITIES,  
AND PUBLIC IMPROVEMENTS  
BONDING PURPOSES

PROJECT: **OLD DOMINION FREIGHT LINE**  
**HAMPSHIRE GROVE BUSINESS CENTER**

LOCATION: HAMPSHIRE, ILLINOIS

PROJECT NO.: 10366.04

CLIENT : **OLD DOMINION FREIGHT LINE, INC.**  
500 OLD DOMINION WAY  
THOMASVILLE, NC 27360

DATE PREPARED: 10/9/2024

LAST REVISED:

PREPARED BY: GD  
CHECKED BY: JB / DCS

GROUP MANAGER:

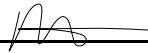
  
(HAND WRITTEN INITIALS)



*THE PRICES USED IN THIS LIST ARE BASED ON THE AVERAGE PRICES FROM CONTRACTOR'S  
BID PRICES REVIEWED WITHIN THE PAST YEAR BY SPACECO, INC. FOR SIMILAR PROJECTS  
AND/OR AVAILABLE MATERIAL & LABOR COST DATA. SOME UNIT PRICES HAVE BEEN ADJUSTED  
TO ALLOW FOR SPECIAL CONDITIONS. THESE UNIT PRICES DO NOT INCLUDE ENGINEERING FEES.*





Hampshire

CERTIFICATE FOR ACCEPTANCE OF PUBLIC IMPROVEMENTS

Subdivision: Hampshire Grove Business Park 2

- Improvements: [X] Streets, [X] Sidewalks, [X] Water Main, [X] Sanitary Sewer Main, [X] Street Lights, [X] Storm Sewer System, [ ] Retention/Detention Basin, [ ] Other Drainage Facilities, [X] Parkway Trees

Other Improvements:

1. The above-described improvements constitute public improvements constructed or installed in or upon the streets or thoroughfares or otherwise in said subdivision, as described on the Final Plat of Subdivision, recorded as Doc. No. 2023K024267.

2. All of said improvements have been inspected by Engineering Enterprises, Inc. and continue to meet the standards set forth in the Village of Hampshire Subdivision Code and/or any applicable annexation agreement for the development, and may be accepted by the Corporate Authorities at this time.

November 13, 2024 DATE

ENGINEERING ENTERPRISES, INC. Village Engineer By: [Signature]

Note: Upon completion of all required improvements and acceptance thereof by the Village, any cash or letter of credit shall be reduced to an amount equal to ten (10%) percent of the estimated construction costs, which sum shall be retained for a period of one year following acceptance and may be used by the Village to make any necessary repairs arising out of the defects in work or materials. 7-2-4(D)(3).

BILL OF SALE

Seller, HAMPSHIRE GROVE 62 LLC, an Illinois limited liability company, having its principal place of business at 5060 River Road, Schiller Park, Illinois 60176, in consideration of Ten & No/100 Dollars and other good and valuable consideration, the sufficiency of which is hereby acknowledged, does hereby sell, assign, transfer and set over to Buyer, VILLAGE OF HAMPSHIRE, an Illinois Municipality, of Hampshire, Illinois, Kane County, the following described personal property included in the Dedication of Ryan Drive as shown on that certain Plat of Subdivision for Hampshire Grove Business Park 2 recorded on July 19, 2023 as Document No. 2023K024267 to-wit:

The sanitary sewer system, including, but not limited to, sanitary sewer lines, laterals, manholes, frames, grates, and all structures appurtenant thereto;

The storm sewer system, including, but not limited to, storm sewer lines, laterals, catch basins, inlets, manholes, frames, grates, and all structures appurtenant thereto;

That certain street known as Ryan Drive, including, but not limited to, gutters, pavement, and all structures appurtenant thereto;

All public sidewalks, parkway trees and public landscaping improvement;

The street light system, including, but not limited to, all structures and wiring systems appurtenant thereto;

The above being those certain Public Improvements for the Hampshire Grove Business Park developed by the Seller in the Village of Hampshire.

Seller hereby represents and warrants to Buyer that Seller is the absolute owner of said property, that said property is free and clear of all liens, charges and encumbrances, and that Seller has full right, power and authority to sell said personal property and to make this bill of sale.

IN WITNESS WHEREOF, Seller has caused this bill of sale to be signed and sealed in its name by its manager thereunto duly authorized this 7<sup>th</sup> day of November, 2024.

HAMPSHIRE GROVE 62 LLC

By: 

Name: Thomas R. Kenrich

Its: Chief Financial Officer and Authorized Agent

STATE OF ILLINOIS     )  
  )  
COUNTY OF COOK        )

I, Julie A. Stritzel a Notary Public in and for said County, in the State aforesaid, DO HEREBY CERTIFY that Thomas R. Kenrich, the Chief Financial Officer and Authorized Agent of Hampshire Grove 62 LLC, an Illinois limited liability company, is personally known to me to be the same person whose name is subscribed to the foregoing instrument, appeared before me this day in person and severally acknowledged that as such Chief Financial Officer and Authorized Agent, he signed and delivered the said instrument, pursuant to authority given by the Chief Financial Officer and Authorized Agent of said company as his free and voluntary act and as the free and voluntary act and deed of said company, for the uses and purposes therein set forth.

GIVEN under my hand and official seal this 7<sup>th</sup> day of November, 2024.



Notary Public *J*



# VILLAGE OF HAMPSHIRE

## RESOLUTION NO. 24-\_\_\_\_\_

### **A RESOLUTION ACCEPTING THE PUBLIC IMPROVEMENTS TO RYAN DRIVE AND RELEASING BONDS NO. 107733053 AND 107733058 FOR THE VILLAGE OF HAMPSHIRE, KANE AND MCHENRY COUNTIES, ILLINOIS** *(Hampshire Grove Business Park 2 Development Project)*

**WHEREAS**, the Village of Hampshire, Illinois (the “Village”) is a duly organized and validly existing non-home rule municipality organized and operating under the Illinois Municipal Code (65 ILCS 5/1-1-1, *et seq.*); and

**WHEREAS**, the President of the Village (the “President”) and the Board of Trustees of the Village (the “Village Board” and with the President, the “Corporate Authorities”) are committed to furthering the growth of the Village, enabling the Village to control development in the area and promoting public health, safety, comfort, morals and welfare; and

**WHEREAS**, pursuant to Section 7-5-1 of the Municipal Code of Hampshire of 1985 (the “Village Code”) the Village may accept streets and improvements by resolution after the Village engineer files a certificate with the Village clerk (the “Village Clerk”) certifying that all improvements required to be constructed or installed have been fully completed and constructed or installed; and

**WHEREAS**, in connection with a subdivision known as Hampshire Grove Business Park 2 (the “Project”), HAMPSHIRE GROVE 62 LLC (the “Developer”), undertook a number of public improvements as set forth in the final plat of subdivision for the Project (the “Final Plat”), which improvements include, without limitation, sidewalks, streets, landscaping, a water main, the sanitary sewer system, and the storm sewer system (the “Improvements”); and

**WHEREAS**, the Developer has requested that the Village accept the Improvements; and

**WHEREAS**, Engineering Enterprises, Inc. (the “Village Engineer”) has certified that the Improvements, as set forth in the Final Plat, have been satisfactorily completed, constructed or

## VILLAGE OF HAMPSHIRE

installed in accordance with applicable codes, engineering plans, agreements and ordinances as further described in the certificate for acceptance of public improvements (the “Certificate”), attached hereto and incorporated herein as Exhibit A; and

**WHEREAS**, the Developer has tendered to the Village a bill of sale (the “Bill of Sale”) granting, selling, transferring and delivering to the Village ownership of the Improvements; and

**WHEREAS**, it is in the best interest of the Village to accept the Improvements subject to a one (1) year maintenance period (the “Maintenance Period”) covering a performance guarantee of the Developer; and

**WHEREAS**, in accordance with Section 7-2-4(D)(3) of the Village Code, the Village will retain bonds during the Maintenance Period to secure the future maintenance of the Improvements, in an amount equal to ten percent (10%) of the estimated construction cost of the Improvements (the “Maintenance Bonds”);

**NOW, THEREFORE, BE IT RESOLVED** BY THE PRESIDENT AND BOARD OF TRUSTEES OF THE VILLAGE OF HAMPSHIRE, KANE AND MCHENRY COUNTIES, ILLINOIS, AS FOLLOWS:

**SECTION 1.** The Corporate Authorities hereby find that all of the recitals as contained in the preambles to this Resolution are full, true and correct and hereby incorporate and make them part of this Resolution.

**SECTION 2.** The Village hereby accepts the Improvements, subject to the Maintenance Period, which shall commence upon formal acceptance of Improvements by the Village.

**SECTION 3.** The Developer shall provide Maintenance Bonds for the Ryan Drive improvements in the amount of one hundred and sixty thousand, five hundred and eighty-seven dollars and NO/100 cents (\$160,587), and for the Old Dominion improvements in the amount of

## VILLAGE OF HAMPSHIRE

sixty-four thousand, nine hundred and three dollars and NO/100 cents (\$64,903), to cover repairs and maintenance of the Improvements during the Maintenance Period. The Developer currently has Bond No. 107733053 and Bond No. 107733058 which, together, are sufficient to cover the total estimated cost of the Improvements (the “Original Bonds”). Upon the Village Board’s approval of the acceptance and receipt of the executed Bill of Sale and the updated Original Bonds amount (which reflects the value of the Maintenance Bonds), the Village shall release the Original Bonds. The Maintenance Bonds shall remain in full force and effect throughout the term of the Maintenance Period.

**SECTION 4.** That all past, present and future acts and doings of the officials of the Village that are in conformity with the purpose and intent of this Resolution are hereby, in all respects, ratified, approved, authorized and confirmed.

**SECTION 5.** That the provisions of this Resolution are hereby declared to be severable and should any provision of this Resolution be determined to be in conflict with any law, statute or regulation by a court of competent jurisdiction, said provision shall be excluded and deemed inoperative, unenforceable and as though not provided for herein and all other provisions shall remain unaffected, unimpaired, valid and in full force and effect.

**SECTION 6.** All code provisions, ordinances, resolutions, rules and orders, or parts thereof, in conflict herewith are, to the extent of such conflict, hereby superseded.

**SECTION 7.** If required by law, a full, true and complete copy of this Resolution shall be published in book or pamphlet form or in a newspaper published and of general circulation within the Village.

**SECTION 8.** This Resolution shall be effective and in full force immediately upon passage and approval as provided by law.

**VILLAGE OF HAMPSHIRE**

ADOPTED THIS \_\_ DAY OF \_\_\_\_\_, 2024.

AYES: \_\_\_\_\_

NAYS: \_\_\_\_\_

ABSENT: \_\_\_\_\_

ABSTAIN: \_\_\_\_\_

ADOPTED THIS \_\_ DAY OF \_\_\_\_\_, 2024.

\_\_\_\_\_  
Michael J. Reid, Jr., Village President

ATTEST:

\_\_\_\_\_  
Karen L. Stuehler, Village Clerk

**VILLAGE OF HAMPSHIRE**

STATE OF ILLINOIS     )  
  ) SS  
COUNTY OF KANE        )

**CLERK’S CERTIFICATE**  
**(RESOLUTION)**

I, Karen L. Stuehler, certify that I am the duly appointed and acting Clerk of the Village of Hampshire, Kane and McHenry Counties, Illinois, and I do hereby certify that I am currently the keeper of its books and records and that the attached hereto is a true and correct copy of a Resolution titled:

**A RESOLUTION ACCEPTING THE PUBLIC IMPROVEMENTS TO RYAN DRIVE AND RELEASING BONDS NO. 107733053 AND 107733058 FOR THE VILLAGE OF HAMPSHIRE, KANE AND MCHENRY COUNTIES, ILLINOIS**  
***(Hampshire Grove Business Park 2 Development Project)***

I certify that on \_\_\_\_\_, 2024, the Board of Trustees of Hampshire (or the Corporate Authorities, if required by law) passed and adopted Resolution No. \_\_\_\_\_, which was approved by the Village President on the \_\_\_\_\_ day of \_\_\_\_\_, 2024.

I do further certify, in my official capacity, that a quorum of said Board of Trustees was present at the meeting and that the meeting was held in compliance with all requirements of the Open Meetings Act (5 ILCS 120/1, *et seq.*).

A copy of such Resolution was available for public inspection upon request in the office of the Village Clerk.

DATED at Hampshire, Illinois, this \_\_\_\_\_ day of \_\_\_\_\_, 2024.

\_\_\_\_\_  
Karen L. Stuehler, Village Clerk  
Village of Hampshire

(Seal)





EMBRACE OPPORTUNITY

HONOR TRADITION

# HAMPSHIRE POLICE DEPARTMENT MONTHLY REPORT

November 2024

Chief Doug Pann

# HAMPSHIRE POLICE DEPARTMENT OCTOBER SCORECARD



## Hampshire Police Department Scorecard

Oct-24

### OFFENSES

	Previous Month	Current Month	% Change	YTD	YTD '23	YTD '22
Group A Offenses	N/A	N/A	N/A	35	65	60
All Dispatched Calls for Service	306	309	1.0%	2858	2728	2200
Burglary	0	0	0.0%	1	1	4
Burglary to Motor Vehicle and Theft from Motor Vehicle	0	2	200.0%	2	11	1
Auto Theft	0	0	0.0%	4	2	2
Theft	2	1	-50.0%	14	23	26
Domestic Violence Cases	3	2	-33.3%	27	8	10
Mental Health Calls for Service	N/A	N/A	N/A	24	25	N/A
Alarm Responses	9	13	44.4%	120	100	130
Assists to Neighboring Communities / KCSO	28	31	10.7%	242	181	219

### ACTIVITY

	Previous Month	Current Month	% Change	YTD
# Traffic Stops	111	98	-11.7%	1177
# Traffic Tickets	146	56	-61.6%	485
# Traffic Warnings	55	66	20.0%	629
# Parking Tickets	52	85	63.5%	336

# YEAR TO DATE CALLS FOR SERVICE - 5 YEAR COMPARISON

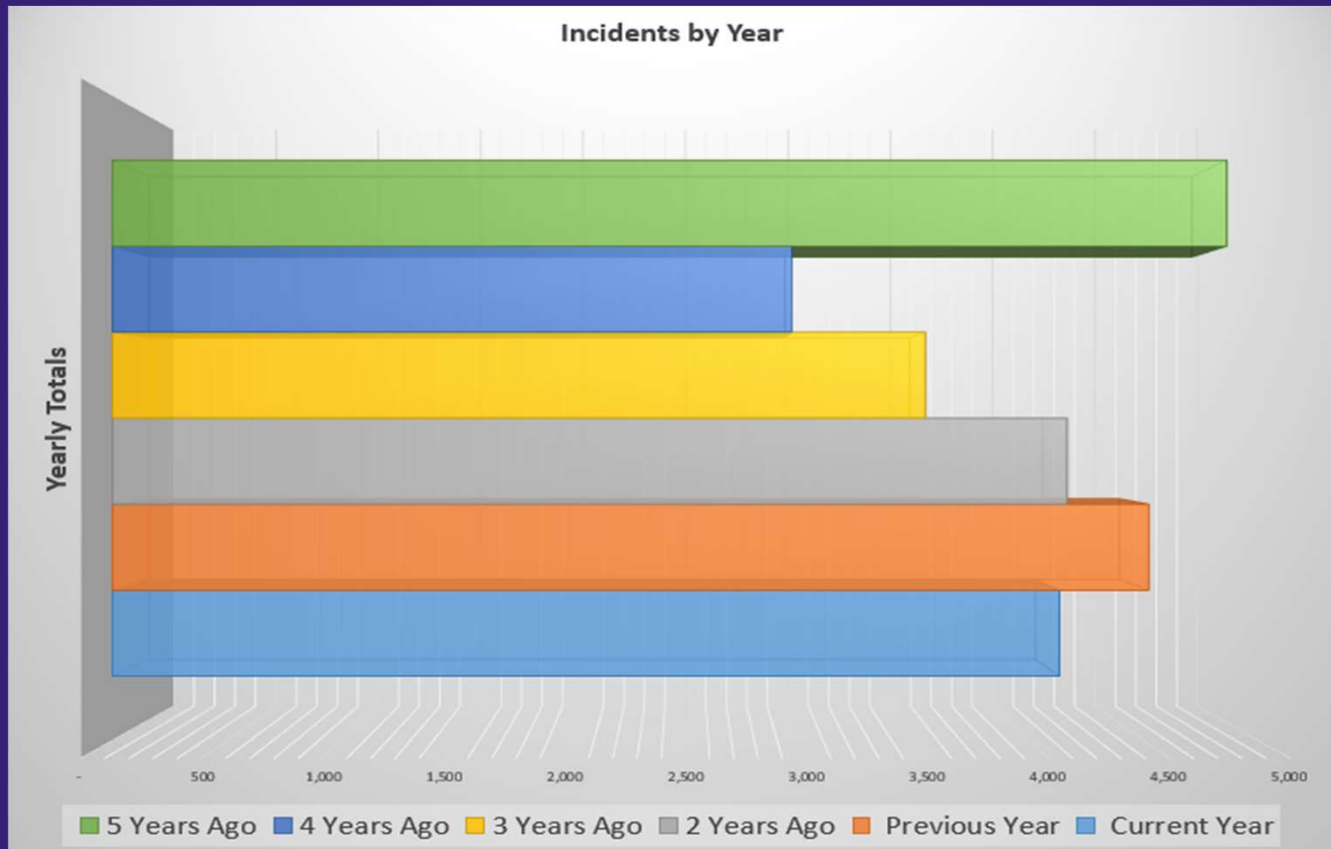

# OFFENSE TRENDS COMPARISON 2023-2024



Data Not Available Due or Transition to New RMS

# CURRENT PROJECTS



Project	Start Date	Status
Install In-car printers and transition to digital ticketing	11/01/2022	Waiting for Tyler to make final changes
Revise and Update Village Emergency Operations Plan with HFPD	02/01/2024	Formed Committee with Fire Department
Develop and Implement Chaplain Program	03/01/2024	Held Kick-Off Meeting - Chaplains to be introduced next month
Develop Officer Wellness Program / Peer-to-Peer Support	03/01/2024	Revising draft policy / Training Volunteers
ILEAP Accreditation	07/01/2024	Grant Received Software Procured Lieutenant Neblock Working Through Process

# GOALS ACCOMPLISHED



Project	Start Date	Status
New Squad Cars Deployed		Two new squads deployed
Lateral Transfer Officer Munoz Sworn-in		Successfully Completed Training and Deployed
ECC Intern		ECC Criminal Justice Intern On-Board and Completing Semester

# NEW SQUAD CAR DESIGN



## **Village of Hampshire Street Department**

Monthly Report: October 2024

**Large Group Gatherings** - Homecoming Parade road closures, Trunk-or-Treat  
Provided a vehicle and road closures and Outdoor Market barricades and  
cones.

**Sign Installation** - Door To Door Solicitors Must Display Village Issued Photo ID

**Sweeper** - Swept entire Village and continuing with Fall Leaves

**Mowing** - Last time mowing Right of Ways and SSA's

**Plow Trucks** - Continuing maintenance on Trucks and Equipment

**Plow Trucks** - Taking to safety lane

**Street Light Repair** - 1740 Cameron dr, 2620 Hennig rd and 1201 Old Oak ct

**Pavement Striping** - Melms rd, Higgins rd and Kelley rd from Hamony east

**Bike Rack** - Installed bike rack downtown donated by the Girl Scouts

**Storm Sewer Repair** -

555 Prairie st (ran new pipe from inlet to tile)

201 E. Jefferson ave (infiltration around pipe and adjustment rings)

227 Johnson ave (infiltration around pipe)

804 Karen dr (frame off-set from basin)

### **Utility Locates**

332 Normal

28 Emergency

### **Asphalt Usage**

25.36 tons for patches

### **Work Performed**

Vehicle and Equipment Maintenance

Pothole Patching

Sidewalk Grinding

Other Miscellaneous Projects



Village of Hampshire  
 Budget Versus Actual Report Overview  
 Five Months Ended September 30, 2024

General Fund						% of Budget
5 MONTHS ENDED				2024-2025		
YTD BUDGET	YTD ACTUAL	DELTA \$	DELTA %	TOT BUDGET		
Revenue	3,816,879	3,937,888	121,009	3%	8,886,578	44%
Expenditures/Expense	3,892,013	3,484,563	(407,450)	-10%	9,340,825	37%
YTD Surplus/(Deficit)	(75,134)	453,325	528,459		(454,247)	
Special Revenue Funds						
Revenue	358,124	685,465	327,341	91%	780,069	88%
Expenditures/Expense	282,415	231,567	(50,848)	-18%	677,794	34%
YTD Surplus/(Deficit)	75,709	453,898	378,189		102,275	
Capital Project Funds						
Revenue	5,112,438	245,781	(4,866,657)	-95%	12,269,848	2%
Expenditures/Expense	5,168,987	184,175	(4,984,812)	-96%	12,405,569	1%
YTD Surplus/(Deficit)	(56,549)	61,606	118,155		(135,721)	
Enterprise Funds						
Revenue	2,555,719	1,812,011	(743,708)	-29%	6,133,724	30%
Expenditures/Expense	2,439,583	1,346,710	(1,092,873)	-45%	5,854,998	23%
YTD Surplus/(Deficit)	116,136	465,301	349,165		278,726	
Total Village						
Revenue	11,843,160	6,681,145	(5,162,015)	-44%	28,070,219	24%
Expenditures/Expense	11,782,998	5,247,015	(6,535,983)	-55%	28,279,186	19%
YTD Surplus/(Deficit)	60,162	1,434,130	1,373,968		(208,967)	



Agency Funds						% of Budget
5 MONTHS ENDED				2024-2025		
YTD BUDGET	YTD ACTUAL	DELTA \$	DELTA %	TOT BUDGET		
Revenue	603,924	1,204,890	600,966	100%	1,215,349	99%
Expenditures/Expense	516,438	227,225	(289,213)	-56%	1,239,451	18%
YTD Surplus/(Deficit)	87,486	977,665	890,179		(24,102)	

Pension Trust Fund						% of Budget
5 MONTHS ENDED				2024-2025		
YTD BUDGET	YTD ACTUAL	DELTA \$	DELTA %	TOT BUDGET		
Revenue	384,465	426,674	42,209	11%	922,717	46%
Expenditures/Expense	235,851	85,206	(150,645)	-64%	566,044	15%
YTD Surplus/(Deficit)	148,614	341,468	192,854		356,673	



Village of Hampshire  
 Budget Versus Actual Report - General Fund Subfunds  
 Five Months Ended September 30, 2024

	School Impact Fees (60)					Library Impact Fees (61)				
	5 MONTHS ENDED		2024-2025			5 MONTHS ENDED		2024-2025		
	YTD BUDGET	YTD ACTUAL	DELTA \$	DELTA %	TOT BUDGET	YTD BUDGET	YTD ACTUAL	DELTA \$	DELTA %	TOT BUDGET
<b>REVENUE</b>										
Investment Income	208	127	(81)	-39%	500	333	322	(11)	-3%	800
Licenses, Fines, Permits, Fees	231,347	309,373	78,026	34%	555,233	18,089	22,312	4,223	23%	43,412
<b>TOTAL REVENUE</b>	<b>231,555</b>	<b>309,500</b>	<b>77,945</b>	<b>34%</b>	<b>555,733</b>	<b>18,422</b>	<b>22,634</b>	<b>4,212</b>	<b>23%</b>	<b>44,212</b>
<b>EXPENSE</b>										
Other Expenses	231,555	323,932	92,377	40%	555,733	18,422	10,012	(8,410)	-46%	44,212
<b>TOTAL EXPENSE</b>	<b>231,555</b>	<b>323,932</b>	<b>92,377</b>	<b>40%</b>	<b>555,733</b>	<b>18,422</b>	<b>10,012</b>	<b>(8,410)</b>	<b>-46%</b>	<b>44,212</b>
<b>YEAR-TO-DATE SURPLUS/(DEFICIT)</b>	<b>-</b>	<b>(14,432)</b>	<b>(14,432)</b>	<b>100%</b>	<b>-</b>	<b>-</b>	<b>12,622</b>	<b>12,622</b>	<b>100%</b>	<b>-</b>

	Parks Impact Fees (62)					Fire Impact Fees (63)				
	5 MONTHS ENDED		2024-2025			5 MONTHS ENDED		2024-2025		
	YTD BUDGET	YTD ACTUAL	DELTA \$	DELTA %	TOT BUDGET	YTD BUDGET	YTD ACTUAL	DELTA \$	DELTA %	TOT BUDGET
<b>REVENUE</b>										
Investment Income	17	16	(1)	-6%	40	42	43	1	2%	100
Licenses, Fines, Permits, Fees	11,975	28,126	16,151	135%	28,740	67,401	86,677	19,276	29%	161,762
<b>TOTAL REVENUE</b>	<b>11,992</b>	<b>28,142</b>	<b>16,150</b>	<b>135%</b>	<b>28,780</b>	<b>67,443</b>	<b>86,720</b>	<b>19,277</b>	<b>29%</b>	<b>161,862</b>
<b>EXPENSE</b>										
Other Expenses	11,992	28,618	16,626	139%	28,780	67,443	66,170	(1,273)	-2%	161,862
<b>TOTAL EXPENSE</b>	<b>11,992</b>	<b>28,618</b>	<b>16,626</b>	<b>139%</b>	<b>28,780</b>	<b>67,443</b>	<b>66,170</b>	<b>(1,273)</b>	<b>-2%</b>	<b>161,862</b>
<b>YEAR-TO-DATE SURPLUS/(DEFICIT)</b>	<b>-</b>	<b>(476)</b>	<b>(476)</b>	<b>100%</b>	<b>-</b>	<b>-</b>	<b>20,550</b>	<b>20,550</b>	<b>100%</b>	<b>-</b>

	Cemetery Impact Fees (66)					Township Impact Fees (67)				
	5 MONTHS ENDED		2024-2025			5 MONTHS ENDED		2024-2025		
	YTD BUDGET	YTD ACTUAL	DELTA \$	DELTA %	TOT BUDGET	YTD BUDGET	YTD ACTUAL	DELTA \$	DELTA %	TOT BUDGET
<b>REVENUE</b>										
Investment Income	15	25	10	67%	35	3	3	-	0%	7
Licenses, Fines, Permits, Fees	3,645	4,250	605	17%	8,750	7,310	9,775	2,465	34%	17,540
<b>TOTAL REVENUE</b>	<b>3,660</b>	<b>4,275</b>	<b>615</b>	<b>17%</b>	<b>8,785</b>	<b>7,313</b>	<b>9,778</b>	<b>2,465</b>	<b>34%</b>	<b>17,550</b>
<b>EXPENSE</b>										
Other Expenses	3,660	-	(3,660)	-100%	8,785	7,313	10,235	2,922	40%	17,550
<b>TOTAL EXPENSE</b>	<b>3,660</b>	<b>-</b>	<b>(3,660)</b>	<b>-100%</b>	<b>8,785</b>	<b>7,313</b>	<b>10,235</b>	<b>2,922</b>	<b>40%</b>	<b>17,550</b>
<b>YEAR-TO-DATE SURPLUS/(DEFICIT)</b>	<b>-</b>	<b>4,275</b>	<b>4,275</b>	<b>100%</b>	<b>-</b>	<b>-</b>	<b>(457)</b>	<b>(457)</b>	<b>100%</b>	<b>-</b>

	Total General Fund Subfunds				
	5 MONTHS ENDED		2024-2025		
	YTD BUDGET	YTD ACTUAL	DELTA \$	DELTA %	TOT BUDGET
<b>REVENUE</b>					
Investment Income	618	536	(82)	-13%	1,482
Licenses, Fines, Permits, Fees	339,767	460,513	120,746	36%	815,440
<b>TOTAL REVENUE</b>	<b>340,385</b>	<b>461,049</b>	<b>120,664</b>	<b>35%</b>	<b>816,922</b>
<b>EXPENSE</b>					
Other Expenses	340,385	438,967	98,582	29%	816,922
<b>TOTAL EXPENSE</b>	<b>340,385</b>	<b>438,967</b>	<b>98,582</b>	<b>29%</b>	<b>816,922</b>
<b>YEAR-TO-DATE SURPLUS/(DEFICIT)</b>	<b>-</b>	<b>22,082</b>	<b>22,082</b>	<b>100%</b>	<b>-</b>

Village of Hampshire  
 Budget Versus Actual Report - Special Revenue Fund Summary  
 Five Months Ended September 30, 2024

	Tax Increment Financing (05)					Hotel/Motel Tax (07)				
	5 MONTHS ENDED		DELTA \$	DELTA %	2024-2025 TOT BUDGET	5 MONTHS ENDED		DELTA \$	DELTA %	2024-2025 TOT BUDGET
	YTD BUDGET	YTD ACTUAL				YTD BUDGET	YTD ACTUAL			
<b>REVENUE</b>										
Property Tax	104,850	252,767	147,917	141%	209,700	-	-	-	0%	-
Intergovernmental	-	-	-	0%	-	-	-	-	0%	-
Investment Income	83	500	417	502%	200	2	77	75	3750%	5
Licenses, Fines, Permits, Fees	-	-	-	0%	-	10,417	14,954	4,537	44%	25,000
Other Income	-	-	-	0%	-	-	-	-	0%	-
Transfers	-	-	-	0%	-	-	-	-	0%	-
<b>TOTAL REVENUE</b>	<b>104,933</b>	<b>253,267</b>	<b>148,334</b>	<b>141%</b>	<b>209,900</b>	<b>10,419</b>	<b>15,031</b>	<b>4,612</b>	<b>44%</b>	<b>25,005</b>
<b>EXPENSE</b>										
Contractual Services	1,042	709	(333)	-32%	2,500	7,917	19,000	11,083	140%	19,000
Commodities	-	-	-	0%	-	-	-	-	0%	-
Other Expenses	78,869	16,684	(62,185)	-79%	189,286	2,500	6,000	3,500	140%	6,000
Transfers	-	-	-	0%	-	-	-	-	0%	-
<b>TOTAL EXPENSE</b>	<b>79,911</b>	<b>17,393</b>	<b>(62,518)</b>	<b>-78%</b>	<b>191,786</b>	<b>10,417</b>	<b>25,000</b>	<b>14,583</b>	<b>140%</b>	<b>25,000</b>
<b>YEAR-TO-DATE SURPLUS/(DEFICIT)</b>	<b>25,022</b>	<b>235,874</b>	<b>210,852</b>	<b>843%</b>	<b>18,114</b>	<b>2</b>	<b>(9,969)</b>	<b>(9,971)</b>	<b>-498550%</b>	<b>5</b>

	Road and Bridge (10)					Motor Fuel Tax (15)				
	5 MONTHS ENDED		DELTA \$	DELTA %	2024-2025 TOT BUDGET	5 MONTHS ENDED		DELTA \$	DELTA %	2024-2025 TOT BUDGET
	YTD BUDGET	YTD ACTUAL				YTD BUDGET	YTD ACTUAL			
<b>REVENUE</b>										
Property Tax	66,766	120,777	54,011	81%	133,532	-	-	-	0%	-
Intergovernmental	1,922	-	(1,922)	-100%	4,612	136,498	143,845	7,347	5%	327,596
Investment Income	2	94	92	4600%	5	10,417	33,635	23,218	223%	25,000
Licenses, Fines, Permits, Fees	-	-	-	0%	-	-	-	-	0%	-
Grant Income	-	-	-	0%	-	-	67,285	67,285	100%	-
<b>TOTAL REVENUE</b>	<b>68,690</b>	<b>120,871</b>	<b>52,181</b>	<b>76%</b>	<b>138,149</b>	<b>146,915</b>	<b>244,765</b>	<b>97,850</b>	<b>67%</b>	<b>352,596</b>
<b>EXPENSE</b>										
Contractual Services	41,667	100,000	58,333	140%	100,000	22,917	-	(22,917)	-100%	55,000
Commodities	-	-	-	0%	-	104,166	75,121	(29,045)	-28%	250,000
Other Expenses	-	-	-	0%	-	-	-	-	0%	-
<b>TOTAL EXPENSE</b>	<b>41,667</b>	<b>100,000</b>	<b>58,333</b>	<b>140%</b>	<b>100,000</b>	<b>127,083</b>	<b>75,121</b>	<b>(51,962)</b>	<b>-41%</b>	<b>305,000</b>
<b>YEAR-TO-DATE SURPLUS/(DEFICIT)</b>	<b>27,023</b>	<b>20,871</b>	<b>(6,152)</b>	<b>-23%</b>	<b>38,149</b>	<b>19,832</b>	<b>169,644</b>	<b>149,812</b>	<b>755%</b>	<b>47,596</b>

	SSA #2-26 (52)					Total Special Revenue Funds				
	5 MONTHS ENDED		DELTA \$	DELTA %	2024-2025 TOT BUDGET	5 MONTHS ENDED		DELTA \$	DELTA %	2024-2025 TOT BUDGET
	YTD BUDGET	YTD ACTUAL				YTD BUDGET	YTD ACTUAL			
<b>REVENUE</b>										
Property Tax	26,959	51,175	24,216	90%	53,919	198,575	424,719	226,144	114%	397,151
Intergovernmental	-	-	-	0%	-	138,420	143,845	5,425	4%	332,208
Investment Income	208	356	148	71%	500	10,712	34,662	23,950	224%	25,710
Licenses, Fines, Permits, Fees	-	-	-	0%	-	10,417	14,954	4,537	44%	25,000
Grant Income	-	-	-	0%	-	-	67,285	67,285	100%	-
Other Income	-	-	-	0%	-	-	-	-	0%	-
Transfers	-	-	-	0%	-	-	-	-	0%	-
<b>TOTAL REVENUE</b>	<b>27,167</b>	<b>51,531</b>	<b>24,364</b>	<b>90%</b>	<b>54,419</b>	<b>358,124</b>	<b>685,465</b>	<b>327,341</b>	<b>91%</b>	<b>780,069</b>
<b>EXPENSE</b>										
Personal Services	10,034	11,454	1,420	14%	24,082	10,034	11,454	1,420	14%	24,082
Contractual Services	-	-	-	0%	-	73,543	119,709	46,166	63%	176,500
Commodities	-	-	-	0%	-	104,166	75,121	(29,045)	-28%	250,000
Other Expenses	13,303	2,599	(10,704)	-80%	31,926	94,672	25,283	(69,389)	-73%	227,212
Transfers	-	-	-	0%	-	-	-	-	0%	-
<b>TOTAL EXPENSE</b>	<b>23,337</b>	<b>14,053</b>	<b>(9,284)</b>	<b>-40%</b>	<b>56,008</b>	<b>282,415</b>	<b>231,567</b>	<b>(50,848)</b>	<b>-18%</b>	<b>677,794</b>
<b>YEAR-TO-DATE SURPLUS/(DEFICIT)</b>	<b>3,830</b>	<b>37,478</b>	<b>33,648</b>	<b>879%</b>	<b>(1,589)</b>	<b>75,709</b>	<b>453,898</b>	<b>378,189</b>	<b>500%</b>	<b>102,275</b>

Village of Hampshire  
 Budget Versus Actual Report - Capital Project Fund Summary  
 Five Months Ended September 30, 2024

	Equipment Replacement (03)					Capital Improvement (04)				
	5 MONTHS ENDED		2024-2025			5 MONTHS ENDED		2024-2025		
	YTD BUDGET	YTD ACTUAL	DELTA \$	DELTA %	TOT BUDGET	YTD BUDGET	YTD ACTUAL	DELTA \$	DELTA %	TOT BUDGET
<b>REVENUE</b>										
Investment Income	21	68	47	224%	50	-	83	83	100%	-
Licenses, Fines, Permits, Fees	-	-	-	0%	-	358,163	-	(358,163)	-100%	859,590
Grant Income	-	-	-	0%	-	-	-	-	0%	-
Debt Issuance	-	-	-	0%	-	4,500,000	-	(4,500,000)	-100%	10,800,000
Other Income	-	-	-	0%	-	-	-	-	0%	-
Transfers	-	-	-	0%	-	-	-	-	0%	-
<b>TOTAL REVENUE</b>	<b>21</b>	<b>68</b>	<b>47</b>	<b>224%</b>	<b>50</b>	<b>4,858,163</b>	<b>83</b>	<b>(4,858,080)</b>	<b>-100%</b>	<b>11,659,590</b>
<b>EXPENSE</b>										
Contractual Services	-	-	-	0%	-	-	-	-	0%	-
Other Expenses	-	-	-	0%	-	353,477	-	(353,477)	-100%	848,345
Capital Outlay	16,250	-	(16,250)	-100%	39,000	4,500,000	-	(4,500,000)	-100%	10,800,000
Transfer to General Fund	-	-	-	0%	-	-	-	-	0%	-
<b>TOTAL EXPENSE</b>	<b>16,250</b>	<b>-</b>	<b>(16,250)</b>	<b>-100%</b>	<b>39,000</b>	<b>4,853,477</b>	<b>-</b>	<b>(4,853,477)</b>	<b>-100%</b>	<b>11,648,345</b>
<b>YEAR-TO-DATE SURPLUS/(DEFICIT)</b>	<b>(16,229)</b>	<b>68</b>	<b>16,297</b>	<b>-100%</b>	<b>(38,950)</b>	<b>4,686</b>	<b>83</b>	<b>(4,603)</b>	<b>-98%</b>	<b>11,245</b>
	Public Use Fees (06)					Capital Projects/Debt Service (33)				
	5 MONTHS ENDED		2024-2025			5 MONTHS ENDED		2024-2025		
	YTD BUDGET	YTD ACTUAL	DELTA \$	DELTA %	TOT BUDGET	YTD BUDGET	YTD ACTUAL	DELTA \$	DELTA %	TOT BUDGET
<b>REVENUE</b>										
Investment Income	2,083	3,761	1,678	81%	5,000	375	1,206	831	222%	900
Licenses, Fines, Permits, Fees	119,292	98,345	(20,947)	-18%	286,300	-	-	-	0%	-
Other Income	-	-	-	0%	-	-	-	-	0%	-
Transfers	-	-	-	0%	-	-	-	-	0%	-
<b>TOTAL REVENUE</b>	<b>121,375</b>	<b>102,106</b>	<b>(19,269)</b>	<b>-16%</b>	<b>291,300</b>	<b>375</b>	<b>1,206</b>	<b>831</b>	<b>222%</b>	<b>900</b>
<b>EXPENSE</b>										
Contractual Services	-	-	-	0%	-	-	-	-	0%	-
Other Expenses	-	-	-	0%	-	12,839	-	(12,839)	-100%	30,814
Capital Outlay	-	-	-	0%	-	-	-	-	0%	-
Transfers Out	154,167	-	(154,167)	-100%	370,000	-	-	-	0%	-
<b>TOTAL EXPENSE</b>	<b>154,167</b>	<b>-</b>	<b>(154,167)</b>	<b>-100%</b>	<b>370,000</b>	<b>12,839</b>	<b>-</b>	<b>(12,839)</b>	<b>-100%</b>	<b>30,814</b>
<b>YEAR-TO-DATE SURPLUS/(DEFICIT)</b>	<b>(32,792)</b>	<b>102,106</b>	<b>134,898</b>	<b>-411%</b>	<b>(78,700)</b>	<b>(12,464)</b>	<b>1,206</b>	<b>13,670</b>	<b>-110%</b>	<b>(29,914)</b>
	Transportation Impact Fees (64)					Early Warning (65)				
	5 MONTHS ENDED		2024-2025			5 MONTHS ENDED		2024-2025		
	YTD BUDGET	YTD ACTUAL	DELTA \$	DELTA %	TOT BUDGET	YTD BUDGET	YTD ACTUAL	DELTA \$	DELTA %	TOT BUDGET
<b>REVENUE</b>										
Investment Income	-	-	-	0%	-	-	-	-	0%	-
Licenses, Fines, Permits, Fees	119,292	139,060	19,768	17%	286,300	2,795	3,258	463	17%	6,708
Other Income	-	-	-	0%	-	-	-	-	0%	-
Transfers	-	-	-	0%	-	10,417	-	(10,417)	-100%	25,000
<b>TOTAL REVENUE</b>	<b>119,292</b>	<b>139,060</b>	<b>19,768</b>	<b>17%</b>	<b>286,300</b>	<b>13,212</b>	<b>3,258</b>	<b>(9,954)</b>	<b>-75%</b>	<b>31,708</b>
<b>EXPENSE</b>										
Contractual Services	25,000	24,889	(111)	0%	60,000	-	-	-	0%	-
Other Expenses	-	-	-	0%	-	-	-	-	0%	-
Capital Outlay	69,375	159,286	89,911	130%	166,500	12,500	-	(12,500)	-100%	30,000
Transfer to General	-	-	-	0%	-	-	-	-	0%	-
<b>TOTAL EXPENSE</b>	<b>94,375</b>	<b>184,175</b>	<b>89,800</b>	<b>95%</b>	<b>226,500</b>	<b>12,500</b>	<b>-</b>	<b>(12,500)</b>	<b>-100%</b>	<b>30,000</b>
<b>YEAR-TO-DATE SURPLUS/(DEFICIT)</b>	<b>24,917</b>	<b>(45,115)</b>	<b>(70,032)</b>	<b>-281%</b>	<b>59,800</b>	<b>712</b>	<b>3,258</b>	<b>2,546</b>	<b>358%</b>	<b>1,708</b>
	Capital Improvement (70)					Total Capital Project Funds				
	5 MONTHS ENDED		2024-2025			5 MONTHS ENDED		2024-2025		
	YTD BUDGET	YTD ACTUAL	DELTA \$	DELTA %	TOT BUDGET	YTD BUDGET	YTD ACTUAL	DELTA \$	DELTA %	TOT BUDGET
<b>REVENUE</b>										
Investment Income	-	-	-	0%	-	2,479	5,118	2,639	106%	5,950
Licenses, Fines, Permits, Fees	-	-	-	0%	-	599,542	240,663	(358,879)	-60%	1,438,898
Grant Income	-	-	-	0%	-	-	-	-	0%	-
Debt Issuance	-	-	-	0%	-	4,500,000	-	(4,500,000)	-100%	10,800,000
Other Income	-	-	-	0%	-	-	-	-	0%	-
Transfers	-	-	-	0%	-	10,417	-	(10,417)	-100%	25,000
<b>TOTAL REVENUE</b>	<b>-</b>	<b>-</b>	<b>-</b>	<b>0%</b>	<b>-</b>	<b>5,112,438</b>	<b>245,781</b>	<b>(4,866,657)</b>	<b>-95%</b>	<b>12,269,848</b>
<b>EXPENSE</b>										
Contractual Services	-	-	-	0%	-	25,000	24,889	(111)	0%	60,000
Other Expenses	-	-	-	0%	-	366,316	-	(366,316)	-100%	879,159
Capital Outlay	25,379	-	(25,379)	-100%	60,910	4,623,504	159,286	(4,464,218)	-97%	11,096,410
Transfers	-	-	-	0%	-	154,167	-	(154,167)	-100%	370,000
<b>TOTAL EXPENSE</b>	<b>25,379</b>	<b>-</b>	<b>(25,379)</b>	<b>-100%</b>	<b>60,910</b>	<b>5,168,987</b>	<b>184,175</b>	<b>(4,984,812)</b>	<b>-96%</b>	<b>12,405,569</b>
<b>YEAR-TO-DATE SURPLUS/(DEFICIT)</b>	<b>(25,379)</b>	<b>-</b>	<b>25,379</b>	<b>-100%</b>	<b>(60,910)</b>	<b>(56,549)</b>	<b>61,606</b>	<b>118,155</b>	<b>-209%</b>	<b>(135,721)</b>



Village of Hampshire  
 Budget Versus Actual Report - Agency Fund Summary  
 Five Months Ended September 30, 2024

	SSA#14 B&I (43)					SSA#13 B&I (45)				
	5 MONTHS ENDED		2024-2025			5 MONTHS ENDED		2024-2025		
	YTD BUDGET	YTD ACTUAL	DELTA \$	DELTA %	TOT BUDGET	YTD BUDGET	YTD ACTUAL	DELTA \$	DELTA %	TOT BUDGET
<b>REVENUE</b>										
Property Tax	402,574	806,442	403,868	100%	805,149	182,600	357,126	174,526	96%	365,200
Investment Income	12,500	27,146	14,646	117%	30,000	6,250	14,176	7,926	127%	15,000
Licenses, Fines, Permits, Fees	-	-	-	0%	-	-	-	-	0%	-
Other Income	-	-	-	0%	-	-	-	-	0%	-
<b>TOTAL REVENUE</b>	<b>415,074</b>	<b>833,588</b>	<b>418,514</b>	<b>101%</b>	<b>835,149</b>	<b>188,850</b>	<b>371,302</b>	<b>182,452</b>	<b>97%</b>	<b>380,200</b>
<b>EXPENSE</b>										
Other Expenses	351,449	159,239	(192,210)	-55%	843,478	164,989	67,986	(97,003)	-59%	395,973
<b>TOTAL EXPENSE</b>	<b>351,449</b>	<b>159,239</b>	<b>(192,210)</b>	<b>-55%</b>	<b>843,478</b>	<b>164,989</b>	<b>67,986</b>	<b>(97,003)</b>	<b>-59%</b>	<b>395,973</b>
<b>YEAR-TO-DATE SURPLUS/(DEFICIT)</b>	<b>63,625</b>	<b>674,349</b>	<b>610,724</b>	<b>960%</b>	<b>(8,329)</b>	<b>23,861</b>	<b>303,316</b>	<b>279,455</b>	<b>1171%</b>	<b>(15,773)</b>

	Total Agency Funds				
	5 MONTHS ENDED		2024-2025		
	YTD BUDGET	YTD ACTUAL	DELTA \$	DELTA %	TOT BUDGET
<b>REVENUE</b>					
Property Tax	585,174	1,163,568	578,394	99%	1,170,349
Investment Income	18,750	41,322	22,572	120%	45,000
Licenses, Fines, Permits, Fees	-	-	-	0%	-
<b>TOTAL REVENUE</b>	<b>603,924</b>	<b>1,204,890</b>	<b>600,966</b>	<b>100%</b>	<b>1,215,349</b>
<b>EXPENSE</b>					
Other Expenses	516,438	227,225	(289,213)	-56%	1,239,451
<b>TOTAL EXPENSE</b>	<b>516,438</b>	<b>227,225</b>	<b>(289,213)</b>	<b>-56%</b>	<b>1,239,451</b>
<b>YEAR-TO-DATE SURPLUS/(DEFICIT)</b>	<b>87,486</b>	<b>977,665</b>	<b>890,179</b>	<b>1018%</b>	<b>(24,102)</b>

Village of Hampshire  
 Budget Versus Actual Report - Pension Trust Summary  
 Five Months Ended September 30, 2024

	<b>Pension Trust Fund Revenues (90)</b>				
	<b>5 MONTHS ENDED</b>				<b>2024-2025</b>
	<b>YTD BUDGET</b>	<b>YTD ACTUAL</b>	<b>DELTA \$</b>	<b>DELTA %</b>	<b>TOT BUDGET</b>
<b>REVENUE</b>					
Investment Income	104,167	18,619	(85,548)	-82%	250,000
Realized and Unrealized Gain/(Loss)	-	364,786	364,786	100%	-
Less: Investment Fees	-	(982)	(982)	-100%	-
Member Contributions	40,715	44,251	3,536	9%	97,717
Employer Contributions	239,583	-	(239,583)	-100%	575,000
Creditable Service Transfer In	-	-	-	0%	-
Miscellaneous Income	-	-	-	0%	-
<b>TOTAL REVENUE</b>	<b>384,465</b>	<b>426,674</b>	<b>42,209</b>	<b>11%</b>	<b>922,717</b>

	<b>Pension Trust Fund Expenses (90)</b>				
	<b>5 MONTHS ENDED</b>				<b>2024-2025</b>
	<b>YTD BUDGET</b>	<b>YTD ACTUAL</b>	<b>DELTA \$</b>	<b>DELTA %</b>	<b>TOT BUDGET</b>
<b>EXPENSE</b>					
Pension Payments	88,022	81,219	(6,803)	-8%	211,253
Refund of Contributions	125,246	-	(125,246)	-100%	300,591
Transfer to Other Pension Funds	-	-	-	0%	-
Contractual Services	21,458	3,162	(18,296)	-85%	51,500
Other Expenses	1,125	825	(300)	-27%	2,700
<b>TOTAL EXPENSE</b>	<b>235,851</b>	<b>85,206</b>	<b>(150,645)</b>	<b>-64%</b>	<b>566,044</b>
<b>YEAR-TO-DATE SURPLUS/(DEFICIT)</b>	<b>148,614</b>	<b>341,468</b>	<b>192,854</b>	<b>130%</b>	<b>356,673</b>